

Cambridge Waste Water Treatment Plant Relocation Project
Anglian Water Services Limited

Appendix 19.6: Junction Capacity Reports

Application Document Reference: 5.4.19.6
PINS Project Reference: WW010003
APFP Regulation No. 5(2)a

Revision No. 03
March 2024

Document Control

Document title	Appendix 5.4.19.6 Junction Capacity Reports
Version No.	03
Date Approved	26.03.24
Date 1st Issued	29.09.23

Version History

Version	Date	Author	Description of change
01	30.01.23	-	DCO Submission
02	08.03.24	-	Additional submission Feb 2024
03	26.03.24	-	Update following ISH4 – Addition contents, version control details / updated model output sheets

This document is issued for the party which commissioned it and for specific purposes connected with the above-captioned project only. It should not be relied upon by any other party or used for any other purpose.

We accept no responsibility for the consequences of this document being relied upon by any other party, or being used for any other purpose, or containing any error or omission which is due to an error or omission in data supplied to us by other parties

This document contains confidential information and proprietary intellectual property. It should not be shown to other parties without consent from us and from the party which commissioned it

Contents

1	Horningsea Road / Junction 34 of the A14 (existing junction Layout) (LinSig)	1
2	Horningsea Road / Junction 34 of the A14 (proposed lay-out) (LinSig)	23
3	A10 / Denny End Road (LinSig)	49
4	A10 / Car Dyke Road (Junctions 9)	62
5	Junction 33 - Milton Interchange (LinSig)	81
6	Milton Road / Cowley Road (LinSig)	137
7	Milton Road / Green End Road / Kings Hedges (LinSig)	159
8	Water Lane / High Street / Green End Road (Junctions 9)	178

1 Horningsea Road / Junction 34 of the A14 (existing junction Layout)

- 2021 Baseline AM
- 2021 Baseline PM
- Construction Year 3 (2026) – Future Baseline AM
- Construction Year 3 (2026) – Future Baseline PM
- Construction Year 5 (2028) – Future Baseline AM
- Construction Year 5 (2028) – Future Baseline PM
- Operation Year 1 + 5 (2033) – Future Baseline AM
- Operation Year 1 + 5 (2033) – Future Baseline PM
- Operation Year 1 + 10 (2038) – Future Baseline AM
- Operation Year 1 + 10 (2038) – Future Baseline PM

Basic Results Summary
Basic Results Summary

User and Project Details

Project:	100102041 – AWS Cambridge WWTPRP
Title:	A14 Junction 34
Location:	
Client:	Anglian Water
Date Completed:	07.02.24
Model Purpose:	Existing Layout
Model Assumptions:	
Flow Details:	https://mottmac.sharepoint.com/:x:/r/teams/pj-d2780/do/Develop/06%20-%20Technical%20Disciplines/12%20-%20Transport/03%20Technical%20Analysis/Traffic%20Flow%20Diagrams/Version%202%20-%20January%202024/Cambridge%20WWTP_Traffic%20Flow%20Diagrams.xlsx?d=w4f367f2dfb614195b49eeda3869d06c&csf=1&web=1&e=cAWS2S
Checked By:	TE
Additional detail:	
File name:	Jun 34 Fen Ditton Junction with Bonus Green.lsg3x
Author:	ZB
Company:	Mott MacDonald
Address:	

Scenario 1: '2021 Base AM' (FG1: '2021 Base AM', Plan 1: 'Network Control Plan 1')

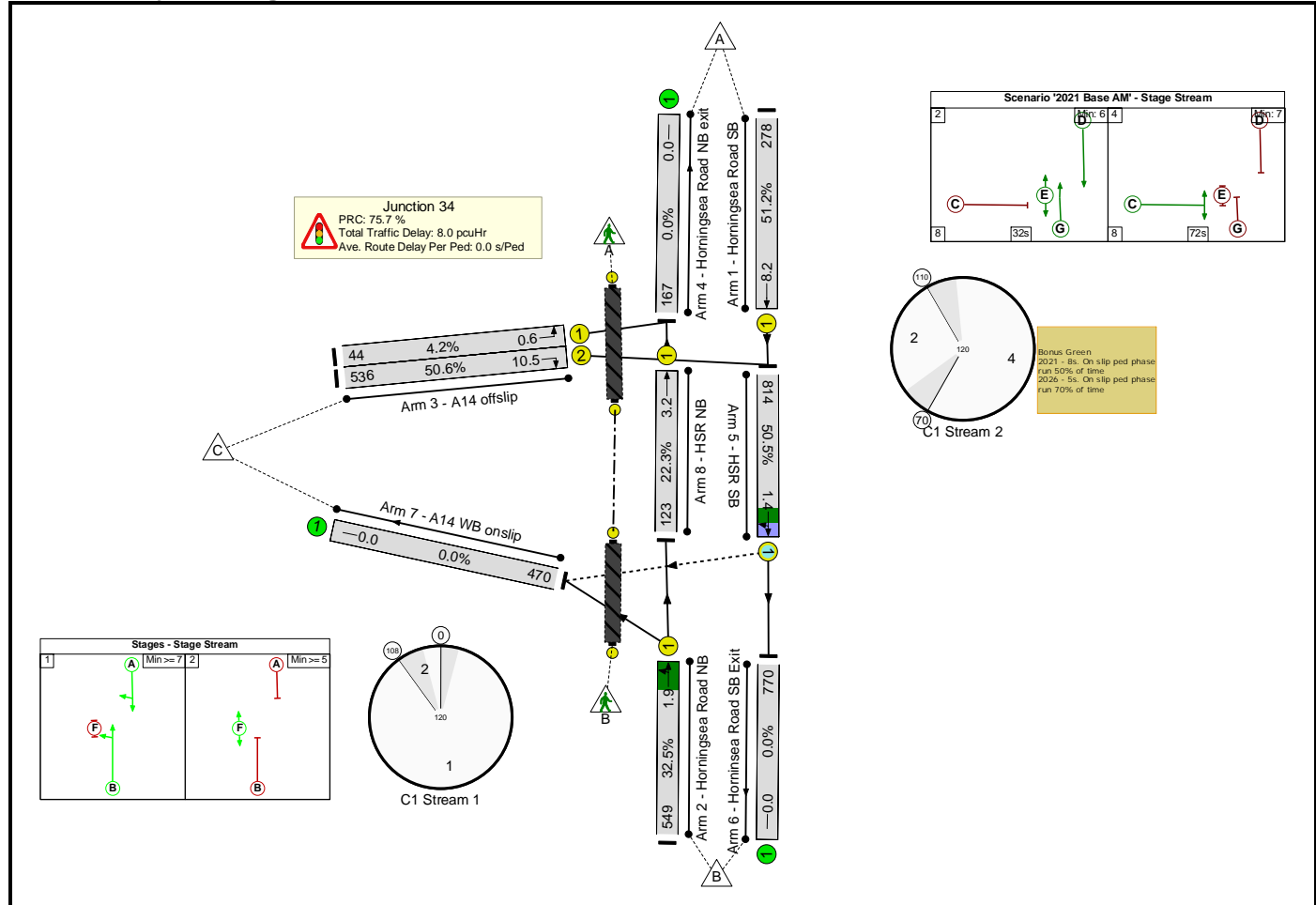

Basic Results Summary

Network Results

Item	Lane Description	Lane Type	Full Phase	Arrow Phase	Num Greens	Total Green (s)	Arrow Green (s)	Demand Flow (pcu)	Sat Flow (pcu/Hr)	Capacity (pcu)	Deg Sat (%)	Turners In Gaps (pcu)	Turners When Unopposed (pcu)	Turners In Intergreen (pcu)	Total Delay (pcuHr)	Av. Delay Per PCU (s/pcu)	Mean Max Queue (pcu)
Network	-	-	-		-	-	-	-	-	-	51.2%	43	1	0	8.0	-	-
Junction 34	-	-	-		-	-	-	-	-	-	51.2%	43	1	0	8.0	-	-
1/1	Horningsea Road SB Ahead	U	D		1	33	-	278	1915	543	51.2%	-	-	-	3.3	42.8	8.2
2/1	Horningsea Road NB Left Ahead	U	B		1	103	-	549	1811	1690	32.5%	-	-	-	0.3	2.0	1.9
3/1	A14 offslip Left	U	C		1	72	-	44	1712	1041	4.2%	-	-	-	0.1	11.3	0.6
3/2	A14 offslip Right	U	C		1	72	-	536	1742	1060	50.6%	-	-	-	2.5	16.7	10.5
5/1	HSR SB Ahead Right	O	A		1	103	-	814	1902	1613	50.5%	43	1	0	0.6	2.6	1.4
8/1	HSR NB Ahead	U	G		1	34	-	123	1895	553	22.3%	-	-	-	1.2	36.0	3.2
Ped Link: P1	Offslip crossing	-	E		1	32	-	0	-	19200	0.0%	-	-	-	0.0	0.0	0.0
Ped Link: P2	Onslip crossing	-	F		1	5	-	0	-	3000	0.0%	-	-	-	0.0	0.0	0.0
							C1 Stream: 1 PRC for Signalled Lanes (%):	78.3	Total Delay for Signalled Lanes (pcuHr):			0.88	Cycle Time (s): 120				
							C1 Stream: 2 PRC for Signalled Lanes (%):	75.7	Total Delay for Signalled Lanes (pcuHr):			7.17	Cycle Time (s): 120				
							PRC Over All Lanes (%):	75.7	Total Delay Over All Lanes(pcuHr):			8.04					

Basic Results Summary

Scenario 2: '2021 Base PM' (FG2: '2021 Base PM', Plan 1: 'Network Control Plan 1')

Network Layout Diagram

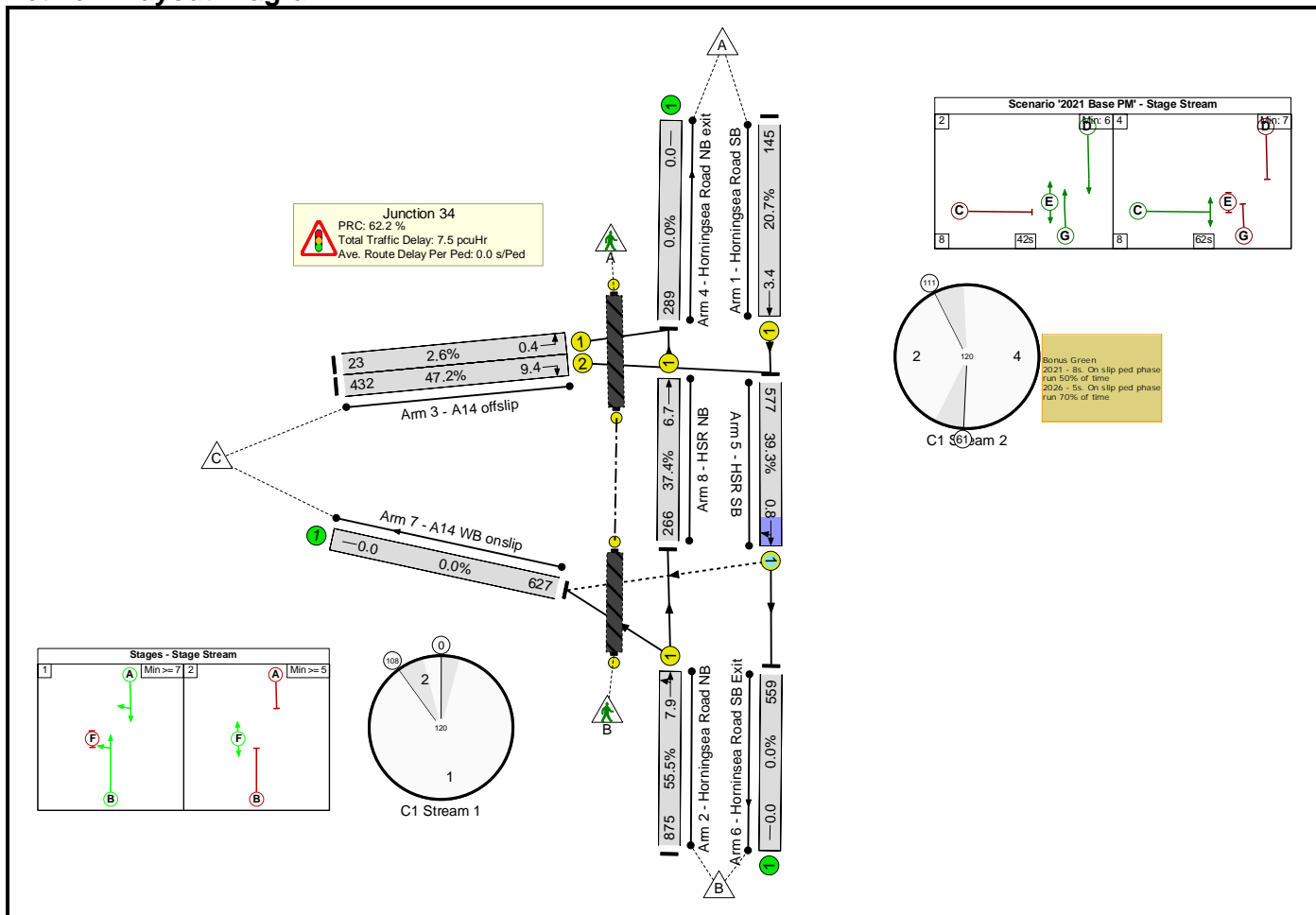

Basic Results Summary

Network Results

Item	Lane Description	Lane Type	Full Phase	Arrow Phase	Num Greens	Total Green (s)	Arrow Green (s)	Demand Flow (pcu)	Sat Flow (pcu/Hr)	Capacity (pcu)	Deg Sat (%)	Turners In Gaps (pcu)	Turners When Unopposed (pcu)	Turners In Intergreen (pcu)	Total Delay (pcuHr)	Av. Delay Per PCU (s/pcu)	Mean Max Queue (pcu)	
Network	-	-	-		-	-	-	-	-	-	55.5%	16	2	0	7.5	-	-	
Junction 34	-	-	-		-	-	-	-	-	-	55.5%	16	2	0	7.5	-	-	
1/1	Horningsea Road SB Ahead	U	D		1	43	-	145	1915	702	20.7%	-	-	-	1.2	29.3	3.4	
2/1	Horningsea Road NB Left Ahead	U	B		1	103	-	875	1819	1576	55.5%	-	-	-	1.1	4.6	7.9	
3/1	A14 offslip Left	U	C		1	62	-	23	1712	899	2.6%	-	-	-	0.1	15.8	0.4	
3/2	A14 offslip Right	U	C		1	62	-	432	1742	915	47.2%	-	-	-	2.6	21.7	9.4	
5/1	HSR SB Ahead Right	O	A		1	103	-	577	1908	1468	39.3%	16	2	0	0.4	2.3	0.8	
8/1	HSR NB Ahead	U	G		1	44	-	266	1895	711	37.4%	-	-	-	2.2	29.3	6.7	
Ped Link: P1	Offslip crossing	-	E		1	42	-	0	-	25200	0.0%	-	-	-	0.0	0.0	0.0	
Ped Link: P2	Onslip crossing	-	F		1	5	-	0	-	3000	0.0%	-	-	-	0.0	0.0	0.0	
							C1 Stream: 1 PRC for Signalled Lanes (%):	62.2	Total Delay for Signalled Lanes (pcuHr):			1.49	Cycle Time (s):		120			
							C1 Stream: 2 PRC for Signalled Lanes (%):	90.5	Total Delay for Signalled Lanes (pcuHr):			6.05	Cycle Time (s):		120			
							PRC Over All Lanes (%):	62.2	Total Delay Over All Lanes(pcuHr):			7.54						

Basic Results Summary

Scenario 3: '2026 Base AM' (FG3: '2026 Base AM', Plan 1: 'Network Control Plan 1')

Network Layout Diagram

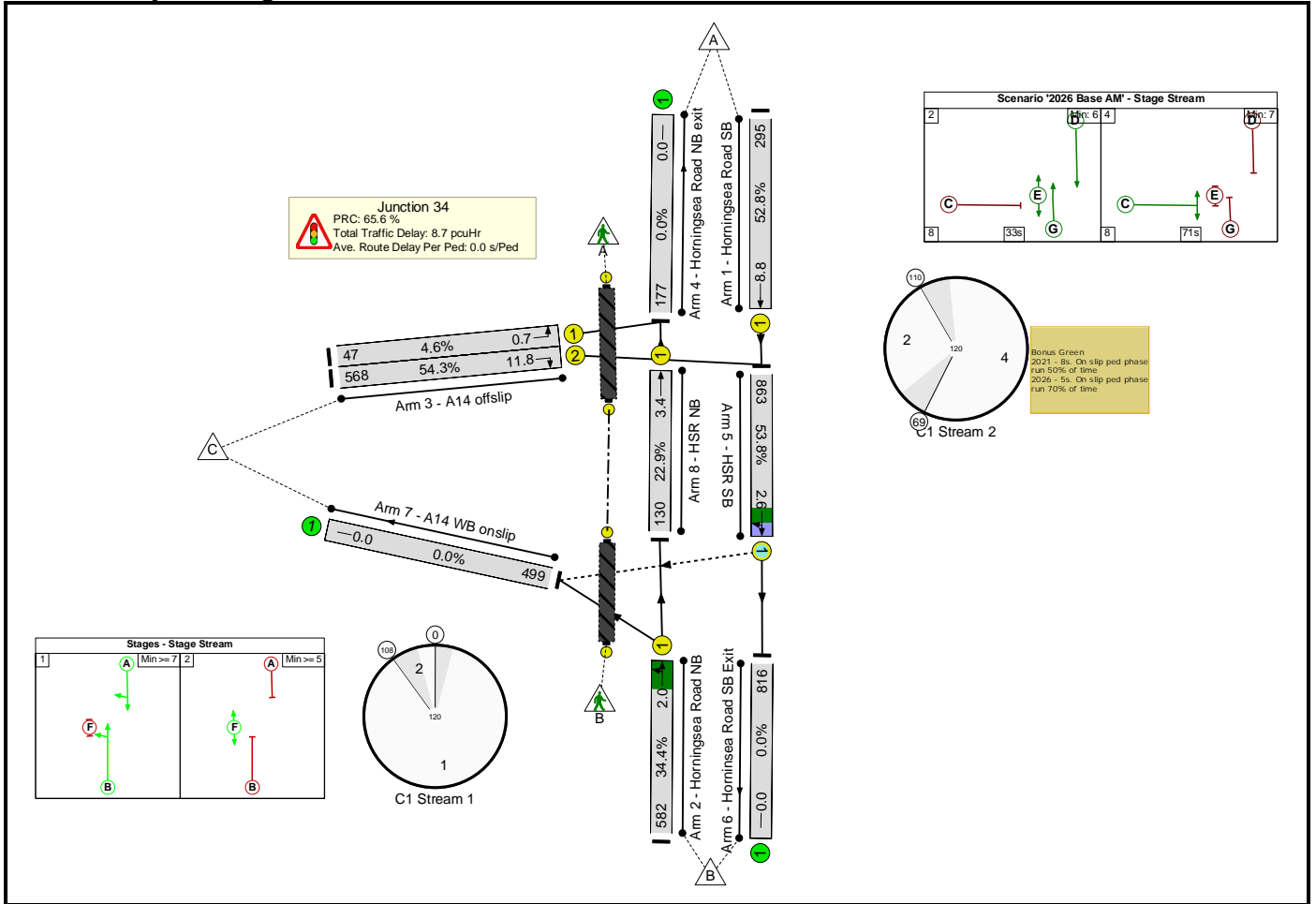

Basic Results Summary

Network Results

Item	Lane Description	Lane Type	Full Phase	Arrow Phase	Num Greens	Total Green (s)	Arrow Green (s)	Demand Flow (pcu)	Sat Flow (pcu/Hr)	Capacity (pcu)	Deg Sat (%)	Turners In Gaps (pcu)	Turners When Unopposed (pcu)	Turners In Intergreen (pcu)	Total Delay (pcuHr)	Av. Delay Per PCU (s/pcu)	Mean Max Queue (pcu)	
Network	-	-	-		-	-	-	-	-	-	54.3%	46	1	0	8.7	-	-	
Junction 34	-	-	-		-	-	-	-	-	-	54.3%	46	1	0	8.7	-	-	
1/1	Horningsea Road SB Ahead	U	D		1	34	-	295	1915	559	52.8%	-	-	-	3.5	42.4	8.8	
2/1	Horningsea Road NB Left Ahead	U	B		1	103	-	582	1811	1690	34.4%	-	-	-	0.3	2.0	2.0	
3/1	A14 offslip Left	U	C		1	71	-	47	1712	1027	4.6%	-	-	-	0.2	11.7	0.7	
3/2	A14 offslip Right	U	C		1	71	-	568	1742	1045	54.3%	-	-	-	2.8	18.0	11.8	
5/1	HSR SB Ahead Right	O	A		1	103	-	863	1902	1605	53.8%	46	1	0	0.7	2.8	2.6	
8/1	HSR NB Ahead	U	G		1	35	-	130	1895	569	22.9%	-	-	-	1.3	35.3	3.4	
Ped Link: P1	Offslip crossing	-	E		1	33	-	0	-	19800	0.0%	-	-	-	0.0	0.0	0.0	
Ped Link: P2	Onslip crossing	-	F		1	5	-	0	-	3000	0.0%	-	-	-	0.0	0.0	0.0	
							C1 Stream: 1 PRC for Signalled Lanes (%):	67.4	Total Delay for Signalled Lanes (pcuHr):			0.99	Cycle Time (s):		120			
							C1 Stream: 2 PRC for Signalled Lanes (%):	65.6	Total Delay for Signalled Lanes (pcuHr):			7.74	Cycle Time (s):		120			
							PRC Over All Lanes (%):	65.6	Total Delay Over All Lanes(pcuHr):			8.73						

Basic Results Summary

Scenario 4: '2026 Base PM' (FG4: '2026 Base PM', Plan 1: 'Network Control Plan 1')

Network Layout Diagram

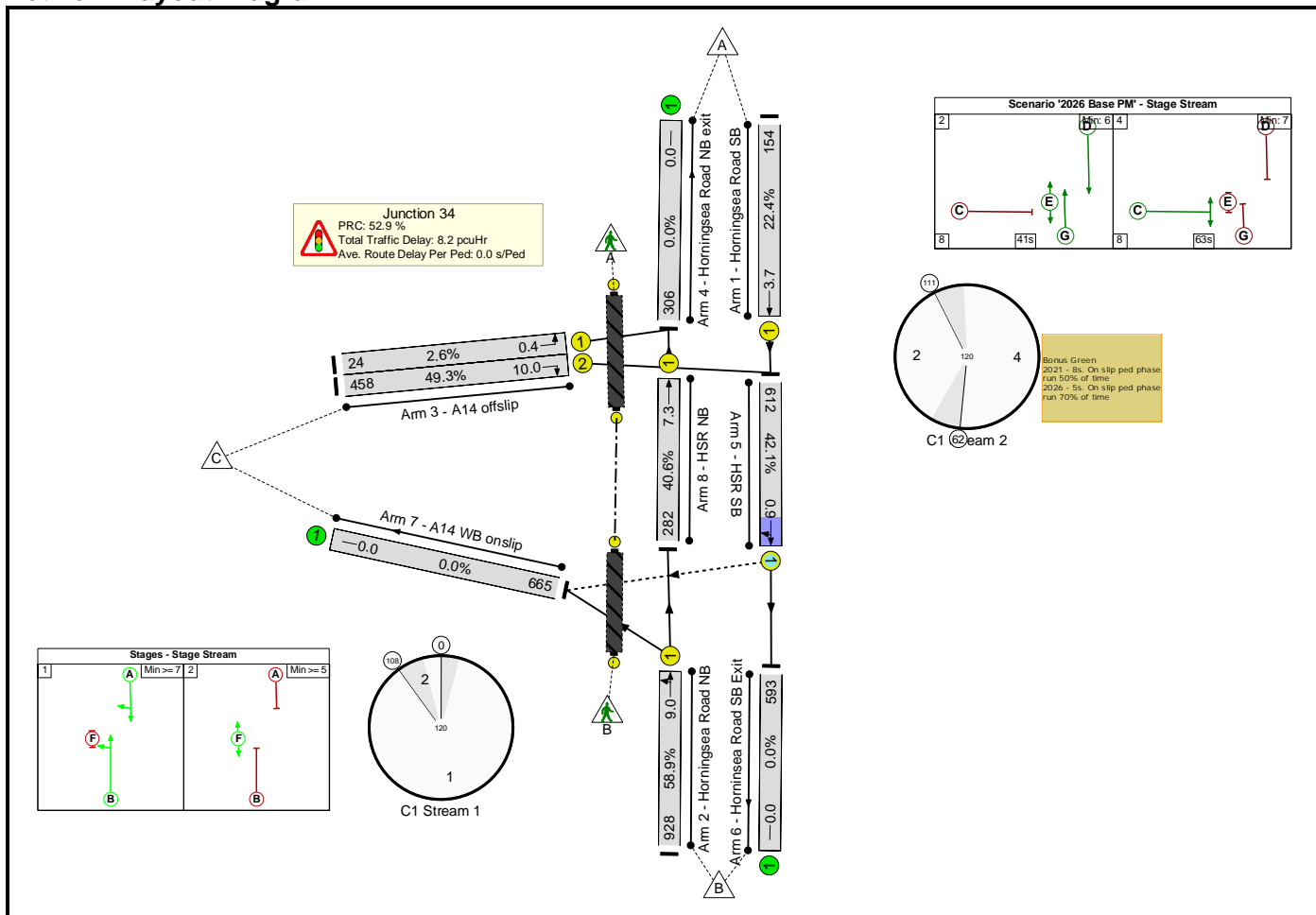

Basic Results Summary

Network Results

Item	Lane Description	Lane Type	Full Phase	Arrow Phase	Num Greens	Total Green (s)	Arrow Green (s)	Demand Flow (pcu)	Sat Flow (pcu/Hr)	Capacity (pcu)	Deg Sat (%)	Turners In Gaps (pcu)	Turners When Unopposed (pcu)	Turners In Intergreen (pcu)	Total Delay (pcuHr)	Av. Delay Per PCU (s/pcu)	Mean Max Queue (pcu)	
Network	-	-	-		-	-	-	-	-	-	58.9%	17	2	0	8.2	-	-	
Junction 34	-	-	-		-	-	-	-	-	-	58.9%	17	2	0	8.2	-	-	
1/1	Horningsea Road SB Ahead	U	D		1	42	-	154	1915	686	22.4%	-	-	-	1.3	30.3	3.7	
2/1	Horningsea Road NB Left Ahead	U	B		1	103	-	928	1819	1576	58.9%	-	-	-	1.3	4.9	9.0	
3/1	A14 offslip Left	U	C		1	63	-	24	1712	913	2.6%	-	-	-	0.1	15.3	0.4	
3/2	A14 offslip Right	U	C		1	63	-	458	1742	929	49.3%	-	-	-	2.7	21.5	10.0	
5/1	HSR SB Ahead Right	O	A		1	103	-	612	1908	1453	42.1%	17	2	0	0.4	2.4	0.9	
8/1	HSR NB Ahead	U	G		1	43	-	282	1895	695	40.6%	-	-	-	2.4	30.5	7.3	
Ped Link: P1	Offslip crossing	-	E		1	41	-	0	-	24600	0.0%	-	-	-	0.0	0.0	0.0	
Ped Link: P2	Onslip crossing	-	F		1	5	-	0	-	3000	0.0%	-	-	-	0.0	0.0	0.0	
							C1 Stream: 1 PRC for Signalled Lanes (%):	52.9	Total Delay for Signalled Lanes (pcuHr):			1.69	Cycle Time (s):		120			
							C1 Stream: 2 PRC for Signalled Lanes (%):	82.6	Total Delay for Signalled Lanes (pcuHr):			6.52	Cycle Time (s):		120			
							PRC Over All Lanes (%):	52.9	Total Delay Over All Lanes(pcuHr):			8.21						

Basic Results Summary

Scenario 5: '2028 Base AM' (FG5: '2028 Base AM', Plan 1: 'Network Control Plan 1')

Network Layout Diagram

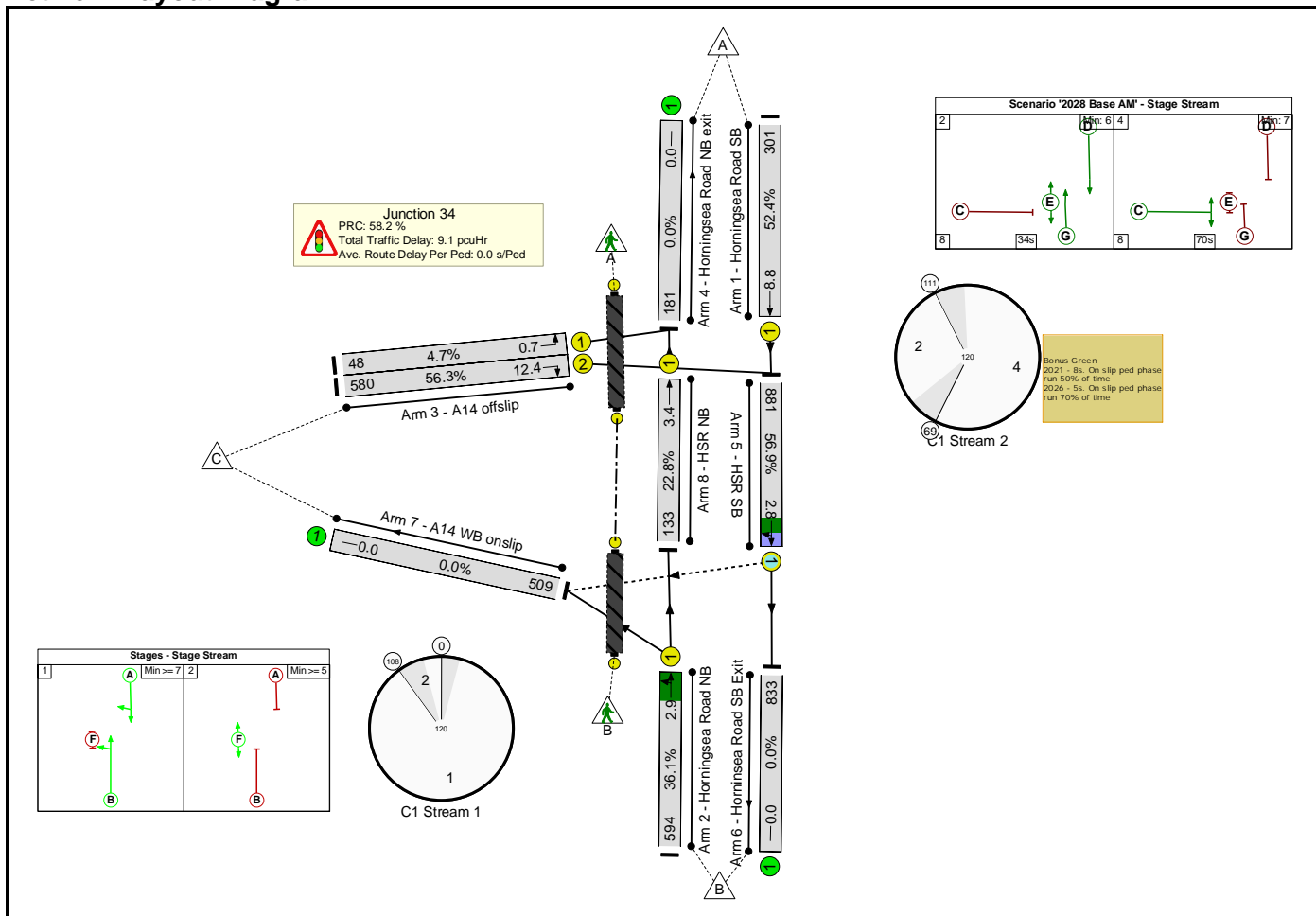

Basic Results Summary

Network Results

Item	Lane Description	Lane Type	Full Phase	Arrow Phase	Num Greens	Total Green (s)	Arrow Green (s)	Demand Flow (pcu)	Sat Flow (pcu/Hr)	Capacity (pcu)	Deg Sat (%)	Turners In Gaps (pcu)	Turners When Unopposed (pcu)	Turners In Intergreen (pcu)	Total Delay (pcuHr)	Av. Delay Per PCU (s/pcu)	Mean Max Queue (pcu)
Network	-	-	-		-	-	-	-	-	-	56.9%	45	3	0	9.1	-	-
Junction 34	-	-	-		-	-	-	-	-	-	56.9%	45	3	0	9.1	-	-
1/1	Horningsea Road SB Ahead	U	D		1	35	-	301	1915	574	52.4%	-	-	-	3.5	41.4	8.8
2/1	Horningsea Road NB Left Ahead	U	B		1	103	-	594	1811	1645	36.1%	-	-	-	0.4	2.5	2.9
3/1	A14 offslip Left	U	C		1	70	-	48	1712	1013	4.7%	-	-	-	0.2	12.2	0.7
3/2	A14 offslip Right	U	C		1	70	-	580	1742	1031	56.3%	-	-	-	3.1	19.0	12.4
5/1	HSR SB Ahead Right	O	A		1	103	-	881	1902	1549	56.9%	45	3	0	0.8	3.2	2.8
8/1	HSR NB Ahead	U	G		1	36	-	133	1895	584	22.8%	-	-	-	1.3	34.1	3.4
Ped Link: P1	Offslip crossing	-	E		1	34	-	0	-	20400	0.0%	-	-	-	0.0	0.0	0.0
Ped Link: P2	Onslip crossing	-	F		1	5	-	0	-	3000	0.0%	-	-	-	0.0	0.0	0.0
							C1 Stream: 1 PRC for Signalled Lanes (%):	58.2	Total Delay for Signalled Lanes (pcuHr):			1.18	Cycle Time (s): 120				
							C1 Stream: 2 PRC for Signalled Lanes (%):	59.9	Total Delay for Signalled Lanes (pcuHr):			7.95	Cycle Time (s): 120				
							PRC Over All Lanes (%):	58.2	Total Delay Over All Lanes(pcuHr):			9.13					

Basic Results Summary

Scenario 6: '2028 Base PM' (FG6: '2028 Base PM', Plan 1: 'Network Control Plan 1')

Network Layout Diagram

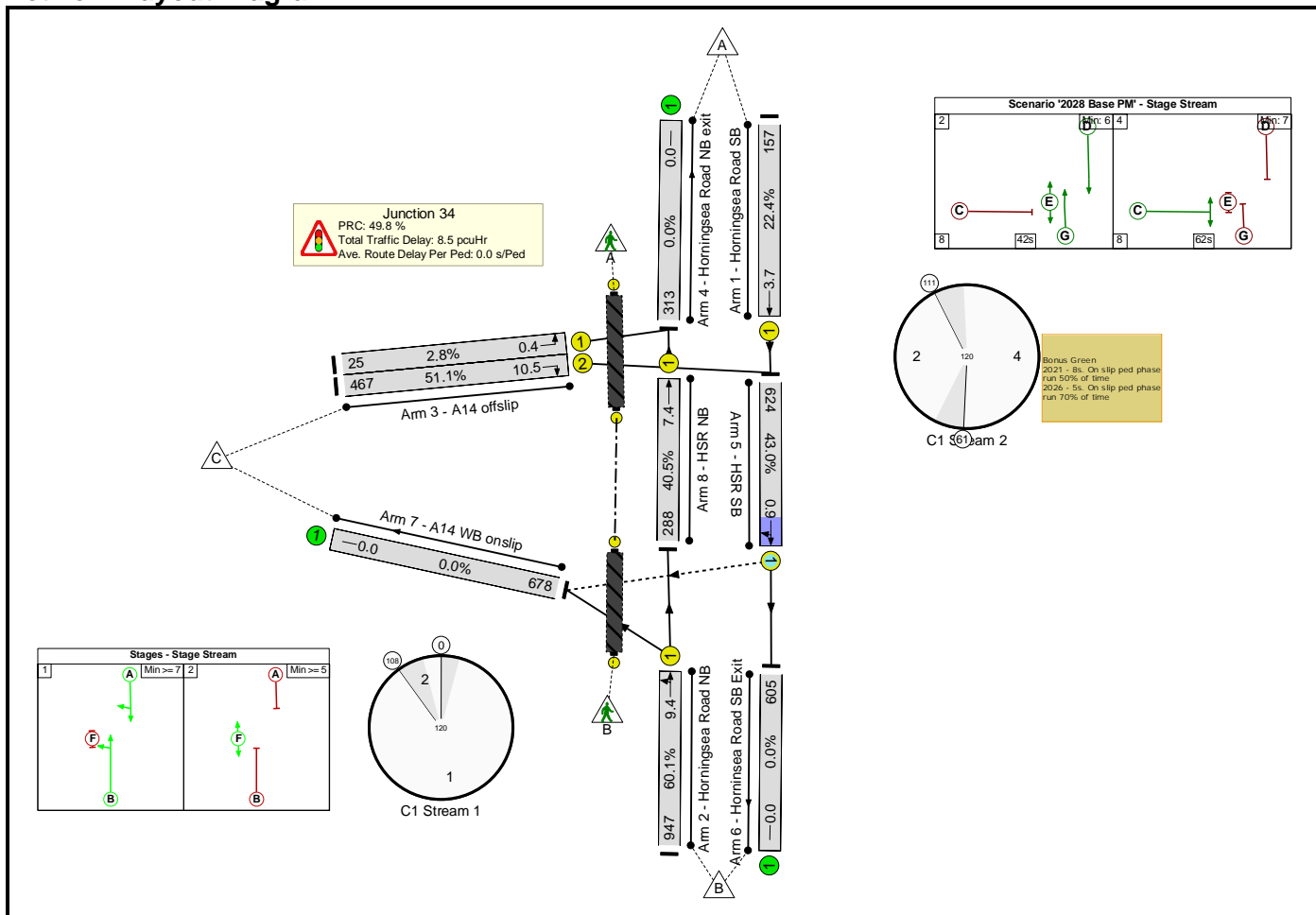

Basic Results Summary

Network Results

Item	Lane Description	Lane Type	Full Phase	Arrow Phase	Num Greens	Total Green (s)	Arrow Green (s)	Demand Flow (pcu)	Sat Flow (pcu/Hr)	Capacity (pcu)	Deg Sat (%)	Turners In Gaps (pcu)	Turners When Unopposed (pcu)	Turners In Intergreen (pcu)	Total Delay (pcuHr)	Av. Delay Per PCU (s/pcu)	Mean Max Queue (pcu)	
Network	-	-	-		-	-	-	-	-	-	60.1%	17	2	0	8.5	-	-	
Junction 34	-	-	-		-	-	-	-	-	-	60.1%	17	2	0	8.5	-	-	
1/1	Horningsea Road SB Ahead	U	D		1	43	-	157	1915	702	22.4%	-	-	-	1.3	29.5	3.7	
2/1	Horningsea Road NB Left Ahead	U	B		1	103	-	947	1819	1576	60.1%	-	-	-	1.3	5.1	9.4	
3/1	A14 offslip Left	U	C		1	62	-	25	1712	899	2.8%	-	-	-	0.1	15.8	0.4	
3/2	A14 offslip Right	U	C		1	62	-	467	1742	915	51.1%	-	-	-	2.9	22.5	10.5	
5/1	HSR SB Ahead Right	O	A		1	103	-	624	1908	1450	43.0%	17	2	0	0.4	2.5	0.9	
8/1	HSR NB Ahead	U	G		1	44	-	288	1895	711	40.5%	-	-	-	2.4	29.7	7.4	
Ped Link: P1	Offslip crossing	-	E		1	42	-	0	-	25200	0.0%	-	-	-	0.0	0.0	0.0	
Ped Link: P2	Onslip crossing	-	F		1	5	-	0	-	3000	0.0%	-	-	-	0.0	0.0	0.0	
							C1 Stream: 1 PRC for Signalled Lanes (%):	49.8	Total Delay for Signalled Lanes (pcuHr):			1.76	Cycle Time (s):		120			
							C1 Stream: 2 PRC for Signalled Lanes (%):	76.3	Total Delay for Signalled Lanes (pcuHr):			6.69	Cycle Time (s):		120			
							PRC Over All Lanes (%):	49.8	Total Delay Over All Lanes(pcuHr):			8.45						

Basic Results Summary

Scenario 7: '2033 Base AM' (FG7: '2033 Base AM', Plan 1: 'Network Control Plan 1')

Network Layout Diagram

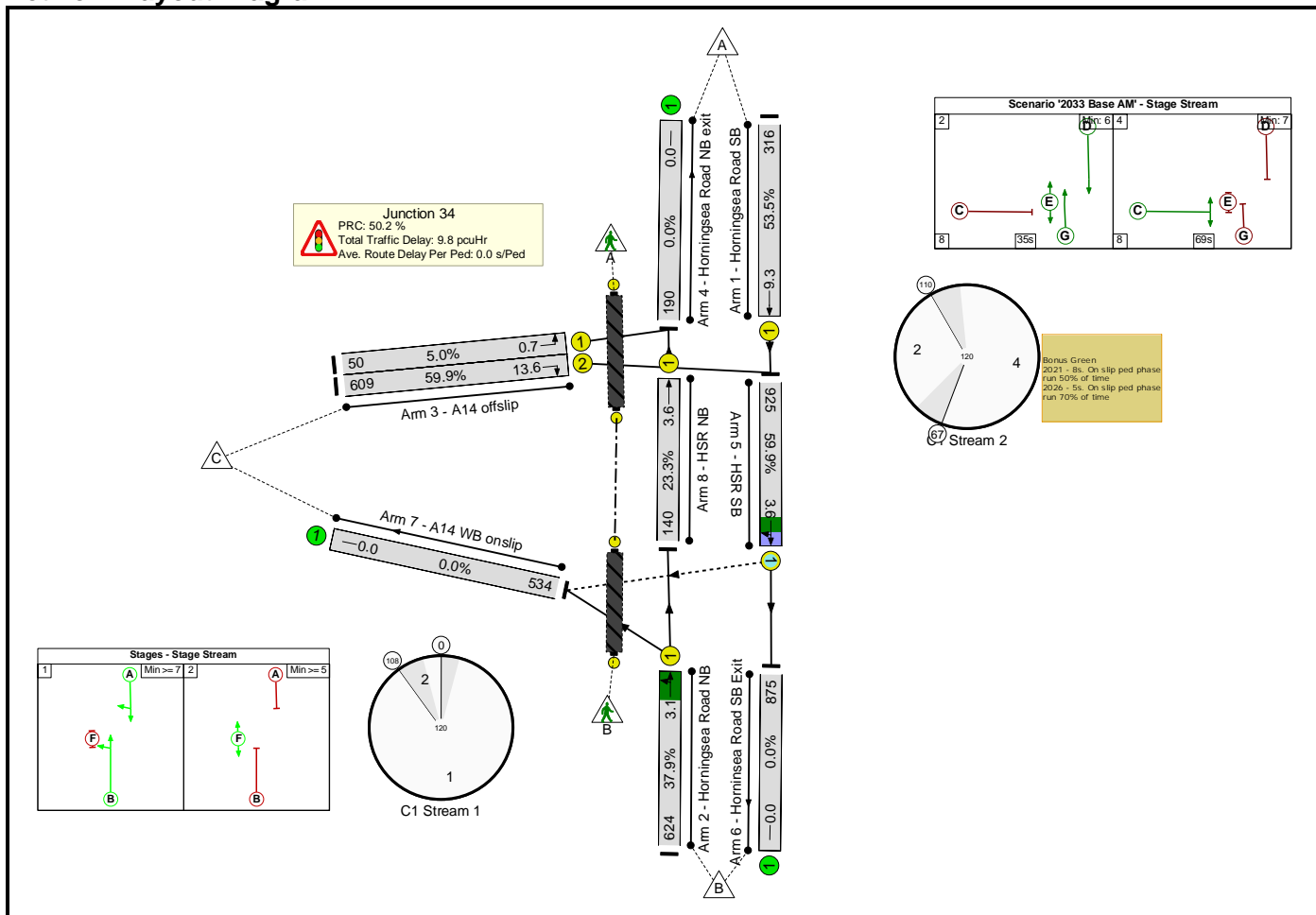

Basic Results Summary

Network Results

Item	Lane Description	Lane Type	Full Phase	Arrow Phase	Num Greens	Total Green (s)	Arrow Green (s)	Demand Flow (pcu)	Sat Flow (pcu/Hr)	Capacity (pcu)	Deg Sat (%)	Turners In Gaps (pcu)	Turners When Unopposed (pcu)	Turners In Intergreen (pcu)	Total Delay (pcuHr)	Av. Delay Per PCU (s/pcu)	Mean Max Queue (pcu)
Network	-	-	-		-	-	-	-	-	-	59.9%	47	3	0	9.8	-	-
Junction 34	-	-	-		-	-	-	-	-	-	59.9%	47	3	0	9.8	-	-
1/1	Horningsea Road SB Ahead	U	D		1	36	-	316	1915	590	53.5%	-	-	-	3.6	40.9	9.3
2/1	Horningsea Road NB Left Ahead	U	B		1	103	-	624	1811	1645	37.9%	-	-	-	0.4	2.5	3.1
3/1	A14 offslip Left	U	C		1	69	-	50	1712	999	5.0%	-	-	-	0.2	12.7	0.7
3/2	A14 offslip Right	U	C		1	69	-	609	1742	1016	59.9%	-	-	-	3.5	20.4	13.6
5/1	HSR SB Ahead Right	O	A		1	103	-	925	1902	1543	59.9%	47	3	0	0.9	3.4	3.6
8/1	HSR NB Ahead	U	G		1	37	-	140	1895	600	23.3%	-	-	-	1.3	33.4	3.6
Ped Link: P1	Offslip crossing	-	E		1	35	-	0	-	21000	0.0%	-	-	-	0.0	0.0	0.0
Ped Link: P2	Onslip crossing	-	F		1	5	-	0	-	3000	0.0%	-	-	-	0.0	0.0	0.0
							C1 Stream: 1 PRC for Signalled Lanes (%):	50.2	Total Delay for Signalled Lanes (pcuHr):			1.31	Cycle Time (s): 120				
							C1 Stream: 2 PRC for Signalled Lanes (%):	50.2	Total Delay for Signalled Lanes (pcuHr):			8.52	Cycle Time (s): 120				
							PRC Over All Lanes (%):	50.2	Total Delay Over All Lanes(pcuHr):			9.84					

Basic Results Summary

Scenario 8: '2033 Base PM' (FG8: '2033 Base PM', Plan 1: 'Network Control Plan 1')

Network Layout Diagram

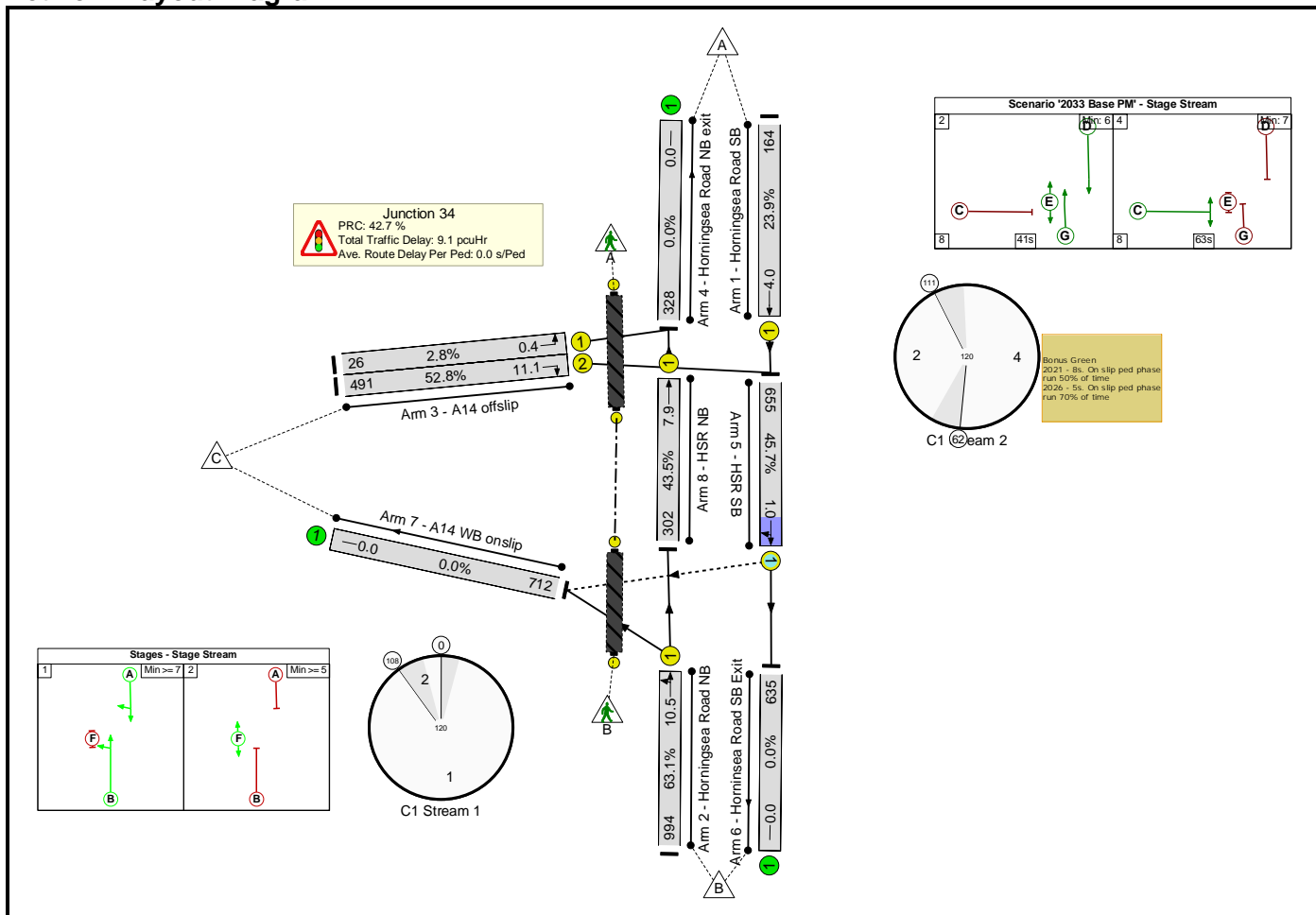

Basic Results Summary

Network Results

Item	Lane Description	Lane Type	Full Phase	Arrow Phase	Num Greens	Total Green (s)	Arrow Green (s)	Demand Flow (pcu)	Sat Flow (pcu/Hr)	Capacity (pcu)	Deg Sat (%)	Turners In Gaps (pcu)	Turners When Unopposed (pcu)	Turners In Intergreen (pcu)	Total Delay (pcuHr)	Av. Delay Per PCU (s/pcu)	Mean Max Queue (pcu)
Network	-	-	-		-	-	-	-	-	-	63.1%	18	2	0	9.1	-	-
Junction 34	-	-	-		-	-	-	-	-	-	63.1%	18	2	0	9.1	-	-
1/1	Horningsea Road SB Ahead	U	D		1	42	-	164	1915	686	23.9%	-	-	-	1.4	30.5	4.0
2/1	Horningsea Road NB Left Ahead	U	B		1	103	-	994	1819	1576	63.1%	-	-	-	1.5	5.4	10.5
3/1	A14 offslip Left	U	C		1	63	-	26	1712	913	2.8%	-	-	-	0.1	15.3	0.4
3/2	A14 offslip Right	U	C		1	63	-	491	1742	929	52.8%	-	-	-	3.0	22.3	11.1
5/1	HSR SB Ahead Right	O	A		1	103	-	655	1908	1434	45.7%	18	2	0	0.5	2.6	1.0
8/1	HSR NB Ahead	U	G		1	43	-	302	1895	695	43.5%	-	-	-	2.6	30.9	7.9
Ped Link: P1	Offslip crossing	-	E		1	41	-	0	-	24600	0.0%	-	-	-	0.0	0.0	0.0
Ped Link: P2	Onslip crossing	-	F		1	5	-	0	-	3000	0.0%	-	-	-	0.0	0.0	0.0
							C1 Stream: 1 PRC for Signalled Lanes (%):	42.7	Total Delay for Signalled Lanes (pcuHr):			1.97	Cycle Time (s): 120				
							C1 Stream: 2 PRC for Signalled Lanes (%):	70.3	Total Delay for Signalled Lanes (pcuHr):			7.13	Cycle Time (s): 120				
							PRC Over All Lanes (%):	42.7	Total Delay Over All Lanes(pcuHr):			9.10					

Basic Results Summary

Scenario 9: '2038 Base AM' (FG9: '2038 Base AM', Plan 1: 'Network Control Plan 1')

Network Layout Diagram

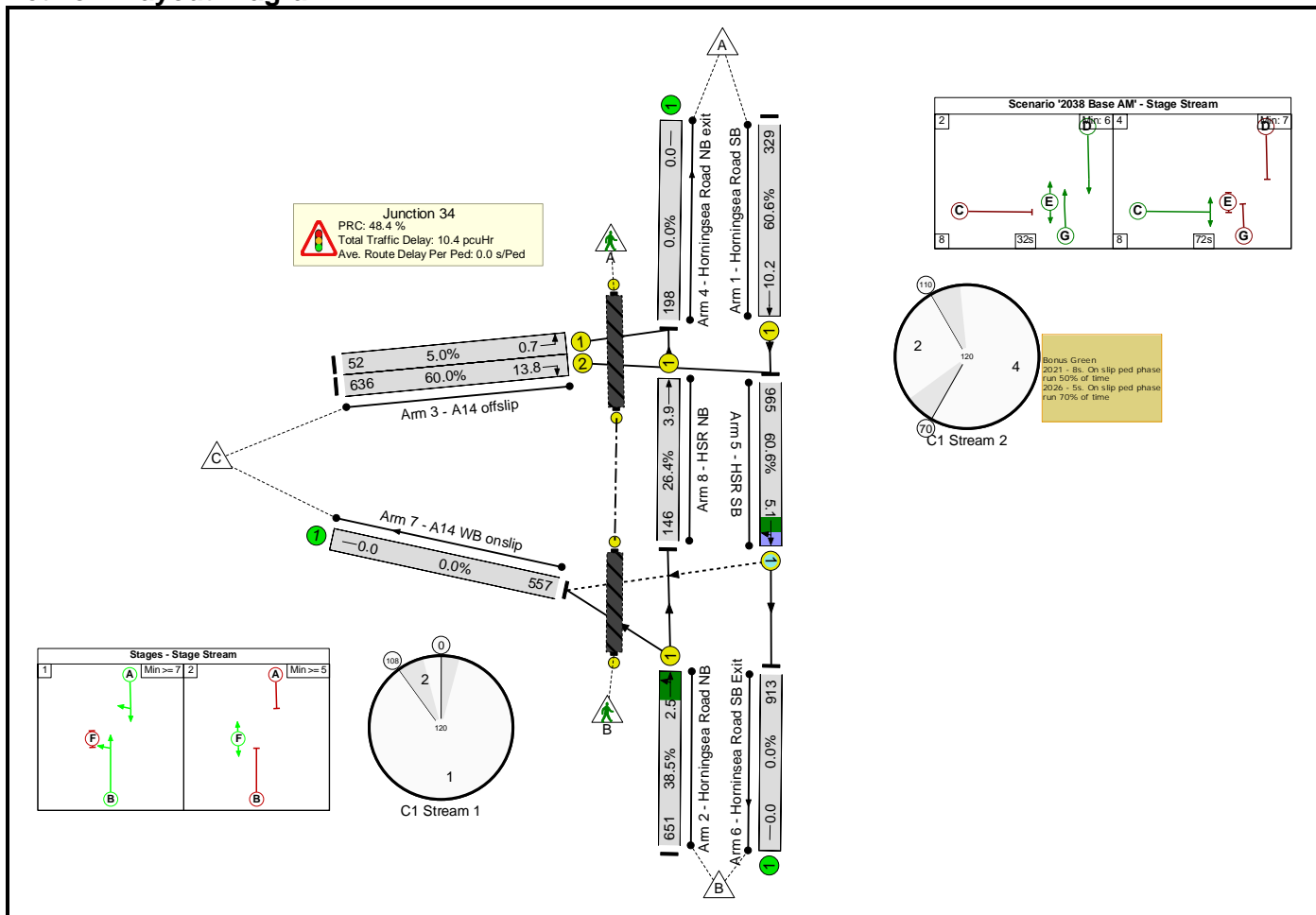

Basic Results Summary

Network Results

Item	Lane Description	Lane Type	Full Phase	Arrow Phase	Num Greens	Total Green (s)	Arrow Green (s)	Demand Flow (pcu)	Sat Flow (pcu/Hr)	Capacity (pcu)	Deg Sat (%)	Turners In Gaps (pcu)	Turners When Unopposed (pcu)	Turners In Intergreen (pcu)	Total Delay (pcuHr)	Av. Delay Per PCU (s/pcu)	Mean Max Queue (pcu)
Network	-	-	-		-	-	-	-	-	-	60.6%	51	1	0	10.4	-	-
Junction 34	-	-	-		-	-	-	-	-	-	60.6%	51	1	0	10.4	-	-
1/1	Horningsea Road SB Ahead	U	D		1	33	-	329	1915	543	60.6%	-	-	-	4.2	45.6	10.2
2/1	Horningsea Road NB Left Ahead	U	B		1	103	-	651	1811	1690	38.5%	-	-	-	0.4	2.1	2.5
3/1	A14 offslip Left	U	C		1	72	-	52	1712	1041	5.0%	-	-	-	0.2	11.3	0.7
3/2	A14 offslip Right	U	C		1	72	-	636	1742	1060	60.0%	-	-	-	3.3	18.7	13.8
5/1	HSR SB Ahead Right	O	A		1	103	-	965	1902	1592	60.6%	51	1	0	0.9	3.4	5.1
8/1	HSR NB Ahead	U	G		1	34	-	146	1895	553	26.4%	-	-	-	1.5	36.6	3.9
Ped Link: P1	Offslip crossing	-	E		1	32	-	0	-	19200	0.0%	-	-	-	0.0	0.0	0.0
Ped Link: P2	Onslip crossing	-	F		1	5	-	0	-	3000	0.0%	-	-	-	0.0	0.0	0.0
							C1 Stream: 1 PRC for Signalled Lanes (%):	48.4	Total Delay for Signalled Lanes (pcuHr):			1.29	Cycle Time (s): 120				
							C1 Stream: 2 PRC for Signalled Lanes (%):	48.4	Total Delay for Signalled Lanes (pcuHr):			9.12	Cycle Time (s): 120				
							PRC Over All Lanes (%):	48.4	Total Delay Over All Lanes(pcuHr):			10.42					

Basic Results Summary

Scenario 10: '2038 Base PM' (FG10: '2038 Base PM', Plan 1: 'Network Control Plan 1')

Network Layout Diagram

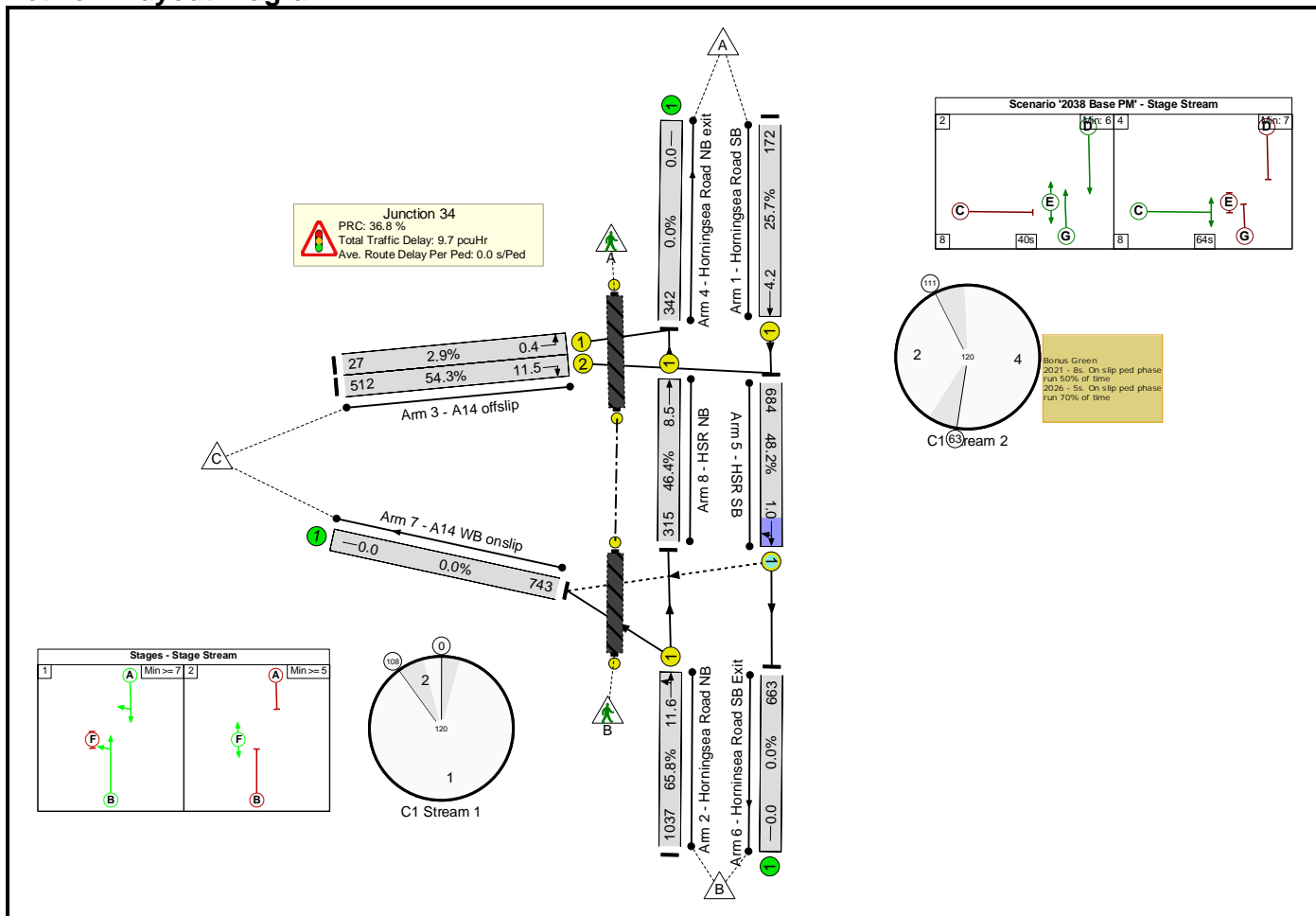

Basic Results Summary

Network Results

Item	Lane Description	Lane Type	Full Phase	Arrow Phase	Num Greens	Total Green (s)	Arrow Green (s)	Demand Flow (pcu)	Sat Flow (pcu/Hr)	Capacity (pcu)	Deg Sat (%)	Turners In Gaps (pcu)	Turners When Unopposed (pcu)	Turners In Intergreen (pcu)	Total Delay (pcuHr)	Av. Delay Per PCU (s/pcu)	Mean Max Queue (pcu)	
Network	-	-	-		-	-	-	-	-	-	65.8%	19	2	0	9.7	-	-	
Junction 34	-	-	-		-	-	-	-	-	-	65.8%	19	2	0	9.7	-	-	
1/1	Horningsea Road SB Ahead	U	D		1	41	-	172	1915	670	25.7%	-	-	-	1.5	31.5	4.2	
2/1	Horningsea Road NB Left Ahead	U	B		1	103	-	1037	1819	1576	65.8%	-	-	-	1.7	5.8	11.6	
3/1	A14 offslip Left	U	C		1	64	-	27	1712	927	2.9%	-	-	-	0.1	14.8	0.4	
3/2	A14 offslip Right	U	C		1	64	-	512	1742	944	54.3%	-	-	-	3.1	22.0	11.5	
5/1	HSR SB Ahead Right	O	A		1	103	-	684	1908	1418	48.2%	19	2	0	0.5	2.8	1.0	
8/1	HSR NB Ahead	U	G		1	42	-	315	1895	679	46.4%	-	-	-	2.8	32.1	8.5	
Ped Link: P1	Offslip crossing	-	E		1	40	-	0	-	24000	0.0%	-	-	-	0.0	0.0	0.0	
Ped Link: P2	Onslip crossing	-	F		1	5	-	0	-	3000	0.0%	-	-	-	0.0	0.0	0.0	
							C1 Stream: 1 PRC for Signalled Lanes (%):	36.8	Total Delay for Signalled Lanes (pcuHr):			2.20	Cycle Time (s):		120			
							C1 Stream: 2 PRC for Signalled Lanes (%):	65.9	Total Delay for Signalled Lanes (pcuHr):			7.55	Cycle Time (s):		120			
							PRC Over All Lanes (%):	36.8	Total Delay Over All Lanes(pcuHr):			9.75						

2 Horningsea Road / Junction 34 of the A14 (proposed lay-out) (LinSig)

- Construction Year 3 (2026) – Construction Peak AM
- Construction Year 3 (2026) – Construction Peak PM
- Construction Year 5 (2028) – Decommissioning AM
- Construction Year 5 (2028) – Decommissioning PM
- Operation Year 1 + 5 (2033) – Operation AM
- Operation Year 1 + 5 (2033) – Operation PM
- Operation Year 1 + 10 (2038) – Operation AM
- Operation Year 1 + 10 (2038) – Operation PM

Basic Results Summary
Basic Results Summary

User and Project Details

Project:	100102041 – AWS Cambridge WWTPRP
Title:	A14 Junction 34
Location:	
Client:	Anglian Water
Date Completed:	19.03.24
Model Purpose:	Proposed Layout
Flow Details:	https://mottmac.sharepoint.com/teams/pj-d2780/do/Develop/06%20-%20Technical%20Disciplines/12%20-%20Transport/13%20%20Documents%20for%20Independent%20Review/1%20Traffic%20flow/Flow%20Diagrams/WIP/Cambridge%20WWTP_Traffic%20Flow%20Diagrams_v3.xlsx?web=1
Checked By:	GW
Checked By Date:	19.03.24
Additional detail:	
File name:	Junction 34 Fen Ditton Junction (4-arm)_v3.lsg3x
Author:	CD
Company:	Mott MacDonald
Address:	

Scenario 1: '2026 Construction AM' (FG7: '2026 Construction AM', Plan 1: 'Network Control Plan 1')

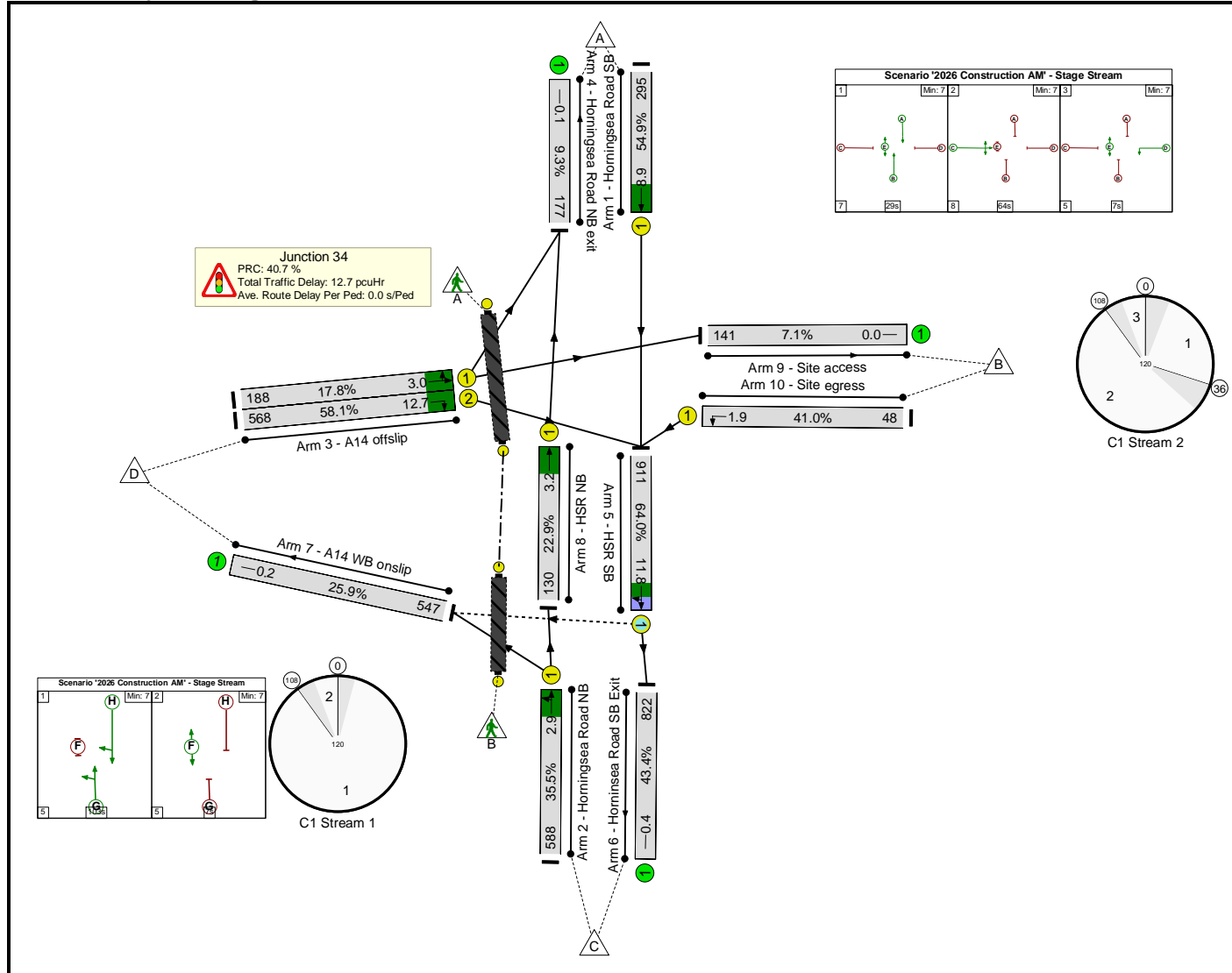

Basic Results Summary

Network Results

Item	Lane Description	Lane Type	Full Phase	Arrow Phase	Num Greens	Total Green (s)	Arrow Green (s)	Demand Flow (pcu)	Sat Flow (pcu/Hr)	Capacity (pcu)	Deg Sat (%)	Turners In Gaps (pcu)	Turners When Unopposed (pcu)	Turners In Intergreen (pcu)	Total Delay (pcuHr)	Av. Delay Per PCU (s/pcu)	Mean Max Queue (pcu)	Item
Network: A14 Junction 34	-	-	-		-	-	-	-	-	-	64.0%	89	0	0	12.7	-	-	Network: A14 Junction 34
Junction 34	-	-	-		-	-	-	-	-	-	64.0%	89	0	0	12.7	-	-	Junction 34
1/1	Horningsea Road SB Ahead	U	A		1	29	-	295	1895	537	54.9%	-	-	-	3.6	43.9	8.9	1/1
2/1	Horningsea Road NB Left Ahead	U	G		1	103	-	588	1822	1655	35.5%	-	-	-	0.4	2.4	2.9	2/1
3/1	A14 offslip Left Ahead	U	C		1	64	-	188	1842	1059	17.8%	-	-	-	0.7	14.1	3.0	3/1
3/2	A14 offslip Right	U	C		1	64	-	568	1699	977	58.1%	-	-	-	3.3	20.7	12.7	3/2
4/1	Horningsea Road NB exit	U	-		-	-	-	177	1895	1895	9.3%	-	-	-	0.1	1.0	0.1	4/1
5/1	HSR SB Ahead Right	O	H		1	103	-	911	1868	1424	64.0%	89	0	0	1.7	6.7	11.8	5/1
6/1	Horninsea Road SB Exit	U	-		-	-	-	822	1895	1895	43.4%	-	-	-	0.4	1.7	0.4	6/1
7/1	A14 WB onslip	U	-		-	-	-	547	2115	2115	25.9%	-	-	-	0.2	1.1	0.2	7/1
8/1	HSR NB Ahead	U	B		1	31	-	130	1895	569	22.9%	-	-	-	1.3	35.6	3.2	8/1
9/1	Site access	U	-		-	-	-	141	1975	1975	7.1%	-	-	-	0.0	1.0	0.0	9/1
10/1	Site egress Left	U	D		1	7	-	48	1756	117	41.0%	-	-	-	1.1	79.6	1.9	10/1
Ped Link: P1	Offslip crossing	-	E		1	43	-	0	-	25800	0.0%	-	-	-	0.0	0.0	0.0	Ped Link: P1
Ped Link: P2	Onslip crossing	-	F		1	7	-	0	-	4200	0.0%	-	-	-	0.0	0.0	0.0	Ped Link: P2

Basic Results Summary

C1	Stream: 1	PRC for Signalled Lanes (%)	40.7	Total Delay for Signalled Lanes (pcuHr)	2.09	Cycle Time (s)	120
C1	Stream: 2	PRC for Signalled Lanes (%)	54.8	Total Delay for Signalled Lanes (pcuHr)	9.94	Cycle Time (s)	120
		PRC Over All Lanes (%)	40.7	Total Delay Over All Lanes(pcuHr)	12.67		

Basic Results Summary

Scenario 2: '2026 Construction PM' (FG8: '2026 Construction PM', Plan 1: 'Network Control Plan 1')

Network Layout Diagram

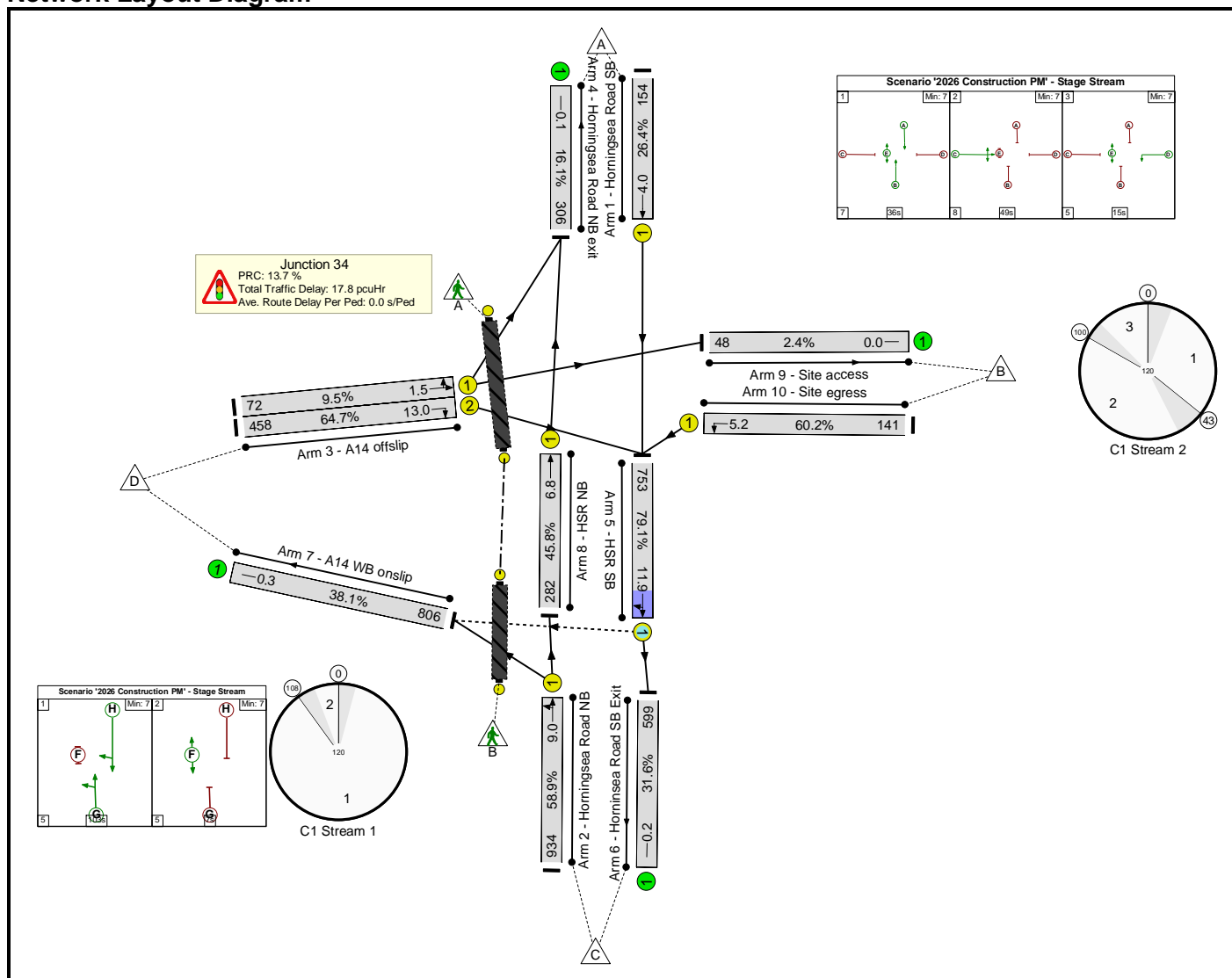

Basic Results Summary

Network Results

Item	Lane Description	Lane Type	Full Phase	Arrow Phase	Num Greens	Total Green (s)	Arrow Green (s)	Demand Flow (pcu)	Sat Flow (pcu/Hr)	Capacity (pcu)	Deg Sat (%)	Turners In Gaps (pcu)	Turners When Unopposed (pcu)	Turners In Intergreen (pcu)	Total Delay (pcuHr)	Av. Delay Per PCU (s/pcu)	Mean Max Queue (pcu)	Item
Network: A14 Junction 34	-	-	-		-	-	-	-	-	-	79.1%	131	23	0	17.8	-	-	Network: A14 Junction 34
Junction 34	-	-	-		-	-	-	-	-	-	79.1%	131	23	0	17.8	-	-	Junction 34
1/1	Horningsea Road SB Ahead	U	A		1	36	-	154	1895	584	26.4%	-	-	-	1.5	35.4	4.0	1/1
2/1	Horningsea Road NB Left Ahead	U	G		1	103	-	934	1829	1585	58.9%	-	-	-	1.3	4.9	9.0	2/1
3/1	A14 offslip Left Ahead	U	C		1	49	-	72	1825	760	9.5%	-	-	-	0.5	23.9	1.5	3/1
3/2	A14 offslip Right	U	C		1	49	-	458	1699	708	64.7%	-	-	-	4.5	35.1	13.0	3/2
4/1	Horningsea Road NB exit	U	-		-	-	-	306	1895	1895	16.1%	-	-	-	0.1	1.1	0.1	4/1
5/1	HSR SB Ahead Right	O	H		1	103	-	753	1839	951	79.1%	131	23	0	4.0	18.9	11.9	5/1
6/1	Horninsea Road SB Exit	U	-		-	-	-	599	1895	1895	31.6%	-	-	-	0.2	1.4	0.2	6/1
7/1	A14 WB onslip	U	-		-	-	-	806	2115	2115	38.1%	-	-	-	0.3	1.4	0.3	7/1
8/1	HSR NB Ahead	U	B		1	38	-	282	1895	616	45.8%	-	-	-	2.8	35.9	6.8	8/1
9/1	Site access	U	-		-	-	-	48	1975	1975	2.4%	-	-	-	0.0	0.9	0.0	9/1
10/1	Site egress Left	U	D		1	15	-	141	1756	234	60.2%	-	-	-	2.7	68.0	5.2	10/1
Ped Link: P1	Offslip crossing	-	E		1	58	-	0	-	34800	0.0%	-	-	-	0.0	0.0	0.0	Ped Link: P1
Ped Link: P2	Onslip crossing	-	F		1	7	-	0	-	4200	0.0%	-	-	-	0.0	0.0	0.0	Ped Link: P2

Basic Results Summary

C1	Stream: 1	PRC for Signalled Lanes (%)	13.7	Total Delay for Signalled Lanes (pcuHr)	5.24	Cycle Time (s)	120
C1	Stream: 2	PRC for Signalled Lanes (%)	39.1	Total Delay for Signalled Lanes (pcuHr)	11.93	Cycle Time (s)	120
		PRC Over All Lanes (%)	13.7	Total Delay Over All Lanes(pcuHr)	17.82		

Basic Results Summary

Scenario 3: '2028 Decommissioning AM' (FG5: '2028 Decommissioning AM', Plan 1: 'Network Control Plan 1')

Network Layout Diagram

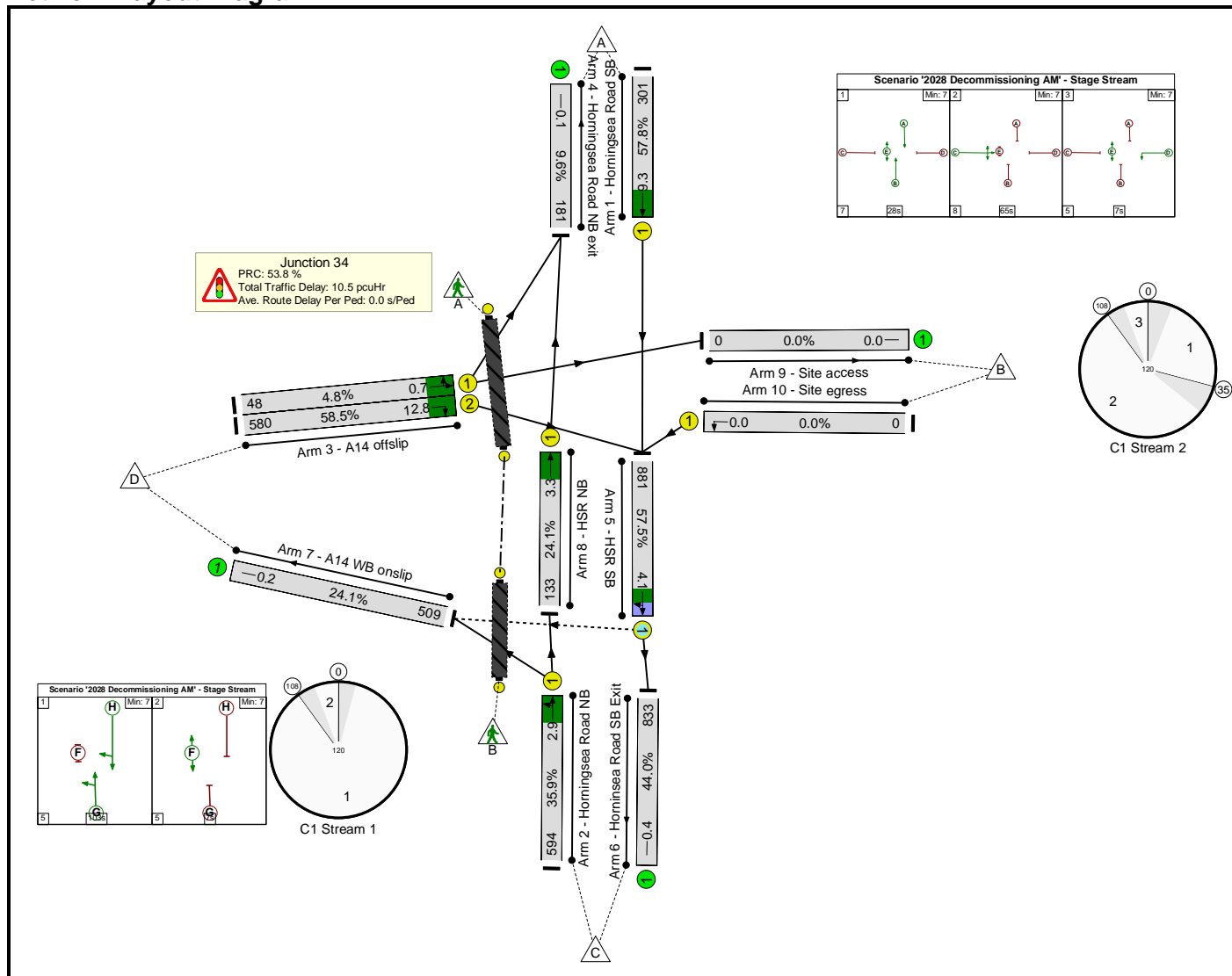

Basic Results Summary

Network Results

Item	Lane Description	Lane Type	Full Phase	Arrow Phase	Num Greens	Total Green (s)	Arrow Green (s)	Demand Flow (pcu)	Sat Flow (pcu/Hr)	Capacity (pcu)	Deg Sat (%)	Turners In Gaps (pcu)	Turners When Unopposed (pcu)	Turners In Intergreen (pcu)	Total Delay (pcuHr)	Av. Delay Per PCU (s/pcu)	Mean Max Queue (pcu)	Item
Network: A14 Junction 34	-	-	-		-	-	-	-	-	-	58.5%	48	0	0	10.5	-	-	Network: A14 Junction 34
Junction 34	-	-	-		-	-	-	-	-	-	58.5%	48	0	0	10.5	-	-	Junction 34
1/1	Horningsea Road SB Ahead	U	A		1	28	-	301	1895	521	57.8%	-	-	-	3.8	45.6	9.3	1/1
2/1	Horningsea Road NB Left Ahead	U	G		1	103	-	594	1822	1655	35.9%	-	-	-	0.4	2.4	2.9	2/1
3/1	A14 offslip Left Ahead	U	C		1	65	-	48	1699	991	4.8%	-	-	-	0.2	12.7	0.7	3/1
3/2	A14 offslip Right	U	C		1	65	-	580	1699	991	58.5%	-	-	-	3.3	20.2	12.8	3/2
4/1	Horningsea Road NB exit	U	-		-	-	-	181	1895	1895	9.6%	-	-	-	0.1	1.1	0.1	4/1
5/1	HSR SB Ahead Right	O	H		1	103	-	881	1880	1532	57.5%	48	0	0	0.9	3.6	4.1	5/1
6/1	Horninsea Road SB Exit	U	-		-	-	-	833	1895	1895	44.0%	-	-	-	0.4	1.7	0.4	6/1
7/1	A14 WB onslip	U	-		-	-	-	509	2115	2115	24.1%	-	-	-	0.2	1.1	0.2	7/1
8/1	HSR NB Ahead	U	B		1	30	-	133	1895	553	24.1%	-	-	-	1.3	36.5	3.3	8/1
9/1	Site access	U	-		-	-	-	0	1975	1975	0.0%	-	-	-	0.0	0.0	0.0	9/1
10/1	Site egress Left	U	D		1	7	-	0	1975	132	0.0%	-	-	-	0.0	0.0	0.0	10/1
Ped Link: P1	Offslip crossing	-	E		1	42	-	0	-	25200	0.0%	-	-	-	0.0	0.0	0.0	Ped Link: P1
Ped Link: P2	Onslip crossing	-	F		1	7	-	0	-	4200	0.0%	-	-	-	0.0	0.0	0.0	Ped Link: P2

Basic Results Summary

C1	Stream: 1	PRC for Signalled Lanes (%)	56.5	Total Delay for Signalled Lanes (pcuHr)	1.27	Cycle Time (s)	120
C1	Stream: 2	PRC for Signalled Lanes (%)	53.8	Total Delay for Signalled Lanes (pcuHr)	8.58	Cycle Time (s)	120
		PRC Over All Lanes (%)	53.8	Total Delay Over All Lanes(pcuHr)	10.46		

Basic Results Summary

Scenario 4: '2028 Decommissioning PM' (FG6: '2028 Decommissioning PM', Plan 1: 'Network Control Plan 1')

Network Layout Diagram

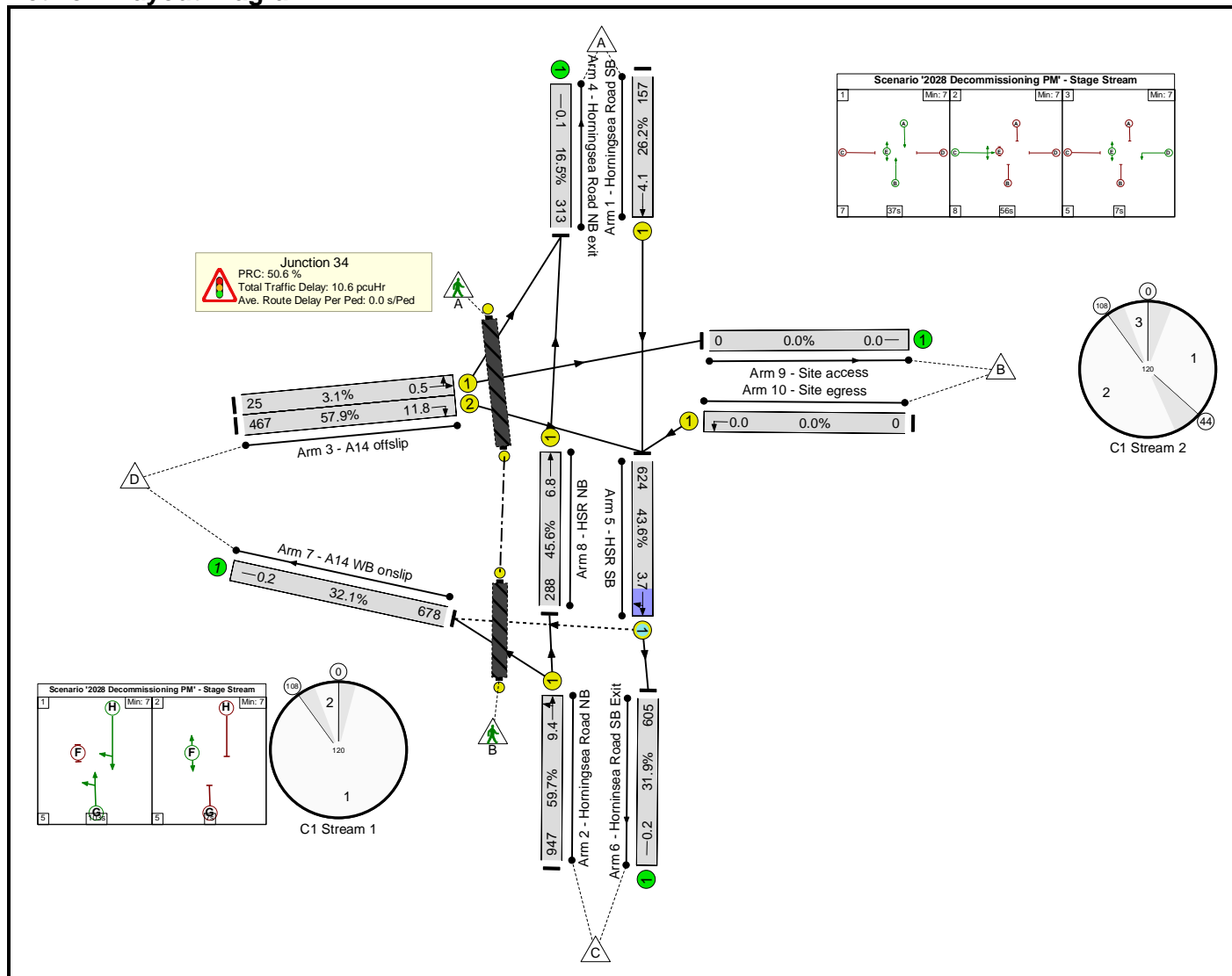

Basic Results Summary

Network Results

Item	Lane Description	Lane Type	Full Phase	Arrow Phase	Num Greens	Total Green (s)	Arrow Green (s)	Demand Flow (pcu)	Sat Flow (pcu/Hr)	Capacity (pcu)	Deg Sat (%)	Turners In Gaps (pcu)	Turners When Unopposed (pcu)	Turners In Intergreen (pcu)	Total Delay (pcuHr)	Av. Delay Per PCU (s/pcu)	Mean Max Queue (pcu)	Item
Network: A14 Junction 34	-	-	-		-	-	-	-	-	-	59.7%	19	0	0	10.6	-	-	Network: A14 Junction 34
Junction 34	-	-	-		-	-	-	-	-	-	59.7%	19	0	0	10.6	-	-	Junction 34
1/1	Horningsea Road SB Ahead	U	A		1	37	-	157	1895	600	26.2%	-	-	-	1.5	34.6	4.1	1/1
2/1	Horningsea Road NB Left Ahead	U	G		1	103	-	947	1829	1585	59.7%	-	-	-	1.3	5.0	9.4	2/1
3/1	A14 offslip Left Ahead	U	C		1	56	-	25	1699	807	3.1%	-	-	-	0.1	19.1	0.5	3/1
3/2	A14 offslip Right	U	C		1	56	-	467	1699	807	57.9%	-	-	-	3.6	28.1	11.8	3/2
4/1	Horningsea Road NB exit	U	-		-	-	-	313	1895	1895	16.5%	-	-	-	0.1	1.1	0.1	4/1
5/1	HSR SB Ahead Right	O	H		1	103	-	624	1886	1432	43.6%	19	0	0	0.6	3.7	3.7	5/1
6/1	Horninsea Road SB Exit	U	-		-	-	-	605	1895	1895	31.9%	-	-	-	0.2	1.4	0.2	6/1
7/1	A14 WB onslip	U	-		-	-	-	678	2115	2115	32.1%	-	-	-	0.2	1.3	0.2	7/1
8/1	HSR NB Ahead	U	B		1	39	-	288	1895	632	45.6%	-	-	-	2.8	35.0	6.8	8/1
9/1	Site access	U	-		-	-	-	0	1975	1975	0.0%	-	-	-	0.0	0.0	0.0	9/1
10/1	Site egress Left	U	D		1	7	-	0	1975	132	0.0%	-	-	-	0.0	0.0	0.0	10/1
Ped Link: P1	Offslip crossing	-	E		1	51	-	0	-	30600	0.0%	-	-	-	0.0	0.0	0.0	Ped Link: P1
Ped Link: P2	Onslip crossing	-	F		1	7	-	0	-	4200	0.0%	-	-	-	0.0	0.0	0.0	Ped Link: P2

Basic Results Summary

C1	Stream: 1	PRC for Signalled Lanes (%)	50.6	Total Delay for Signalled Lanes (pcuHr)	1.97	Cycle Time (s)	120
C1	Stream: 2	PRC for Signalled Lanes (%)	55.5	Total Delay for Signalled Lanes (pcuHr)	8.09	Cycle Time (s)	120
		PRC Over All Lanes (%)	50.6	Total Delay Over All Lanes(pcuHr)	10.62		

Basic Results Summary

Scenario 5: '2033 Operational AM' (FG1: '2033 Operation AM', Plan 1: 'Network Control Plan 1')

Network Layout Diagram

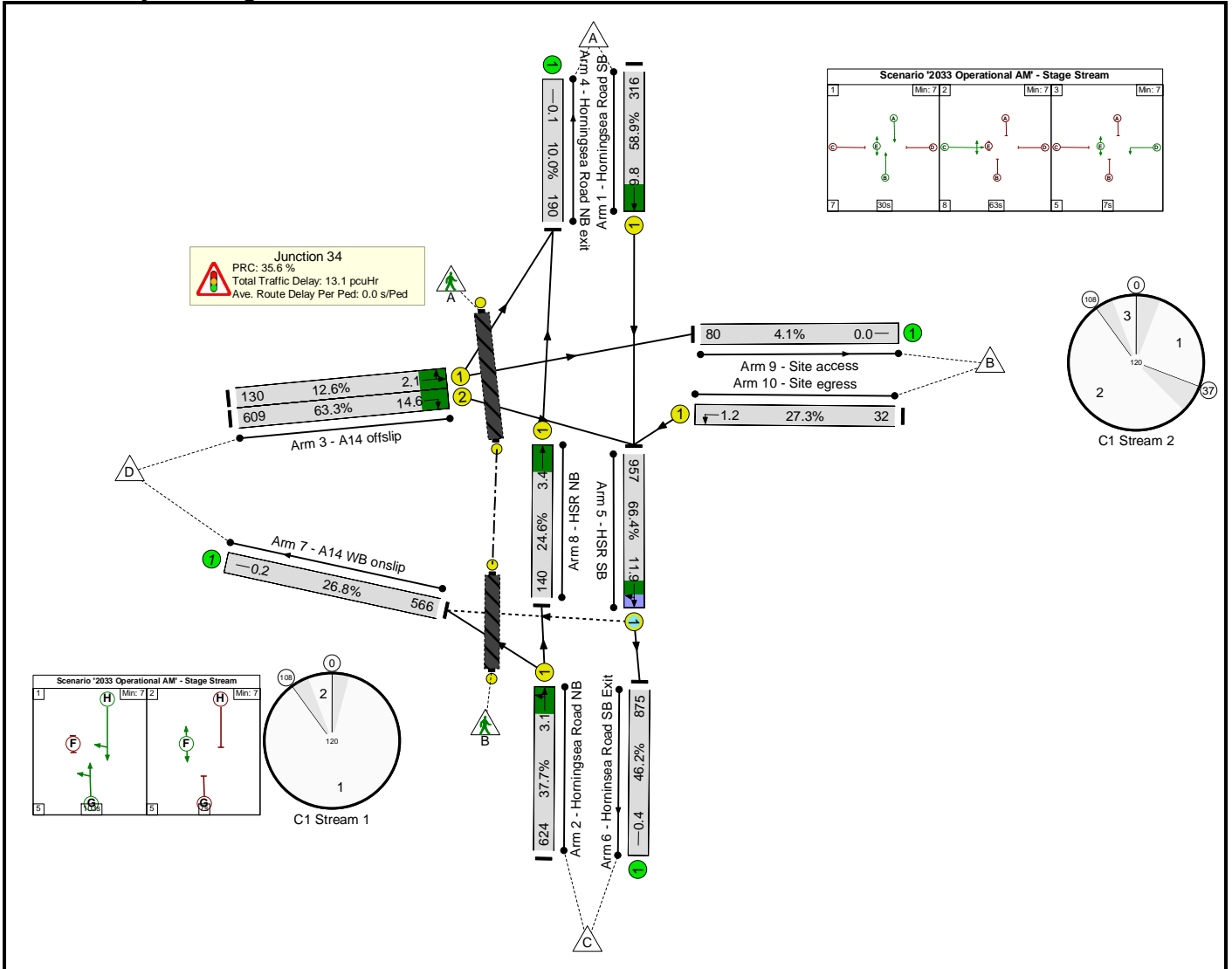

Basic Results Summary

Network Results

Item	Lane Description	Lane Type	Full Phase	Arrow Phase	Num Greens	Total Green (s)	Arrow Green (s)	Demand Flow (pcu)	Sat Flow (pcu/Hr)	Capacity (pcu)	Deg Sat (%)	Turners In Gaps (pcu)	Turners When Unopposed (pcu)	Turners In Intergreen (pcu)	Total Delay (pcuHr)	Av. Delay Per PCU (s/pcu)	Mean Max Queue (pcu)	Item
Network: A14 Junction 34	-	-	-		-	-	-	-	-	-	66.4%	82	0	0	13.1	-	-	Network: A14 Junction 34
Junction 34	-	-	-		-	-	-	-	-	-	66.4%	82	0	0	13.1	-	-	Junction 34
1/1	Horningsea Road SB Ahead	U	A		1	30	-	316	1895	537	58.9%	-	-	-	4.0	45.1	9.8	1/1
2/1	Horningsea Road NB Left Ahead	U	G		1	103	-	624	1822	1655	37.7%	-	-	-	0.4	2.5	3.1	2/1
3/1	A14 offslip Left Ahead	U	C		1	63	-	130	1814	1028	12.6%	-	-	-	0.5	14.1	2.1	3/1
3/2	A14 offslip Right	U	C		1	63	-	609	1699	963	63.3%	-	-	-	3.8	22.6	14.6	3/2
4/1	Horningsea Road NB exit	U	-		-	-	-	190	1895	1895	10.0%	-	-	-	0.1	1.1	0.1	4/1
5/1	HSR SB Ahead Right	O	H		1	103	-	957	1871	1442	66.4%	82	0	0	1.7	6.2	11.9	5/1
6/1	Horninsea Road SB Exit	U	-		-	-	-	875	1895	1895	46.2%	-	-	-	0.4	1.8	0.4	6/1
7/1	A14 WB onslip	U	-		-	-	-	566	2115	2115	26.8%	-	-	-	0.2	1.2	0.2	7/1
8/1	HSR NB Ahead	U	B		1	32	-	140	1895	569	24.6%	-	-	-	1.4	35.8	3.4	8/1
9/1	Site access	U	-		-	-	-	80	1975	1975	4.1%	-	-	-	0.0	0.9	0.0	9/1
10/1	Site egress Left	U	D		1	7	-	32	1756	117	27.3%	-	-	-	0.7	74.3	1.2	10/1
Ped Link: P1	Offslip crossing	-	E		1	44	-	0	-	26400	0.0%	-	-	-	0.0	0.0	0.0	Ped Link: P1
Ped Link: P2	Onslip crossing	-	F		1	7	-	0	-	4200	0.0%	-	-	-	0.0	0.0	0.0	Ped Link: P2

Basic Results Summary

C1	Stream: 1	PRC for Signalled Lanes (%)	35.6	Total Delay for Signalled Lanes (pcuHr)	2.09	Cycle Time (s)	120
C1	Stream: 2	PRC for Signalled Lanes (%)	42.3	Total Delay for Signalled Lanes (pcuHr)	10.35	Cycle Time (s)	120
		PRC Over All Lanes (%)	35.6	Total Delay Over All Lanes(pcuHr)	13.13		

Basic Results Summary

Scenario 6: '2033 Operational PM' (FG2: '2033 Operation PM ', Plan 1: 'Network Control Plan 1')

Network Layout Diagram

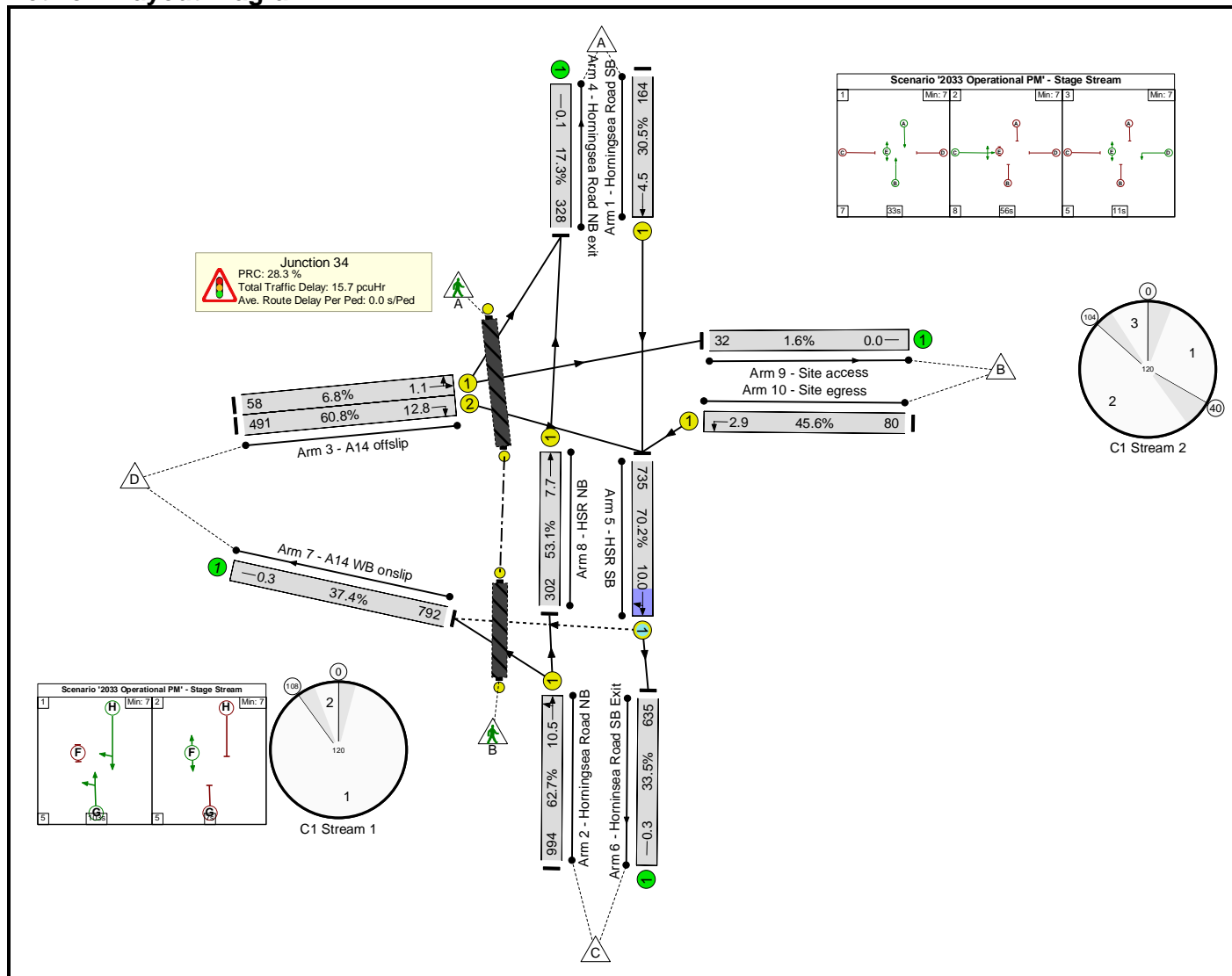

Basic Results Summary

Network Results

Item	Lane Description	Lane Type	Full Phase	Arrow Phase	Num Greens	Total Green (s)	Arrow Green (s)	Demand Flow (pcu)	Sat Flow (pcu/Hr)	Capacity (pcu)	Deg Sat (%)	Turners In Gaps (pcu)	Turners When Unopposed (pcu)	Turners In Intergreen (pcu)	Total Delay (pcuHr)	Av. Delay Per PCU (s/pcu)	Mean Max Queue (pcu)	Item
Network: A14 Junction 34	-	-	-		-	-	-	-	-	-	70.2%	91	9	0	15.7	-	-	Network: A14 Junction 34
Junction 34	-	-	-		-	-	-	-	-	-	70.2%	91	9	0	15.7	-	-	Junction 34
1/1	Horningsea Road SB Ahead	U	A		1	33	-	164	1895	537	30.5%	-	-	-	1.8	38.6	4.5	1/1
2/1	Horningsea Road NB Left Ahead	U	G		1	103	-	994	1829	1585	62.7%	-	-	-	1.5	5.4	10.5	2/1
3/1	A14 offslip Left Ahead	U	C		1	56	-	58	1802	856	6.8%	-	-	-	0.3	19.4	1.1	3/1
3/2	A14 offslip Right	U	C		1	56	-	491	1699	807	60.8%	-	-	-	3.9	28.9	12.8	3/2
4/1	Horningsea Road NB exit	U	-		-	-	-	328	1895	1895	17.3%	-	-	-	0.1	1.1	0.1	4/1
5/1	HSR SB Ahead Right	O	H		1	103	-	735	1857	1048	70.2%	91	9	0	2.7	13.2	10.0	5/1
6/1	Horninsea Road SB Exit	U	-		-	-	-	635	1895	1895	33.5%	-	-	-	0.3	1.4	0.3	6/1
7/1	A14 WB onslip	U	-		-	-	-	792	2115	2115	37.4%	-	-	-	0.3	1.4	0.3	7/1
8/1	HSR NB Ahead	U	B		1	35	-	302	1895	569	53.1%	-	-	-	3.3	39.9	7.7	8/1
9/1	Site access	U	-		-	-	-	32	1975	1975	1.6%	-	-	-	0.0	0.9	0.0	9/1
10/1	Site egress Left	U	D		1	11	-	80	1756	176	45.6%	-	-	-	1.5	69.6	2.9	10/1
Ped Link: P1	Offslip crossing	-	E		1	51	-	0	-	30600	0.0%	-	-	-	0.0	0.0	0.0	Ped Link: P1
Ped Link: P2	Onslip crossing	-	F		1	7	-	0	-	4200	0.0%	-	-	-	0.0	0.0	0.0	Ped Link: P2

Basic Results Summary

C1	Stream: 1	PRC for Signalled Lanes (%)	28.3	Total Delay for Signalled Lanes (pcuHr)	4.17	Cycle Time (s)	120
C1	Stream: 2	PRC for Signalled Lanes (%)	47.9	Total Delay for Signalled Lanes (pcuHr)	10.91	Cycle Time (s)	120
		PRC Over All Lanes (%)	28.3	Total Delay Over All Lanes(pcuHr)	15.75		

Basic Results Summary

Scenario 7: '2038 Operational AM' (FG3: '2038 Operational AM', Plan 1: 'Network Control Plan 1')

Network Layout Diagram

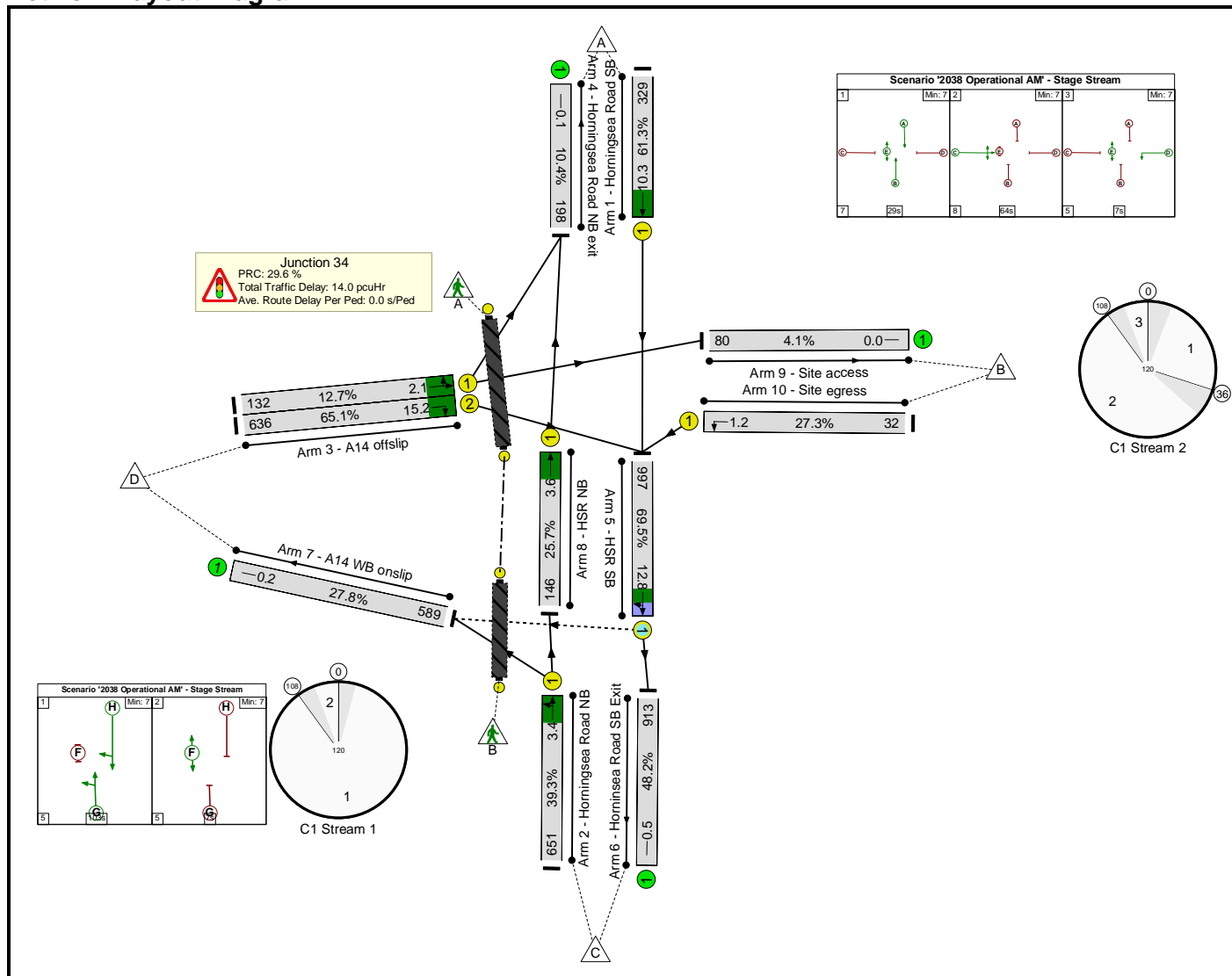

Basic Results Summary

Network Results

Item	Lane Description	Lane Type	Full Phase	Arrow Phase	Num Greens	Total Green (s)	Arrow Green (s)	Demand Flow (pcu)	Sat Flow (pcu/Hr)	Capacity (pcu)	Deg Sat (%)	Turners In Gaps (pcu)	Turners When Unopposed (pcu)	Turners In Intergreen (pcu)	Total Delay (pcuHr)	Av. Delay Per PCU (s/pcu)	Mean Max Queue (pcu)	Item
Network: A14 Junction 34	-	-	-		-	-	-	-	-	-	69.5%	84	0	0	14.0	-	-	Network: A14 Junction 34
Junction 34	-	-	-		-	-	-	-	-	-	69.5%	84	0	0	14.0	-	-	Junction 34
1/1	Horningsea Road SB Ahead	U	A		1	29	-	329	1895	537	61.3%	-	-	-	4.2	45.9	10.3	1/1
2/1	Horningsea Road NB Left Ahead	U	G		1	103	-	651	1822	1655	39.3%	-	-	-	0.5	2.6	3.4	2/1
3/1	A14 offslip Left Ahead	U	C		1	64	-	132	1813	1042	12.7%	-	-	-	0.5	13.7	2.1	3/1
3/2	A14 offslip Right	U	C		1	64	-	636	1699	977	65.1%	-	-	-	4.0	22.6	15.2	3/2
4/1	Horningsea Road NB exit	U	-		-	-	-	198	1895	1895	10.4%	-	-	-	0.1	1.1	0.1	4/1
5/1	HSR SB Ahead Right	O	H		1	103	-	997	1871	1436	69.5%	84	0	0	2.0	7.2	12.8	5/1
6/1	Horninsea Road SB Exit	U	-		-	-	-	913	1895	1895	48.2%	-	-	-	0.5	1.8	0.5	6/1
7/1	A14 WB onslip	U	-		-	-	-	589	2115	2115	27.8%	-	-	-	0.2	1.2	0.2	7/1
8/1	HSR NB Ahead	U	B		1	31	-	146	1895	569	25.7%	-	-	-	1.5	36.0	3.6	8/1
9/1	Site access	U	-		-	-	-	80	1975	1975	4.1%	-	-	-	0.0	0.9	0.0	9/1
10/1	Site egress Left	U	D		1	7	-	32	1756	117	27.3%	-	-	-	0.7	74.3	1.2	10/1
Ped Link: P1	Offslip crossing	-	E		1	43	-	0	-	25800	0.0%	-	-	-	0.0	0.0	0.0	Ped Link: P1
Ped Link: P2	Onslip crossing	-	F		1	7	-	0	-	4200	0.0%	-	-	-	0.0	0.0	0.0	Ped Link: P2

Basic Results Summary

C1	Stream: 1	PRC for Signalled Lanes (%)	29.6	Total Delay for Signalled Lanes (pcuHr)	2.45	Cycle Time (s)	120
C1	Stream: 2	PRC for Signalled Lanes (%)	38.2	Total Delay for Signalled Lanes (pcuHr)	10.80	Cycle Time (s)	120
		PRC Over All Lanes (%)	29.6	Total Delay Over All Lanes(pcuHr)	13.99		

Basic Results Summary

Scenario 8: '2038 Opoeational PM' (FG4: '2038 Operational PM', Plan 1: 'Network Control Plan 1')

Network Layout Diagram

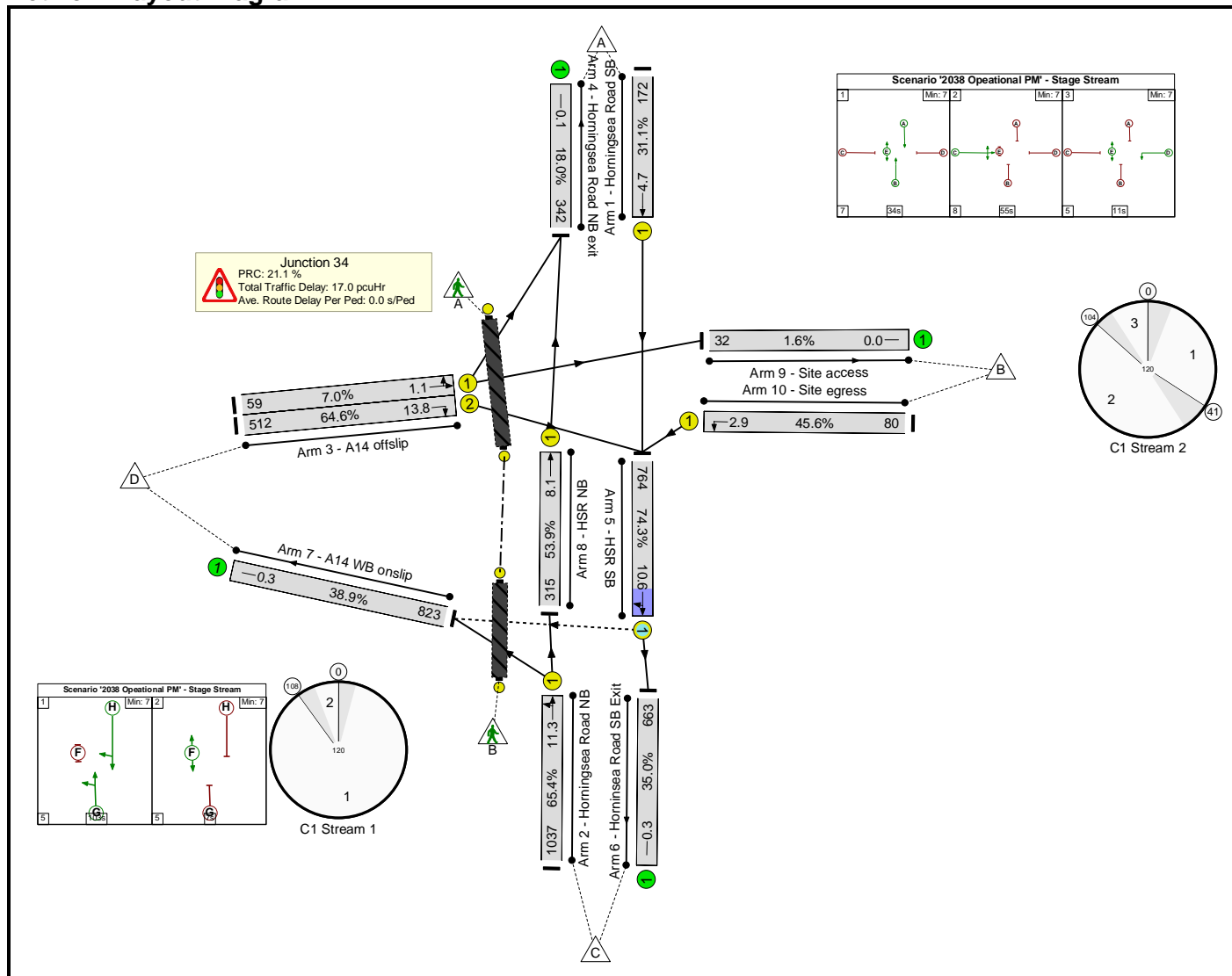

Basic Results Summary

Network Results

Item	Lane Description	Lane Type	Full Phase	Arrow Phase	Num Greens	Total Green (s)	Arrow Green (s)	Demand Flow (pcu)	Sat Flow (pcu/Hr)	Capacity (pcu)	Deg Sat (%)	Turners In Gaps (pcu)	Turners When Unopposed (pcu)	Turners In Intergreen (pcu)	Total Delay (pcuHr)	Av. Delay Per PCU (s/pcu)	Mean Max Queue (pcu)	Item
Network: A14 Junction 34	-	-	-		-	-	-	-	-	-	74.3%	93	8	0	17.0	-	-	Network: A14 Junction 34
Junction 34	-	-	-		-	-	-	-	-	-	74.3%	93	8	0	17.0	-	-	Junction 34
1/1	Horningsea Road SB Ahead	U	A		1	34	-	172	1895	553	31.1%	-	-	-	1.8	37.8	4.7	1/1
2/1	Horningsea Road NB Left Ahead	U	G		1	103	-	1037	1829	1585	65.4%	-	-	-	1.7	5.7	11.3	2/1
3/1	A14 offslip Left Ahead	U	C		1	55	-	59	1800	840	7.0%	-	-	-	0.3	20.0	1.1	3/1
3/2	A14 offslip Right	U	C		1	55	-	512	1699	793	64.6%	-	-	-	4.4	30.8	13.8	3/2
4/1	Horningsea Road NB exit	U	-		-	-	-	342	1895	1895	18.0%	-	-	-	0.1	1.2	0.1	4/1
5/1	HSR SB Ahead Right	O	H		1	103	-	764	1858	1028	74.3%	93	8	0	3.2	14.9	10.6	5/1
6/1	Horninsea Road SB Exit	U	-		-	-	-	663	1895	1895	35.0%	-	-	-	0.3	1.5	0.3	6/1
7/1	A14 WB onslip	U	-		-	-	-	823	2115	2115	38.9%	-	-	-	0.3	1.4	0.3	7/1
8/1	HSR NB Ahead	U	B		1	36	-	315	1895	584	53.9%	-	-	-	3.4	39.3	8.1	8/1
9/1	Site access	U	-		-	-	-	32	1975	1975	1.6%	-	-	-	0.0	0.9	0.0	9/1
10/1	Site egress Left	U	D		1	11	-	80	1756	176	45.6%	-	-	-	1.5	69.6	2.9	10/1
Ped Link: P1	Offslip crossing	-	E		1	52	-	0	-	31200	0.0%	-	-	-	0.0	0.0	0.0	Ped Link: P1
Ped Link: P2	Onslip crossing	-	F		1	7	-	0	-	4200	0.0%	-	-	-	0.0	0.0	0.0	Ped Link: P2

Basic Results Summary

C1	Stream: 1	PRC for Signalled Lanes (%)	21.1	Total Delay for Signalled Lanes (pcuHr)	4.82	Cycle Time (s)	120
C1	Stream: 2	PRC for Signalled Lanes (%)	39.4	Total Delay for Signalled Lanes (pcuHr)	11.50	Cycle Time (s)	120
		PRC Over All Lanes (%)	21.1	Total Delay Over All Lanes(pcuHr)	17.02		

3 A10 / Denny End Road (LinSig)

- 2021 Baseline AM
- 2021 Baseline PM
- Construction Year 3 (2026) – Future Baseline AM
- Construction Year 3 (2026) – Future Baseline PM
- Construction Year 3 (2026) – Construction Peak AM
- Construction Year 3 (2026) – Construction Peak PM

Basic Results Summary
Basic Results Summary

User and Project Details

Project:	100102041 – AWS Cambridge WWTPRP
Title:	A10/Denny End Road
Location:	
Client:	Anglian Water
Date Completed:	07.02.24
Model Purpose:	
Model Assumptions:	
Flow Details:	https://mottmac.sharepoint.com/:x:/r/teams/pj-d2780/do/Develop/06%20-%20Technical%20Disciplines/12%20-%20Transport/03%20Technical%20Analysis/Traffic%20Flow%20Diagrams/Version%202%20-%20January%202024/Cambridge%20WWTP_Traffic%20Flow%20Diagram.ms.xlsx?d=w4f367f2dfb614195b49eedda3869d06c&csf=1&web=1&e=cAWS2S
Checked By:	TE
Additional detail:	
File name:	A10_Denny End.lsg3x
Author:	ZB
Company:	Mott MacDonald
Address:	

Scenario 1: '2021 Base AM' (FG1: '2021 Base AM', Plan 1: 'Network Control Plan 1')
Network Layout Diagram

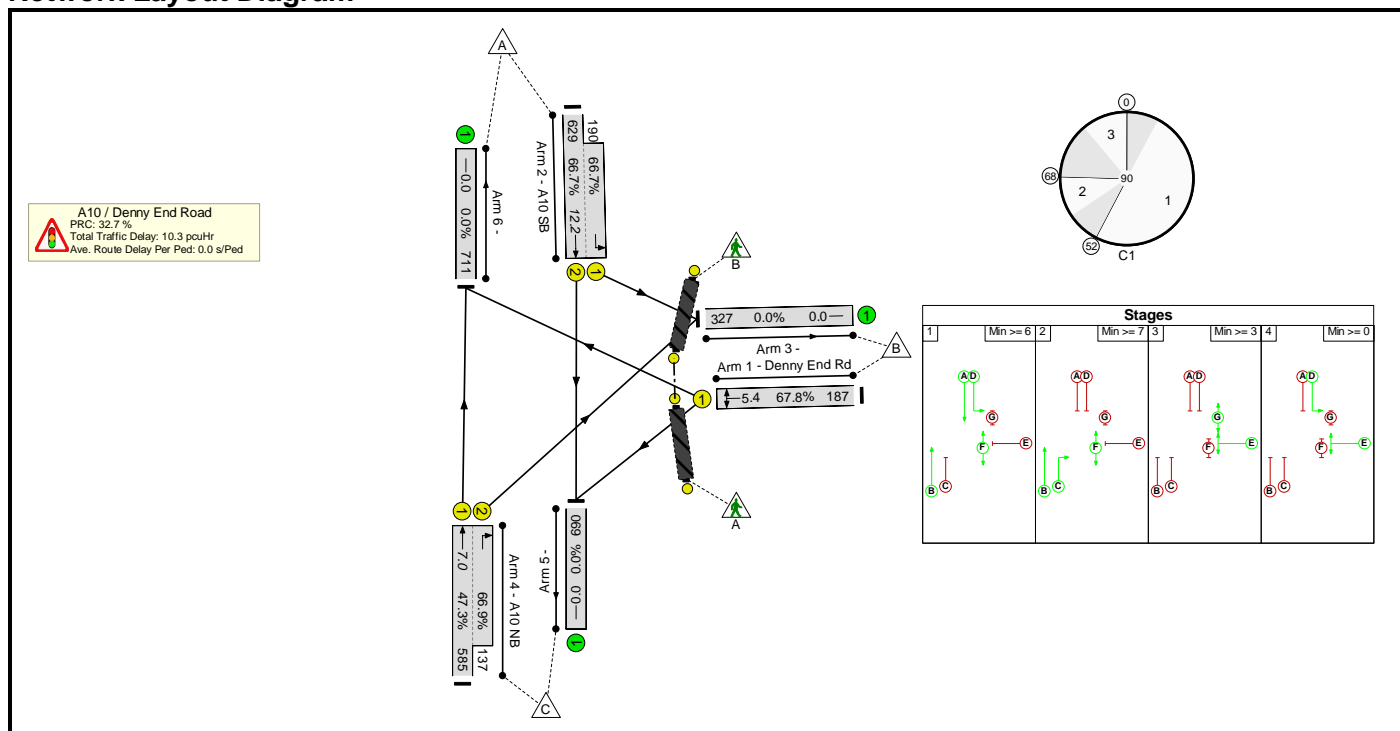

Basic Results Summary

Network Results

Item	Lane Description	Lane Type	Full Phase	Arrow Phase	Num Greens	Total Green (s)	Arrow Green (s)	Demand Flow (pcu)	Sat Flow (pcu/Hr)	Capacity (pcu)	Deg Sat (%)	Turners In Gaps (pcu)	Turners When Unopposed (pcu)	Turners In Intergreen (pcu)	Total Delay (pcuHr)	Av. Delay Per PCU (s/pcu)	Mean Max Queue (pcu)	
Network: AWS Cambridge WWTPRP EIA Stage 2	-	-	-		-	-	-	-	-	-	67.8%	0	0	0	10.3	-	-	
A10 / Denny End Road	-	-	-		-	-	-	-	-	-	67.8%	0	0	0	10.3	-	-	
1/1	Denny End Rd Left Right	U	E		1	13	-	187	1773	276	67.8%	-	-	-	2.9	55.7	5.4	
2/2+2/1	A10 SB Left Ahead	U	A D		1	45	-	819	1965:1774	943+285	66.7 : 66.7%	-	-	-	4.4	19.3	12.2	
4/1+4/2	A10 NB Right Ahead	U	B C		1	61:9	-	722	1940:1842	1236+205	47.3 : 66.9%	-	-	-	3.0	14.8	7.0	
Ped Link: P1	Unnamed Ped Link	-	F		1	61	-	0	-	48800	0.0%	-	-	-	0.0	0.0	0.0	
Ped Link: P2	Unnamed Ped Link	-	G		1	10	-	0	-	8000	0.0%	-	-	-	0.0	0.0	0.0	
C1					PRC for Signalled Lanes (%):		32.7	Total Delay for Signalled Lanes (pcuHr):				10.27	Cycle Time (s):		90			
					PRC Over All Lanes (%):		32.7	Total Delay Over All Lanes(pcuHr):				10.27						

Basic Results Summary

Scenario 2: '2021 Base PM' (FG2: '2021 Base PM', Plan 1: 'Network Control Plan 1')

Network Layout Diagram

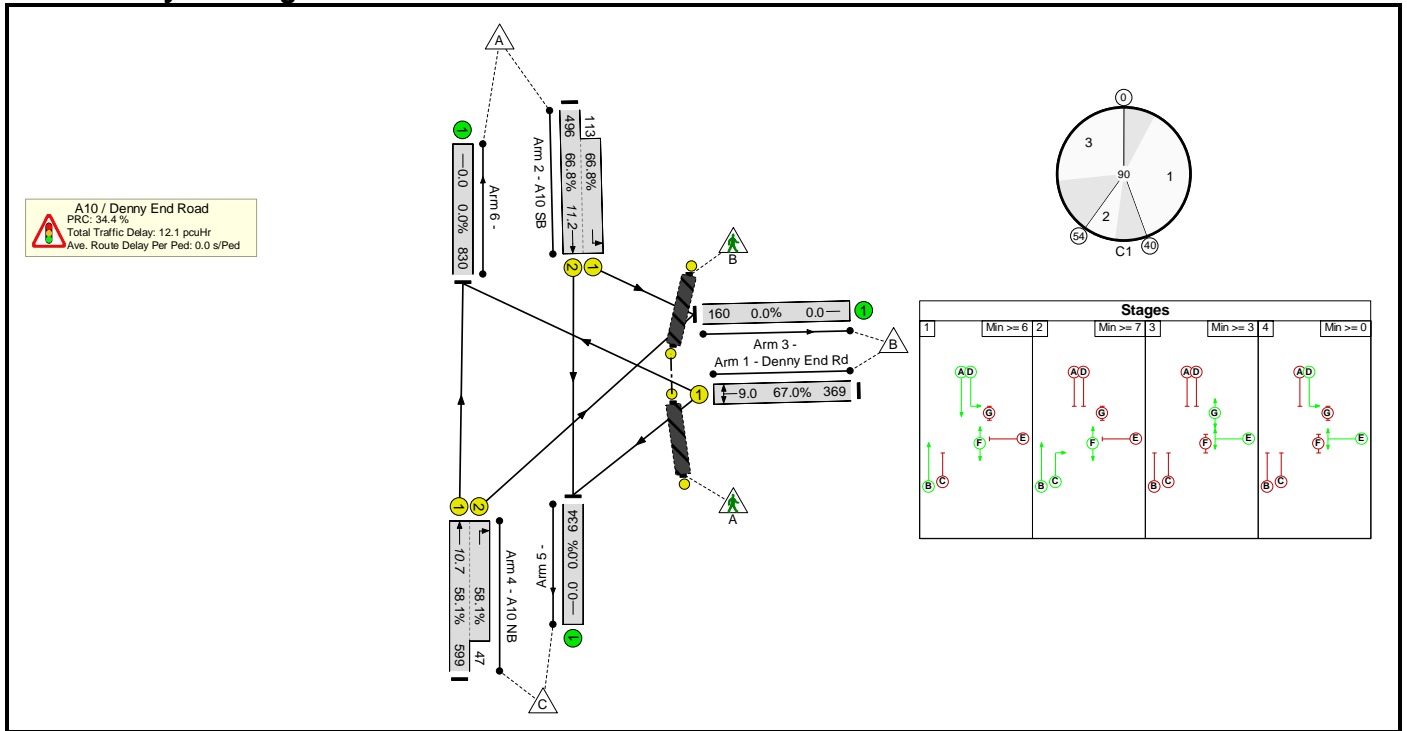

Basic Results Summary

Network Results

Item	Lane Description	Lane Type	Full Phase	Arrow Phase	Num Greens	Total Green (s)	Arrow Green (s)	Demand Flow (pcu)	Sat Flow (pcu/Hr)	Capacity (pcu)	Deg Sat (%)	Turners In Gaps (pcu)	Turners When Unopposed (pcu)	Turners In Intergreen (pcu)	Total Delay (pcuHr)	Av. Delay Per PCU (s/pcu)	Mean Max Queue (pcu)	
Network: AWS Cambridge WWTPRP EIA Stage 2	-	-	-		-	-	-	-	-	-	67.0%	0	0	0	12.1	-	-	
A10 / Denny End Road	-	-	-		-	-	-	-	-	-	67.0%	0	0	0	12.1	-	-	
1/1	Denny End Rd Left Right	U	E		1	27	-	369	1771	551	67.0%	-	-	-	3.8	36.8	9.0	
2/2+2/1	A10 SB Left Ahead	U	A D		1	33	-	609	1965:1774	742+169	66.8 : 66.8%	-	-	-	4.8	28.3	11.2	
4/1+4/2	A10 NB Right Ahead	U	B C		1	47:7	-	646	1940:1842	1031+81	58.1 : 58.1%	-	-	-	3.6	19.8	10.7	
Ped Link: P1	Unnamed Ped Link	-	F		1	47	-	0	-	37600	0.0%	-	-	-	0.0	0.0	0.0	
Ped Link: P2	Unnamed Ped Link	-	G		1	24	-	0	-	19200	0.0%	-	-	-	0.0	0.0	0.0	
C1					PRC for Signalled Lanes (%):		34.4	Total Delay for Signalled Lanes (pcuHr):			12.12	Cycle Time (s):		90				
					PRC Over All Lanes (%):		34.4	Total Delay Over All Lanes(pcuHr):			12.12							

Basic Results Summary

Scenario 3: '2026 Base AM' (FG3: '2026 Base AM', Plan 1: 'Network Control Plan 1')

Network Layout Diagram

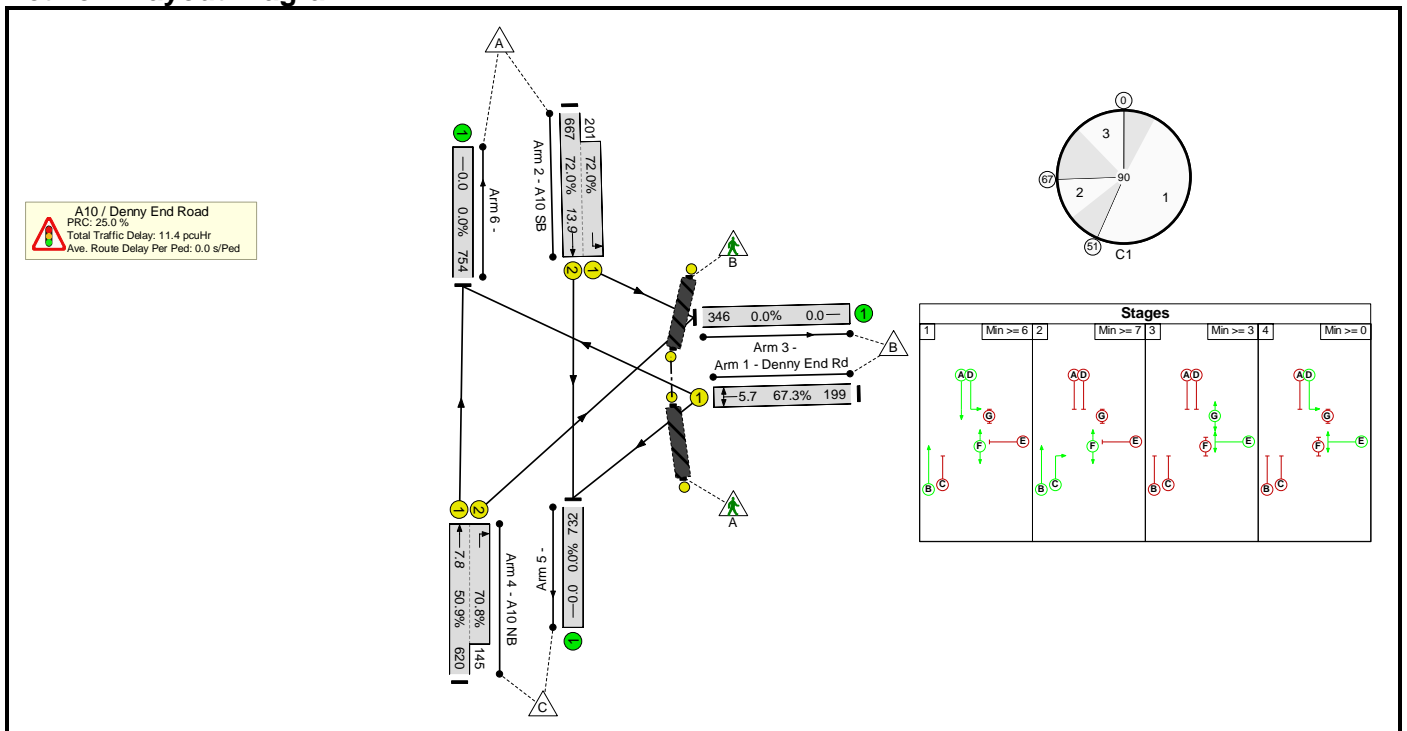

Basic Results Summary

Network Results

Item	Lane Description	Lane Type	Full Phase	Arrow Phase	Num Greens	Total Green (s)	Arrow Green (s)	Demand Flow (pcu)	Sat Flow (pcu/Hr)	Capacity (pcu)	Deg Sat (%)	Turners In Gaps (pcu)	Turners When Unopposed (pcu)	Turners In Intergreen (pcu)	Total Delay (pcuHr)	Av. Delay Per PCU (s/pcu)	Mean Max Queue (pcu)	
Network: AWS Cambridge WWTPRP EIA Stage 2	-	-	-		-	-	-	-	-	-	72.0%	0	0	0	11.4	-	-	
A10 / Denny End Road	-	-	-		-	-	-	-	-	-	72.0%	0	0	0	11.4	-	-	
1/1	Denny End Rd Left Right	U	E		1	14	-	199	1773	295	67.3%	-	-	-	3.0	53.5	5.7	
2/2+2/1	A10 SB Left Ahead	U	A D		1	44	-	868	1965:1774	926+279	72.0 : 72.0%	-	-	-	5.1	21.3	13.9	
4/1+4/2	A10 NB Right Ahead	U	B C		1	60:9	-	765	1940:1842	1219+205	50.9 : 70.8%	-	-	-	3.3	15.6	7.8	
Ped Link: P1	Unnamed Ped Link	-	F		1	60	-	0	-	48000	0.0%	-	-	-	0.0	0.0	0.0	
Ped Link: P2	Unnamed Ped Link	-	G		1	11	-	0	-	8800	0.0%	-	-	-	0.0	0.0	0.0	
C1					PRC for Signalled Lanes (%): 25.0		25.0		Total Delay for Signalled Lanes (pcuHr): 11.41			11.41		Cycle Time (s): 90				
					PRC Over All Lanes (%):		25.0		Total Delay Over All Lanes(pcuHr):			11.41						

Basic Results Summary

Scenario 4: '2026 Base PM' (FG4: '2026 Base PM', Plan 1: 'Network Control Plan 1')

Network Layout Diagram

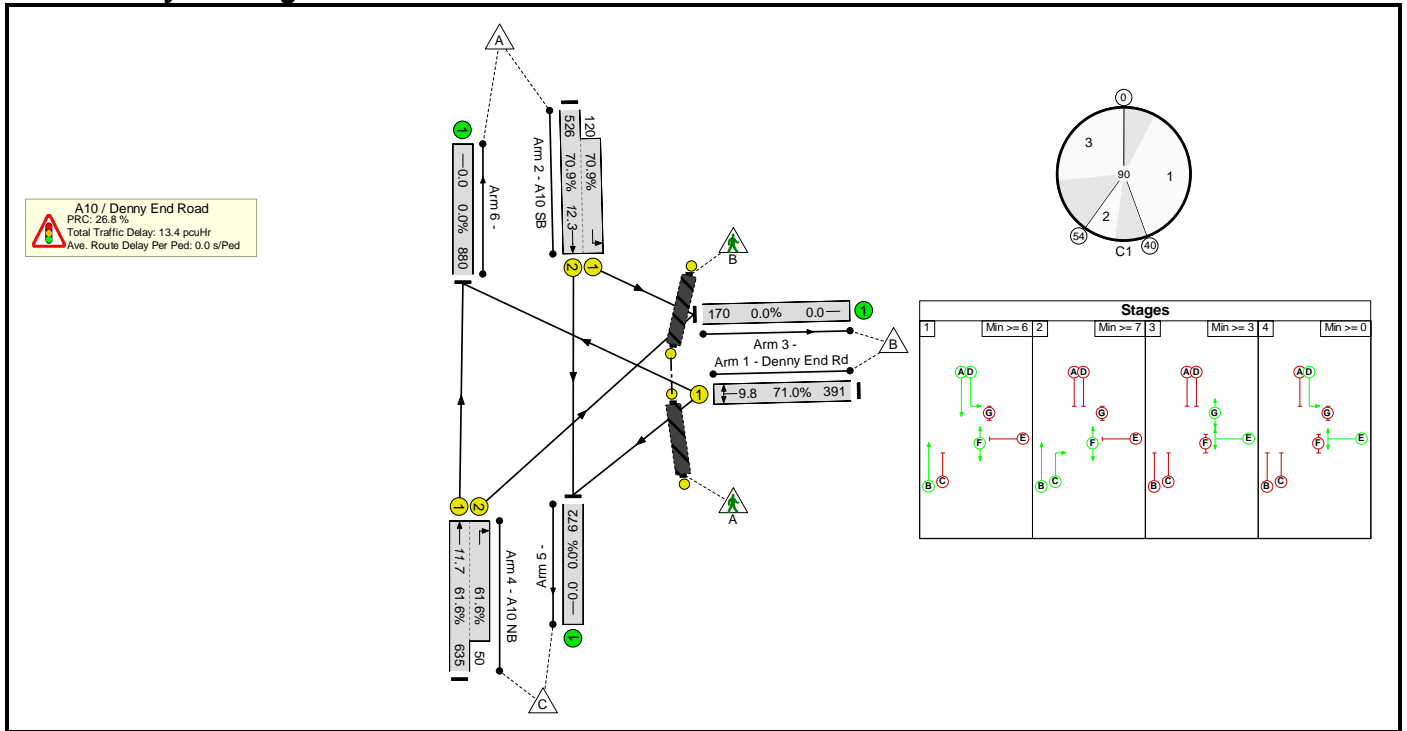

Basic Results Summary

Network Results

Item	Lane Description	Lane Type	Full Phase	Arrow Phase	Num Greens	Total Green (s)	Arrow Green (s)	Demand Flow (pcu)	Sat Flow (pcu/Hr)	Capacity (pcu)	Deg Sat (%)	Turners In Gaps (pcu)	Turners When Unopposed (pcu)	Turners In Intergreen (pcu)	Total Delay (pcuHr)	Av. Delay Per PCU (s/pcu)	Mean Max Queue (pcu)
Network: AWS Cambridge WWTPRP EIA Stage 2	-	-	-		-	-	-	-	-	-	71.0%	0	0	0	13.4	-	-
A10 / Denny End Road	-	-	-		-	-	-	-	-	-	71.0%	0	0	0	13.4	-	-
1/1	Denny End Rd Left Right	U	E		1	27	-	391	1771	551	71.0%	-	-	-	4.2	38.5	9.8
2/2+2/1	A10 SB Left Ahead	U	A D		1	33	-	646	1965:1774	742+169	70.9 : 70.9%	-	-	-	5.3	29.6	12.3
4/1+4/2	A10 NB Right Ahead	U	B C		1	47:7	-	685	1940:1842	1031+81	61.6 : 61.6%	-	-	-	3.9	20.5	11.7
Ped Link: P1	Unnamed Ped Link	-	F		1	47	-	0	-	37600	0.0%	-	-	-	0.0	0.0	0.0
Ped Link: P2	Unnamed Ped Link	-	G		1	24	-	0	-	19200	0.0%	-	-	-	0.0	0.0	0.0
C1					PRC for Signalled Lanes (%):		26.8	Total Delay for Signalled Lanes (pcuHr):			13.39	Cycle Time (s):		90			
					PRC Over All Lanes (%):		26.8	Total Delay Over All Lanes(pcuHr):			13.39						

Basic Results Summary

Scenario 11: '2026 + Construction AM' (FG17: '2026 Base + Construction AM', Plan 1: 'Network Control Plan 1')

Network Layout Diagram

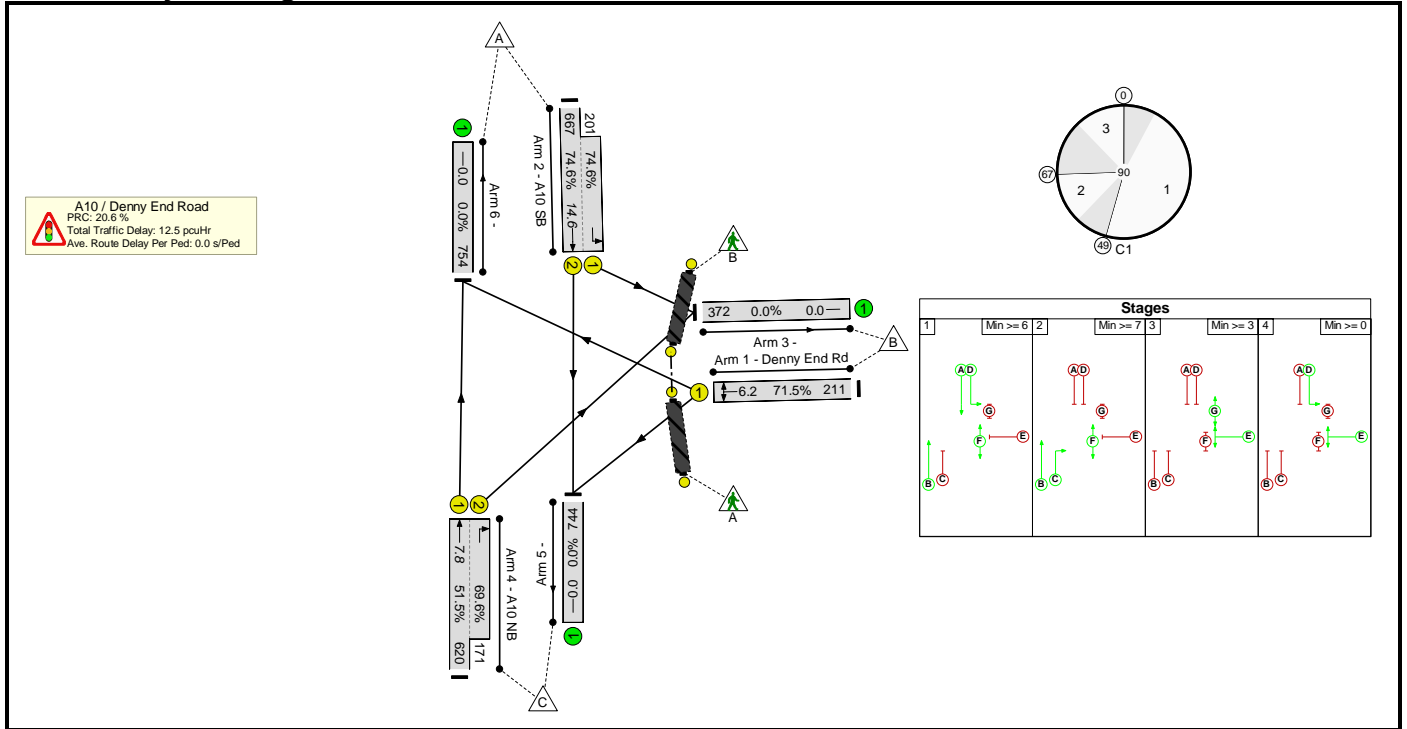

Basic Results Summary

Network Results

Item	Lane Description	Lane Type	Full Phase	Arrow Phase	Num Greens	Total Green (s)	Arrow Green (s)	Demand Flow (pcu)	Sat Flow (pcu/Hr)	Capacity (pcu)	Deg Sat (%)	Turners In Gaps (pcu)	Turners When Unopposed (pcu)	Turners In Intergreen (pcu)	Total Delay (pcuHr)	Av. Delay Per PCU (s/pcu)	Mean Max Queue (pcu)
Network: AWS Cambridge WWTPRP EIA Stage 2	-	-	-		-	-	-	-	-	-	74.6%	0	0	0	12.5	-	-
A10 / Denny End Road	-	-	-		-	-	-	-	-	-	74.6%	0	0	0	12.5	-	-
1/1	Denny End Rd Left Right	U	E		1	14	-	211	1771	295	71.5%	-	-	-	3.3	56.3	6.2
2/2+2/1	A10 SB Left Ahead	U	A D		1	42	-	868	1965:1774	894+269	74.6 : 74.6%	-	-	-	5.7	23.5	14.6
4/1+4/2	A10 NB Right Ahead	U	B C		1	60:11	-	791	1940:1842	1203+246	51.5 : 69.6%	-	-	-	3.6	16.2	7.8
Ped Link: P1	Unnamed Ped Link	-	F		1	60	-	0	-	48000	0.0%	-	-	-	0.0	0.0	0.0
Ped Link: P2	Unnamed Ped Link	-	G		1	11	-	0	-	8800	0.0%	-	-	-	0.0	0.0	0.0
		C1	PRC for Signalled Lanes (%):		20.6		Total Delay for Signalled Lanes (pcuHr):		12.52		Cycle Time (s):		90				
			PRC Over All Lanes (%):		20.6		Total Delay Over All Lanes(pcuHr):		12.52								

Basic Results Summary

Scenario 12: '2026 + Construction PM' (FG18: '2026 Base + Construction PM', Plan 1: 'Network Control Plan 1')

Network Layout Diagram

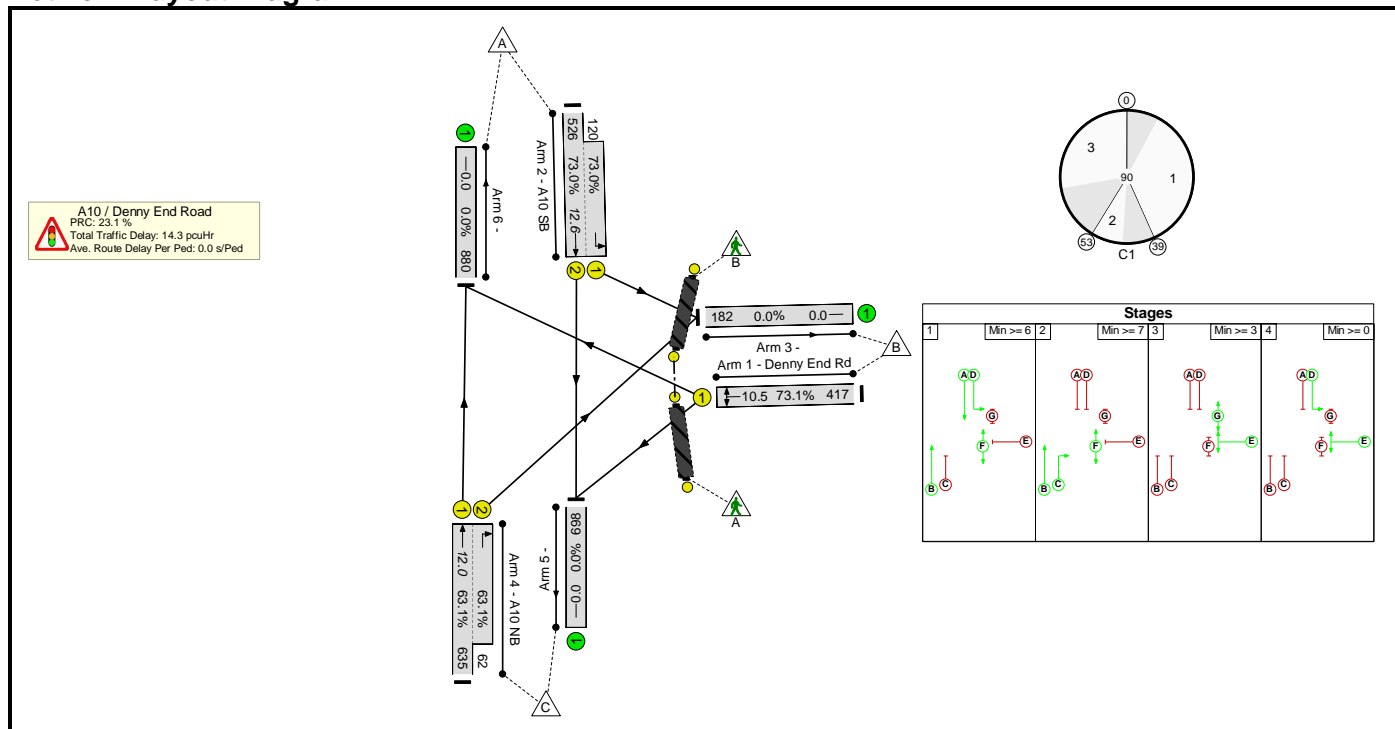

Basic Results Summary

Network Results

Item	Lane Description	Lane Type	Full Phase	Arrow Phase	Num Greens	Total Green (s)	Arrow Green (s)	Demand Flow (pcu)	Sat Flow (pcu/Hr)	Capacity (pcu)	Deg Sat (%)	Turners In Gaps (pcu)	Turners When Unopposed (pcu)	Turners In Intergreen (pcu)	Total Delay (pcuHr)	Av. Delay Per PCU (s/pcu)	Mean Max Queue (pcu)
Network: AWS Cambridge WWTPRP EIA Stage 2	-	-	-		-	-	-	-	-	-	73.1%	0	0	0	14.3	-	-
A10 / Denny End Road	-	-	-		-	-	-	-	-	-	73.1%	0	0	0	14.3	-	-
1/1	Denny End Rd Left Right	U	E		1	28	-	417	1770	570	73.1%	-	-	-	4.5	38.6	10.5
2/2+2/1	A10 SB Left Ahead	U	A D		1	32	-	646	1965:1774	721+164	73.0 : 73.0%	-	-	-	5.6	31.1	12.6
4/1+4/2	A10 NB Right Ahead	U	B C		1	46:7	-	697	1940:1842	1006+98	63.1 : 63.1%	-	-	-	4.2	21.8	12.0
Ped Link: P1	Unnamed Ped Link	-	F		1	46	-	0	-	36800	0.0%	-	-	-	0.0	0.0	0.0
Ped Link: P2	Unnamed Ped Link	-	G		1	25	-	0	-	20000	0.0%	-	-	-	0.0	0.0	0.0
C1					PRC for Signalled Lanes (%):		23.1	Total Delay for Signalled Lanes (pcuHr):			14.26	Cycle Time (s):		90			
					PRC Over All Lanes (%):		23.1	Total Delay Over All Lanes(pcuHr):			14.26						

4 A10 / Car Dyke Road (Junctions 9)

- 2021 Baseline AM
- 2021 Baseline PM
- Construction Year 3 (2026) – Future Baseline AM
- Construction Year 3 (2026) – Future Baseline PM
- Construction Year 3 (2026) – Construction Peak AM
- Construction Year 3 (2026) – Construction Peak PM

Junctions 9

PICADY 9 - Priority Intersection Module

Version: 9.5.0.6896
© Copyright TRL Limited, 2018

For sales and distribution information, program advice and maintenance, contact TRL:
+44 (0)1344 379777 software@trl.co.uk www.trlsoftware.co.uk

The users of this computer program for the solution of an engineering problem are in no way relieved of their responsibility for the correctness of the solution

Filename: A10_Car Dyke Rd.j9

Path: C:\Users\BAS102795\OneDrive - Mott MacDonald\Projects\Camb linsig\Modelling\2_A10_Car Dyke Road

Report generation date: 09/02/2024 15:26:56

- »2021, AM
- »2021, PM
- »2026, AM
- »2026, PM
- »2026 +Cons, AM
- »2026 +Cons, PM

Summary of junction performance

	AM				PM			
	Queue (PCU)	Delay (s)	RFC	LOS	Queue (PCU)	Delay (s)	RFC	LOS
2021								
Stream B-AC	1.3	17.60	0.57	C	0.8	14.67	0.46	B
Stream C-AB	0.5	11.46	0.35	B	0.9	13.18	0.48	B
2026								
Stream B-AC	1.7	21.76	0.64	C	1.1	17.29	0.51	C
Stream C-AB	0.6	12.35	0.38	B	1.1	14.72	0.52	B
2028								
Stream B-AC	1.9	23.50	0.66	C	1.2	18.68	0.54	C
Stream C-AB	0.7	12.82	0.39	B	1.2	15.38	0.54	C
2033								
Stream B-AC	2.5	30.16	0.73	D	1.5	23.02	0.60	C

Stream C-AB	0.8	13.93	0.42	B	1.4	17.22	0.58	C
2038								
Stream B-AC	3.7	43.17	0.80	E	2.0	30.16	0.68	D
Stream C-AB	0.8	15.04	0.45	C	1.6	19.47	0.62	C
2026 +Cons								
Stream B-AC	2.2	25.82	0.68	D	1.4	21.15	0.59	C
Stream C-AB	0.8	14.28	0.44	B	1.3	16.45	0.56	C
2028 + Decommissioning								
Stream B-AC	1.9	23.50	0.66	C	1.2	18.68	0.54	C
Stream C-AB	0.7	12.82	0.39	B	1.2	15.38	0.54	C
2033 + Operation								
Stream B-AC	2.5	30.16	0.73	D	1.5	23.02	0.60	C
Stream C-AB	0.8	13.93	0.42	B	1.4	17.22	0.58	C
2038 + Operation								
Stream B-AC	3.7	43.17	0.80	E	2.0	30.16	0.68	D
Stream C-AB	0.8	15.04	0.45	C	1.6	19.47	0.62	C

Values shown are the highest values encountered over all time segments. Delay is the maximum value of average delay per arriving vehicle.

File summary

File Description

Title	A10_Car Dyke Rd
Location	Cambridge
Site number	
Date	16/03/2022
Version	0.1
Status	(new file)
Identifier	
Client	Anglian Water
Jobnumber	
Enumerator	MOTTMAC\srvc_lond_trans
Description	

Units

Distance units	Speed units	Traffic units input	Traffic units results	Flow units	Average delay units	Total delay units	Rate of delay units
m	kph	PCU	PCU	perHour	s	-Min	perMin

Analysis Options

Calculate Queue Percentiles	Calculate residual capacity	RFC Threshold	Average Delay threshold (s)	Queue threshold (PCU)
		0.85	36.00	20.00

Demand Set Summary

ID	Scenario name	Time Period name	Traffic profile type	Start time (HH:mm)	Finish time (HH:mm)	Time segment length (min)
D1	2021	AM	ONE HOUR	08:00	09:30	15
D2	2021	PM	ONE HOUR	17:00	18:30	15
D3	2026	AM	ONE HOUR	08:00	09:30	15
D4	2026	PM	ONE HOUR	17:00	18:30	15
D5	2028	AM	ONE HOUR	08:00	09:30	15
D6	2028	PM	ONE HOUR	17:00	18:30	15
D7	2033	AM	ONE HOUR	08:00	09:30	15

D8	2033	PM	ONE HOUR	17:00	18:30	15
D9	2038	AM	ONE HOUR	08:00	09:30	15
D10	2038	PM	ONE HOUR	17:00	18:30	15
D11	2026 +Cons	AM	ONE HOUR	08:00	09:30	15
D12	2026 +Cons	PM	ONE HOUR	17:00	18:30	15
D13	2028 + Decommissioning	AM	ONE HOUR	08:00	09:30	15
D14	2028 + Decommissioning	PM	ONE HOUR	17:00	18:30	15
D15	2033 + Operation	AM	ONE HOUR	08:00	09:30	15
D16	2033 + Operation	PM	ONE HOUR	17:00	18:30	15
D17	2038 + Operation	AM	ONE HOUR	08:00	09:30	15
D18	2038 + Operation	PM	ONE HOUR	17:00	18:30	15

Analysis Set Details

ID	Network flow scaling factor (%)
A1	100.000

2021, AM

Data Errors and Warnings

No errors or warnings

Junction Network

Junctions

Junction	Name	Junction type	Major road direction	Use circulating lanes	Junction Delay (s)	Junction LOS
1	A10_Car Dyke Rd	T-Junction	Two-way		3.28	A

Junction Network Options

Driving side	Lighting
Left	Normal/unknown

Arms

Arms

Arm	Name	Description	Arm type
A	Ely Road (N)		Major
B	Car Dyke Road		Minor
C	Ely Road (S)		Major

Major Arm Geometry

Arm	Width of carriageway (m)	Has kerbed central reserve	Width of kerbed central reserve (m)	Has right turn bay	Width for right turn (m)	Visibility for right turn (m)	Blocks?	Blocking queue (PCU)
C	6.00	✓	4.50	✓	3.00	200.0	✓	19.00

Geometries for Arm C are measured opposite Arm B. Geometries for Arm A (if relevant) are measured opposite Arm D.

Minor Arm Geometry

Arm	Minor arm type	Lane width (m)	Visibility to left (m)	Visibility to right (m)
B	One lane	3.50	200	200

Slope / Intercept / Capacity

Priority Intersection Slopes and Intercepts

Junction	Stream	Intercept (PCU/hr)	Slope for A-B	Slope for A-C	Slope for C-A	Slope for C-B
1	B-A	751	0.124	0.314	0.198	0.449
1	B-C	787	0.121	0.305	-	-
1	C-B	750	0.291	0.291	-	-

The slopes and intercepts shown above do NOT include any corrections or adjustments.

Streams may be combined, in which case capacity will be adjusted.

Values are shown for the first time segment only; they may differ for subsequent time segments.

Traffic Demand

Demand Set Details

ID	Scenario name	Time Period name	Traffic profile type	Start time (HH:mm)	Finish time (HH:mm)	Time segment length (min)
D1	2021	AM	ONE HOUR	08:00	09:30	15

Vehicle mix source	PCU Factor for a HV (PCU)
HV Percentages	2.00

Demand overview (Traffic)

Arm	Linked arm	Use O-D data	Average Demand (PCU/hr)	Scaling Factor (%)
A		✓	779	100.000
B		✓	254	100.000
C		✓	883	100.000

Origin-Destination Data

Demand (PCU/hr)

		To		
		A	B	C
From	A	0	71	708
	B	25	0	229
	C	725	158	0

Vehicle Mix

Heavy Vehicle Percentages

		To		
		A	B	C
From	A	0	1	9
	B	14	0	1
	C	10	4	0

Results

Results Summary for whole modelled period

Stream	Max RFC	Max Delay (s)	Max Queue (PCU)	Max LOS
B-AC	0.57	17.60	1.3	C

C-AB	0.35	11.46	0.5	B
C-A				
A-B				
A-C				

Main Results for each time segment

08:00 - 08:15

Stream	Total Demand (PCU/hr)	Capacity (PCU/hr)	RFC	Throughput (PCU/hr)	End queue (PCU)	Delay (s)	Unsignalised level of service
B-AC	191	590	0.324	189	0.5	9.134	A
C-AB	119	579	0.205	118	0.3	8.093	A
C-A	546			546			
A-B	53			53			
A-C	533			533			

08:15 - 08:30

Stream	Total Demand (PCU/hr)	Capacity (PCU/hr)	RFC	Throughput (PCU/hr)	End queue (PCU)	Delay (s)	Unsignalised level of service
B-AC	228	549	0.416	227	0.7	11.396	B
C-AB	142	546	0.260	142	0.4	9.242	A
C-A	652			652			
A-B	64			64			
A-C	636			636			

08:30 - 08:45

Stream	Total Demand (PCU/hr)	Capacity (PCU/hr)	RFC	Throughput (PCU/hr)	End queue (PCU)	Delay (s)	Unsignalised level of service
B-AC	280	488	0.573	277	1.3	17.225	C
C-AB	174	501	0.347	173	0.5	11.408	B
C-A	798			798			
A-B	78			78			
A-C	780			780			

08:45 - 09:00

Stream	Total Demand (PCU/hr)	Capacity (PCU/hr)	RFC	Throughput (PCU/hr)	End queue (PCU)	Delay (s)	Unsignalised level of service
B-AC	280	488	0.573	280	1.3	17.597	C
C-AB	174	501	0.347	174	0.5	11.457	B
C-A	798			798			
A-B	78			78			
A-C	780			780			

09:00 - 09:15

Stream	Total Demand (PCU/hr)	Capacity (PCU/hr)	RFC	Throughput (PCU/hr)	End queue (PCU)	Delay (s)	Unsignalised level of service
B-AC	228	549	0.416	231	0.7	11.638	B
C-AB	142	546	0.260	143	0.4	9.291	A
C-A	652			652			
A-B	64			64			
A-C	636			636			

09:15 - 09:30

Stream	Total Demand (PCU/hr)	Capacity (PCU/hr)	RFC	Throughput (PCU/hr)	End queue (PCU)	Delay (s)	Unsignalised level of service
B-AC	191	590	0.324	192	0.5	9.269	A
C-AB	119	579	0.205	119	0.3	8.143	A
C-A	546			546			
A-B	53			53			
A-C	533			533			

2021, PM

Data Errors and Warnings

No errors or warnings

Junction Network

Junctions

Junction	Name	Junction type	Major road direction	Use circulating lanes	Junction Delay (s)	Junction LOS
1	A10_Car Dyke Rd	T-Junction	Two-way		3.29	A

Junction Network Options

Driving side	Lighting
Left	Normal/unknown

Traffic Demand

Demand Set Details

ID	Scenario name	Time Period name	Traffic profile type	Start time (HH:mm)	Finish time (HH:mm)	Time segment length (min)
D2	2021	PM	ONE HOUR	17:00	18:30	15

Vehicle mix source	PCU Factor for a HV (PCU)
HV Percentages	2.00

Demand overview (Traffic)

Arm	Linked arm	Use O-D data	Average Demand (PCU/hr)	Scaling Factor (%)
A		✓	696	100.000
B		✓	192	100.000
C		✓	894	100.000

Origin-Destination Data

Demand (PCU/hr)

		To		
		A	B	C
From	A	0	40	656
	B	36	0	156
	C	663	231	0

Vehicle Mix

Heavy Vehicle Percentages

From	To		
	A	B	C
A	0	3	5
B	0	0	2
C	4	0	0

Results

Results Summary for whole modelled period

Stream	Max RFC	Max Delay (s)	Max Queue (PCU)	Max LOS
B-AC	0.46	14.67	0.8	B
C-AB	0.48	13.18	0.9	B
C-A				
A-B				
A-C				

Main Results for each time segment

17:00 - 17:15

Stream	Total Demand (PCU/hr)	Capacity (PCU/hr)	RFC	Throughput (PCU/hr)	End queue (PCU)	Delay (s)	Unsignalised level of service
B-AC	145	576	0.251	143	0.3	8.415	A
C-AB	174	598	0.291	172	0.4	8.433	A
C-A	499			499			
A-B	30			30			
A-C	494			494			

17:15 - 17:30

Stream	Total Demand (PCU/hr)	Capacity (PCU/hr)	RFC	Throughput (PCU/hr)	End queue (PCU)	Delay (s)	Unsignalised level of service
B-AC	173	531	0.325	172	0.5	10.173	B
C-AB	208	568	0.366	207	0.6	9.953	A
C-A	596			596			
A-B	36			36			
A-C	590			590			

17:30 - 17:45

Stream	Total Demand (PCU/hr)	Capacity (PCU/hr)	RFC	Throughput (PCU/hr)	End queue (PCU)	Delay (s)	Unsignalised level of service
B-AC	211	461	0.459	210	0.8	14.492	B
C-AB	254	527	0.482	253	0.9	13.060	B
C-A	730			730			
A-B	44			44			
A-C	722			722			

17:45 - 18:00

Stream	Total Demand (PCU/hr)	Capacity (PCU/hr)	RFC	Throughput (PCU/hr)	End queue (PCU)	Delay (s)	Unsignalised level of service
B-AC							
C-AB							
C-A							
A-B							
A-C							

B-AC	211	461	0.459	211	0.8	14.675	B
C-AB	254	527	0.482	254	0.9	13.184	B
C-A	730			730			
A-B	44			44			
A-C	722			722			

18:00 - 18:15

Stream	Total Demand (PCU/hr)	Capacity (PCU/hr)	RFC	Throughput (PCU/hr)	End queue (PCU)	Delay (s)	Unsignalised level of service
B-AC	173	531	0.325	174	0.5	10.299	B
C-AB	208	568	0.366	209	0.6	10.064	B
C-A	596			596			
A-B	36			36			
A-C	590			590			

18:15 - 18:30

Stream	Total Demand (PCU/hr)	Capacity (PCU/hr)	RFC	Throughput (PCU/hr)	End queue (PCU)	Delay (s)	Unsignalised level of service
B-AC	145	576	0.251	145	0.3	8.500	A
C-AB	174	598	0.291	175	0.4	8.523	A
C-A	499			499			
A-B	30			30			
A-C	494			494			

2026 , AM

Data Errors and Warnings

No errors or warnings

Junction Network

Junctions

Junction	Name	Junction type	Major road direction	Use circulating lanes	Junction Delay (s)	Junction LOS
1	A10_Car Dyke Rd	T-Junction	Two-way		3.91	A

Junction Network Options

Driving side	Lighting
Left	Normal/unknown

Traffic Demand

Demand Set Details

ID	Scenario name	Time Period name	Traffic profile type	Start time (HH:mm)	Finish time (HH:mm)	Time segment length (min)
D3	2026	AM	ONE HOUR	08:00	09:30	15

Vehicle mix source	PCU Factor for a HV (PCU)
HV Percentages	2.00

Demand overview (Traffic)

Arm	Linked arm	Use O-D data	Average Demand (PCU/hr)	Scaling Factor (%)
A		✓	825	100.000

B		✓	270	100.000
C		✓	936	100.000

Origin-Destination Data

Demand (PCU/hr)

		To		
		A	B	C
From	A	0	75	750
	B	27	0	243
	C	769	167	0

Vehicle Mix

Heavy Vehicle Percentages

		To		
		A	B	C
From	A	0	1	9
	B	13	0	1
	C	10	4	0

Results

Results Summary for whole modelled period

Stream	Max RFC	Max Delay (s)	Max Queue (PCU)	Max LOS
B-AC	0.64	21.76	1.7	C
C-AB	0.38	12.35	0.6	B
C-A				
A-B				
A-C				

Main Results for each time segment

08:00 - 08:15

Stream	Total Demand (PCU/hr)	Capacity (PCU/hr)	RFC	Throughput (PCU/hr)	End queue (PCU)	Delay (s)	Unsignalised level of service
B-AC	203	577	0.352	201	0.5	9.737	A
C-AB	126	569	0.221	125	0.3	8.369	A
C-A	579			579			
A-B	56			56			
A-C	565			565			

08:15 - 08:30

Stream	Total Demand (PCU/hr)	Capacity (PCU/hr)	RFC	Throughput (PCU/hr)	End queue (PCU)	Delay (s)	Unsignalised level of service
B-AC	243	533	0.455	242	0.8	12.582	B

C-AB	150	534	0.281	150	0.4	9.692	A
C-A	691			691			
A-B	67			67			
A-C	674			674			

08:30 - 08:45

Stream	Total Demand (PCU/hr)	Capacity (PCU/hr)	RFC	Throughput (PCU/hr)	End queue (PCU)	Delay (s)	Unsignalised level of service
B-AC	297	466	0.638	294	1.7	20.984	C
C-AB	184	486	0.378	183	0.6	12.286	B
C-A	847			847			
A-B	83			83			
A-C	826			826			

08:45 - 09:00

Stream	Total Demand (PCU/hr)	Capacity (PCU/hr)	RFC	Throughput (PCU/hr)	End queue (PCU)	Delay (s)	Unsignalised level of service
B-AC	297	466	0.638	297	1.7	21.761	C
C-AB	184	486	0.378	184	0.6	12.353	B
C-A	847			847			
A-B	83			83			
A-C	826			826			

09:00 - 09:15

Stream	Total Demand (PCU/hr)	Capacity (PCU/hr)	RFC	Throughput (PCU/hr)	End queue (PCU)	Delay (s)	Unsignalised level of service
B-AC	243	533	0.455	246	0.9	12.997	B
C-AB	150	534	0.281	151	0.4	9.756	A
C-A	691			691			
A-B	67			67			
A-C	674			674			

09:15 - 09:30

Stream	Total Demand (PCU/hr)	Capacity (PCU/hr)	RFC	Throughput (PCU/hr)	End queue (PCU)	Delay (s)	Unsignalised level of service
B-AC	203	577	0.352	205	0.6	9.918	A
C-AB	126	569	0.221	126	0.3	8.429	A
C-A	579			579			
A-B	56			56			
A-C	565			565			

2026, PM

Data Errors and Warnings

No errors or warnings

Junction Network

Junctions

Junction	Name	Junction type	Major road direction	Use circulating lanes	Junction Delay (s)	Junction LOS
1	A10_Car Dyke Rd	T-Junction	Two-way		3.77	A

Junction Network Options

Driving side	Lighting
--------------	----------

Left	Normal/unknown
------	----------------

Traffic Demand

Demand Set Details

ID	Scenario name	Time Period name	Traffic profile type	Start time (HH:mm)	Finish time (HH:mm)	Time segment length (min)
D4	2026	PM	ONE HOUR	17:00	18:30	15

Vehicle mix source	PCU Factor for a HV (PCU)
HV Percentages	2.00

Demand overview (Traffic)

Arm	Linked arm	Use O-D data	Average Demand (PCU/hr)	Scaling Factor (%)
A		✓	737	100.000
B		✓	203	100.000
C		✓	948	100.000

Origin-Destination Data

Demand (PCU/hr)

	To			
	A	B	C	
From	A	0	42	695
	B	38	0	165
	C	703	245	0

Vehicle Mix

Heavy Vehicle Percentages

	To			
	A	B	C	
From	A	0	2	5
	B	0	0	2
	C	4	0	0

Results

Results Summary for whole modelled period

Stream	Max RFC	Max Delay (s)	Max Queue (PCU)	Max LOS
B-AC	0.51	17.29	1.1	C
C-AB	0.52	14.72	1.1	B
C-A				
A-B				
A-C				

Main Results for each time segment

17:00 - 17:15

Stream	Total Demand (PCU/hr)	Capacity (PCU/hr)	RFC	Throughput (PCU/hr)	End queue (PCU)	Delay (s)	Unsignalised level of service
B-AC	153	563	0.271	151	0.4	8.855	A
C-AB	184	589	0.313	183	0.4	8.829	A
C-A	529			529			
A-B	32			32			
A-C	523			523			

17:15 - 17:30

Stream	Total Demand (PCU/hr)	Capacity (PCU/hr)	RFC	Throughput (PCU/hr)	End queue (PCU)	Delay (s)	Unsignalised level of service
B-AC	182	513	0.355	182	0.6	11.005	B
C-AB	220	557	0.395	219	0.6	10.630	B
C-A	632			632			
A-B	38			38			
A-C	625			625			

17:30 - 17:45

Stream	Total Demand (PCU/hr)	Capacity (PCU/hr)	RFC	Throughput (PCU/hr)	End queue (PCU)	Delay (s)	Unsignalised level of service
B-AC	224	435	0.513	222	1.0	16.962	C
C-AB	270	514	0.525	268	1.1	14.528	B
C-A	774			774			
A-B	46			46			
A-C	765			765			

17:45 - 18:00

Stream	Total Demand (PCU/hr)	Capacity (PCU/hr)	RFC	Throughput (PCU/hr)	End queue (PCU)	Delay (s)	Unsignalised level of service
B-AC	224	435	0.514	223	1.1	17.291	C
C-AB	270	514	0.525	270	1.1	14.717	B
C-A	774			774			
A-B	46			46			
A-C	765			765			

18:00 - 18:15

Stream	Total Demand (PCU/hr)	Capacity (PCU/hr)	RFC	Throughput (PCU/hr)	End queue (PCU)	Delay (s)	Unsignalised level of service
B-AC	182	513	0.356	184	0.6	11.201	B
C-AB	220	557	0.395	222	0.7	10.787	B
C-A	632			632			
A-B	38			38			
A-C	625			625			

18:15 - 18:30

Stream	Total Demand (PCU/hr)	Capacity (PCU/hr)	RFC	Throughput (PCU/hr)	End queue (PCU)	Delay (s)	Unsignalised level of service
B-AC	153	563	0.272	154	0.4	8.961	A
C-AB	184	589	0.313	185	0.5	8.942	A
C-A	529			529			
A-B	32			32			
A-C	523			523			

Stream	Total Demand (PCU/hr)	Capacity (PCU/hr)	RFC	Throughput (PCU/hr)	End queue (PCU)	Delay (s)	Unsignalised level of service
B-AC	205	473	0.433	204	0.8	13.513	B
C-AB	246	534	0.461	245	0.8	12.401	B
C-A	707			707			
A-B	42			42			
A-C	699			699			

17:30 - 17:45

Stream	Total Demand (PCU/hr)	Capacity (PCU/hr)	RFC	Throughput (PCU/hr)	End queue (PCU)	Delay (s)	Unsignalised level of service
B-AC	251	372	0.674	246	1.9	28.092	D
C-AB	302	486	0.621	299	1.6	18.939	C
C-A	865			865			
A-B	52			52			
A-C	857			857			

17:45 - 18:00

Stream	Total Demand (PCU/hr)	Capacity (PCU/hr)	RFC	Throughput (PCU/hr)	End queue (PCU)	Delay (s)	Unsignalised level of service
B-AC	251	371	0.677	251	2.0	30.155	D
C-AB	302	486	0.621	302	1.6	19.471	C
C-A	865			865			
A-B	52			52			
A-C	857			857			

18:00 - 18:15

Stream	Total Demand (PCU/hr)	Capacity (PCU/hr)	RFC	Throughput (PCU/hr)	End queue (PCU)	Delay (s)	Unsignalised level of service
B-AC	205	472	0.434	210	0.8	14.179	B
C-AB	246	534	0.461	249	0.9	12.745	B
C-A	707			707			
A-B	42			42			
A-C	699			699			

18:15 - 18:30

Stream	Total Demand (PCU/hr)	Capacity (PCU/hr)	RFC	Throughput (PCU/hr)	End queue (PCU)	Delay (s)	Unsignalised level of service
B-AC	172	532	0.323	173	0.5	10.216	B
C-AB	206	569	0.362	207	0.6	9.979	A
C-A	592			592			
A-B	35			35			
A-C	586			586			

2026 +Cons, AM

Data Errors and Warnings

No errors or warnings

Junction Network

Junctions

Junction	Name	Junction type	Major road direction	Use circulating lanes	Junction Delay (s)	Junction LOS
1	A10_Car Dyke Rd	T-Junction	Two-way		4.76	A

Junction Network Options

Driving side	Lighting
Left	Normal/unknown

Traffic Demand

Demand Set Details

ID	Scenario name	Time Period name	Traffic profile type	Start time (HH:mm)	Finish time (HH:mm)	Time segment length (min)
D11	2026 +Cons	AM	ONE HOUR	08:00	09:30	15

Vehicle mix source	PCU Factor for a HV (PCU)
HV Percentages	2.00

Demand overview (Traffic)

Arm	Linked arm	Use O-D data	Average Demand (PCU/hr)	Scaling Factor (%)
A		✓	837	100.000
B		✓	282	100.000
C		✓	988	100.000

Origin-Destination Data

Demand (PCU/hr)

		To		
		A	B	C
From	A	0	75	762
	B	27	0	255
	C	795	193	0

Vehicle Mix

Heavy Vehicle Percentages

		To		
		A	B	C
From	A	0	1	10
	B	13	0	4
	C	11	7	0

Results

Results Summary for whole modelled period

Stream	Max RFC	Max Delay (s)	Max Queue (PCU)	Max LOS
B-AC	0.68	25.82	2.2	D
C-AB	0.44	14.28	0.8	B
C-A				
A-B				
A-C				

Main Results for each time segment

08:00 - 08:15

Stream	Total Demand (PCU/hr)	Capacity (PCU/hr)	RFC	Throughput (PCU/hr)	End queue (PCU)	Delay (s)	Unsignalised level of service
B-AC	212	573	0.370	210	0.6	10.322	B
C-AB	145	567	0.256	144	0.4	9.078	A
C-A	599			599			
A-B	56			56			
A-C	574			574			

08:15 - 08:30

Stream	Total Demand (PCU/hr)	Capacity (PCU/hr)	RFC	Throughput (PCU/hr)	End queue (PCU)	Delay (s)	Unsignalised level of service
B-AC	254	527	0.481	252	0.9	13.647	B
C-AB	174	531	0.327	173	0.5	10.731	B
C-A	715			715			
A-B	67			67			
A-C	685			685			

08:30 - 08:45

Stream	Total Demand (PCU/hr)	Capacity (PCU/hr)	RFC	Throughput (PCU/hr)	End queue (PCU)	Delay (s)	Unsignalised level of service
B-AC	310	456	0.681	306	2.1	24.492	C
C-AB	212	482	0.441	211	0.8	14.155	B
C-A	875			875			
A-B	83			83			
A-C	839			839			

08:45 - 09:00

Stream	Total Demand (PCU/hr)	Capacity (PCU/hr)	RFC	Throughput (PCU/hr)	End queue (PCU)	Delay (s)	Unsignalised level of service
B-AC	310	455	0.682	310	2.2	25.822	D
C-AB	212	482	0.441	212	0.8	14.278	B
C-A	875			875			
A-B	83			83			
A-C	839			839			

09:00 - 09:15

Stream	Total Demand (PCU/hr)	Capacity (PCU/hr)	RFC	Throughput (PCU/hr)	End queue (PCU)	Delay (s)	Unsignalised level of service
B-AC	254	527	0.481	258	1.0	14.263	B
C-AB	174	531	0.327	175	0.5	10.840	B
C-A	715			715			
A-B	67			67			
A-C	685			685			

09:15 - 09:30

Stream	Total Demand (PCU/hr)	Capacity (PCU/hr)	RFC	Throughput (PCU/hr)	End queue (PCU)	Delay (s)	Unsignalised level of service
B-AC	212	573	0.371	214	0.6	10.551	B
C-AB	145	567	0.256	146	0.4	9.167	A

C-A	599			599			
A-B	56			56			
A-C	574			574			

2026 +Cons, PM

Data Errors and Warnings

No errors or warnings

Junction Network

Junctions

Junction	Name	Junction type	Major road direction	Use circulating lanes	Junction Delay (s)	Junction LOS
1	A10_Car Dyke Rd	T-Junction	Two-way		4.62	A

Junction Network Options

Driving side	Lighting
Left	Normal/unknown

Traffic Demand

Demand Set Details

ID	Scenario name	Time Period name	Traffic profile type	Start time (HH:mm)	Finish time (HH:mm)	Time segment length (min)
D12	2026 +Cons	PM	ONE HOUR	17:00	18:30	15

Vehicle mix source	PCU Factor for a HV (PCU)
HV Percentages	2.00

Demand overview (Traffic)

Arm	Linked arm	Use O-D data	Average Demand (PCU/hr)	Scaling Factor (%)
A		✓	763	100.000
B		✓	229	100.000
C		✓	972	100.000

Origin-Destination Data

Demand (PCU/hr)

		To		
		A	B	C
From	A	0	42	721
	B	38	0	191
	C	715	257	0

Vehicle Mix

Heavy Vehicle Percentages

From	To		
	A	B	C
A	0	2	6
B	0	0	5
C	4	2	0

Results

Results Summary for whole modelled period

Stream	Max RFC	Max Delay (s)	Max Queue (PCU)	Max LOS
B-AC	0.59	21.15	1.4	C
C-AB	0.56	16.45	1.3	C
C-A				
A-B				
A-C				

Main Results for each time segment

17:00 - 17:15

Stream	Total Demand (PCU/hr)	Capacity (PCU/hr)	RFC	Throughput (PCU/hr)	End queue (PCU)	Delay (s)	Unsignalised level of service
B-AC	172	561	0.307	171	0.5	9.560	A
C-AB	193	583	0.332	191	0.5	9.333	A
C-A	538			538			
A-B	32			32			
A-C	543			543			

17:15 - 17:30

Stream	Total Demand (PCU/hr)	Capacity (PCU/hr)	RFC	Throughput (PCU/hr)	End queue (PCU)	Delay (s)	Unsignalised level of service
B-AC	206	510	0.403	205	0.7	12.231	B
C-AB	231	551	0.420	230	0.7	11.426	B
C-A	643			643			
A-B	38			38			
A-C	648			648			

17:30 - 17:45

Stream	Total Demand (PCU/hr)	Capacity (PCU/hr)	RFC	Throughput (PCU/hr)	End queue (PCU)	Delay (s)	Unsignalised level of service
B-AC	252	429	0.587	249	1.4	20.479	C
C-AB	283	506	0.559	281	1.2	16.171	C
C-A	787			787			
A-B	46			46			
A-C	794			794			

17:45 - 18:00

Stream	Total Demand (PCU/hr)	Capacity (PCU/hr)	RFC	Throughput (PCU/hr)	End queue (PCU)	Delay (s)	Unsignalised level of service
B-AC							
C-AB							
C-A							
A-B							
A-C							

B-AC	252	429	0.588	252	1.4	21.146	C
C-AB	283	506	0.559	283	1.3	16.453	C
C-A	787			787			
A-B	46			46			
A-C	794			794			

18:00 - 18:15

Stream	Total Demand (PCU/hr)	Capacity (PCU/hr)	RFC	Throughput (PCU/hr)	End queue (PCU)	Delay (s)	Unsignalised level of service
B-AC	206	510	0.404	209	0.7	12.567	B
C-AB	231	551	0.420	233	0.8	11.642	B
C-A	643			643			
A-B	38			38			
A-C	648			648			

18:15 - 18:30

Stream	Total Demand (PCU/hr)	Capacity (PCU/hr)	RFC	Throughput (PCU/hr)	End queue (PCU)	Delay (s)	Unsignalised level of service
B-AC	172	561	0.308	173	0.5	9.710	A
C-AB	193	583	0.332	194	0.5	9.476	A
C-A	538			538			
A-B	32			32			
A-C	543			543			

5 Junction 33 - Milton Interchange (LinSig)

- 2021 Baseline AM
- 2021 Baseline PM
- Construction Year 3 (2026) – Future Baseline AM
- Construction Year 3 (2026) – Future Baseline PM
- Construction Year 5 (2028) – Future Baseline AM
- Construction Year 5 (2028) – Future Baseline PM
- Operation Year 1 + 5 (2033) – Future Baseline AM
- Operation Year 1 + 5 (2033) – Future Baseline PM
- Operation Year 1 + 10 (2038) – Future Baseline AM
- Operation Year 1 + 10 (2038) – Future Baseline PM
- Construction Year 3 (2026) – Construction Peak AM
- Construction Year 3 (2026) – Construction Peak PM
- Construction Year 5 (2028) – Decommissioning AM
- Construction Year 5 (2028) – Decommissioning PM
- Operation Year 1 + 5 (2033) – Operation AM
- Operation Year 1 + 5 (2033) – Operation PM
- Operation Year 1 + 10 (2038) – Operation AM
- Operation Year 1 + 10 (2038) – Operation PM

Basic Results Summary
Basic Results Summary

User and Project Details

Project:	100102041 - AWS Cambridge WWTPRP
Title:	Milton Interchange
Location:	Milton Interchange
Client:	Anglian Water
Date Completed:	19.03.24
Flow Details:	https://mottmac.sharepoint.com/teams/pj-d2780/do/Develop/06%20-%20Technical%20Disciplines/12%20-%20Transport/13%20%20Documents%20for%20Independent%20Review/1%20Traffic%20flow/Flow%20Diagrams/WIP/Cambridge%20WWTP_Traffic%20Flow%20Diagrams_v3.xlsx?web=1
Checked By:	GW
Additional detail:	
File name:	Milton Interchange (wit 2038 baselines) HE Scheme_Rev 4_CCC-edits+PBA Edits -1900 SAT Flow_v3.lsg3x
Author:	CD
Company:	Mott MacDonald
Address:	

Basic Results Summary

Scenario 1: '2021 Base AM (Survey)' (FG1: '2021 Base AM (Survey)', Plan 1: 'Network Control Plan 1')

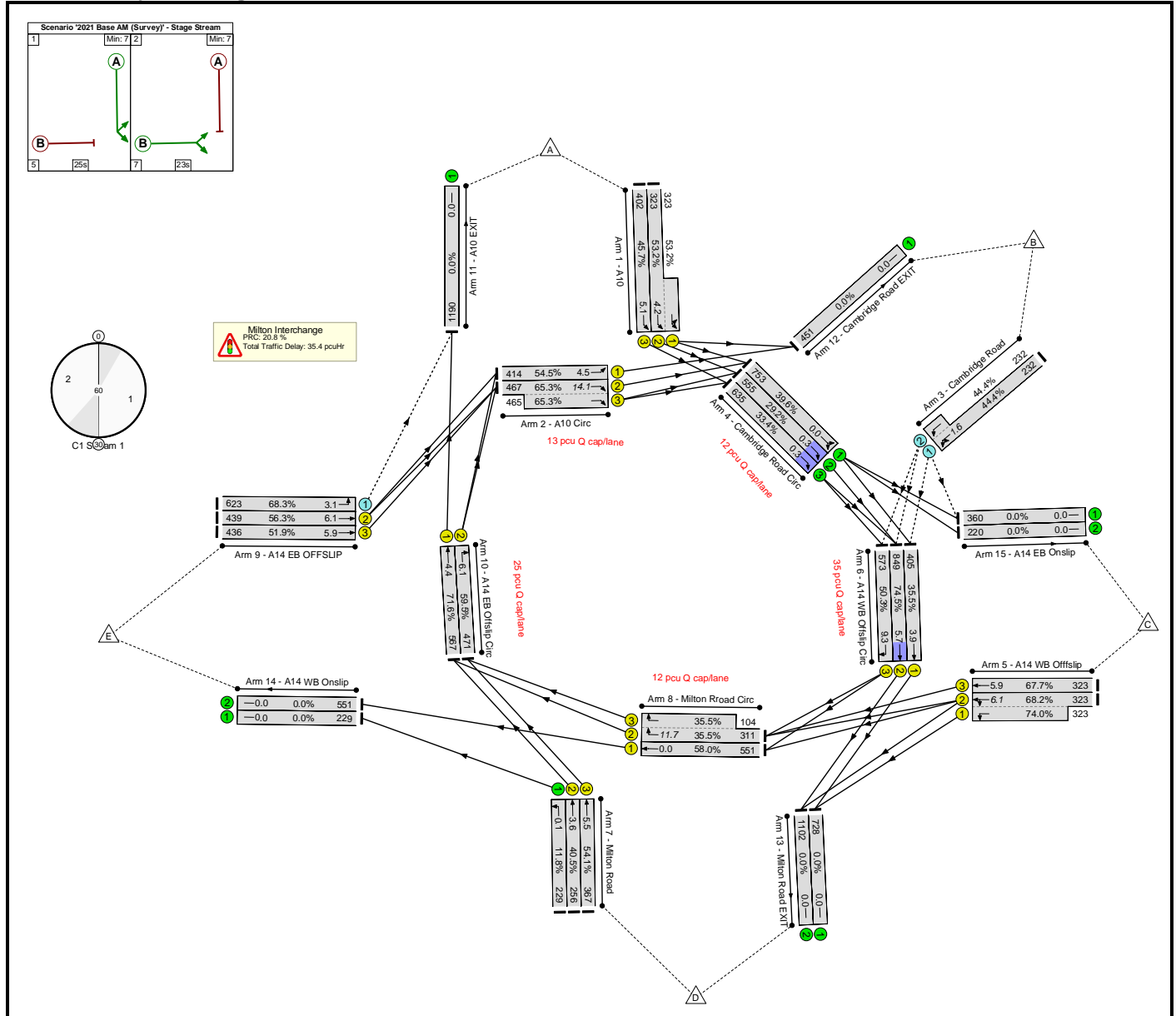

Basic Results Summary

Network Results

Item	Lane Description	Lane Type	Full Phase	Arrow Phase	Num Greens	Total Green (s)	Arrow Green (s)	Demand Flow (pcu)	Sat Flow (pcu/Hr)	Capacity (pcu)	Deg Sat (%)	Turners In Gaps (pcu)	Turners When Unopposed (pcu)	Turners In Intergreen (pcu)	Total Delay (pcuHr)	Av. Delay Per PCU (s/pcu)	Mean Max Queue (pcu)	Item
Network: Milton Interchange	-	-	-		-	-	-	-	-	-	74.5%	1168	383	0	35.4	-	-	Network: Milton Interchange
Milton Interchange	-	-	-		-	-	-	-	-	-	74.5%	1168	383	0	35.4	-	-	Milton Interchange
1/2+1/1	A10 Ahead Left	U	A		1	25	-	646	2057:1910	607+607	53.2 : 53.2%	-	-	-	2.6	14.7	4.2	1/2+1/1
1/3	A10 Ahead	U	A		1	25	-	402	2029	879	45.7%	-	-	-	1.8	15.8	5.1	1/3
2/1	A10 Circ Ahead	U	B		1	23	-	414	1900	760	54.5%	-	-	-	1.3	11.6	4.5	2/1
2/2+2/3	A10 Circ Right	U	B		1	23	-	932	1900:1900	715+712	65.3 : 65.3%	-	-	-	5.2	20.0	14.1	2/2+2/3
3/1+3/2	Cambridge Road Left U-Turn	O	-		-	-	-	464	1828:1986	522+522	44.4 : 44.4%	928	0	0	0.6	4.7	1.6	3/1+3/2
4/1	Cambridge Road Circ Ahead Left	U	-		-	-	-	753	1900	1900	39.6%	-	-	-	0.0	0.0	0.0	4/1
4/2	Cambridge Road Circ Ahead	U	-		-	-	-	555	1900	1900	29.2%	-	-	-	0.0	0.1	0.3	4/2
4/3	Cambridge Road Circ Ahead	U	-		-	-	-	635	1900	1900	33.4%	-	-	-	0.0	0.1	0.3	4/3
5/2+5/1	A14 WB Offslip Ahead Left	U	C		1	13	-	646	2029:1871	473+437	68.2 : 74.0%	-	-	-	5.0	27.9	6.1	5/2+5/1
5/3	A14 WB Offslip Ahead	U	C		1	13	-	323	2044	477	67.7%	-	-	-	2.9	32.5	5.9	5/3
6/1	A14 WB Offslip Circ Ahead	U	D		1	35	-	405	1900	1140	35.5%	-	-	-	0.3	2.7	3.9	6/1
6/2	A14 WB Offslip Circ Ahead	U	D		1	35	-	849	1900	1140	74.5%	-	-	-	1.0	4.4	5.7	6/2

Basic Results Summary

6/3	A14 WB Offslip Circ Right	U	D		1	35	-	573	1900	1140	50.3%	-	-	-	1.9	12.1	9.3	6/3
7/1	Milton Road Left	U	-		-	-	-	229	1946	1946	11.8%	-	-	-	0.1	1.0	0.1	7/1
7/2	Milton Road Ahead	U	E		1	19	-	256	1894	631	40.5%	-	-	-	1.4	20.2	3.6	7/2
7/3	Milton Road Ahead	U	E		1	19	-	367	2037	679	54.1%	-	-	-	2.2	22.0	5.5	7/3
8/1	Milton Road Circ Ahead	U	F		1	29	-	551	1900	950	58.0%	-	-	-	0.0	0.0	0.0	8/1
8/2+8/3	Milton Road Circ Right	U	F		1	29	-	415	1900:1900	877+293	35.5 : 35.5%	-	-	-	1.5	13.2	11.7	8/2+8/3
9/1	A14 EB OFFSLIP Left	O	-		-	-	-	623	1894	913	68.3%	240	383	0	1.1	6.6	3.1	9/1
9/2	A14 EB OFFSLIP Ahead	U	G		1	24	-	439	1871	780	56.3%	-	-	-	2.3	18.6	6.1	9/2
9/3	A14 EB OFFSLIP Ahead	U	G		1	24	-	436	2018	841	51.9%	-	-	-	2.1	17.5	5.9	9/3
10/1	A14 EB Offslip Circ Ahead	U	H		1	24	-	567	1900	792	71.6%	-	-	-	0.8	5.0	4.4	10/1
10/2	A14 EB Offslip Circ Right	U	H		1	24	-	471	1900	792	59.5%	-	-	-	1.1	8.2	6.1	10/2
		C1	Stream: 1 PRC for Signalled Lanes (%)		37.9		Total Delay for Signalled Lanes (pcuHr):		10.91		Cycle Time (s):		60					
		C1	Stream: 2 PRC for Signalled Lanes (%)		20.8		Total Delay for Signalled Lanes (pcuHr):		11.20		Cycle Time (s):		60					
		C1	Stream: 3 PRC for Signalled Lanes (%)		55.2		Total Delay for Signalled Lanes (pcuHr):		5.20		Cycle Time (s):		60					
		C1	Stream: 4 PRC for Signalled Lanes (%)		25.7		Total Delay for Signalled Lanes (pcuHr):		6.25		Cycle Time (s):		60					
			PRC Over All Lanes (%)		20.8		Total Delay Over All Lanes(pcuHr):		35.42									

Basic Results Summary

Scenario 2: '2021 Base PM (Survey)' (FG2: '2021 Base PM (Survey)', Plan 1: 'Network Control Plan 1')

Network Layout Diagram

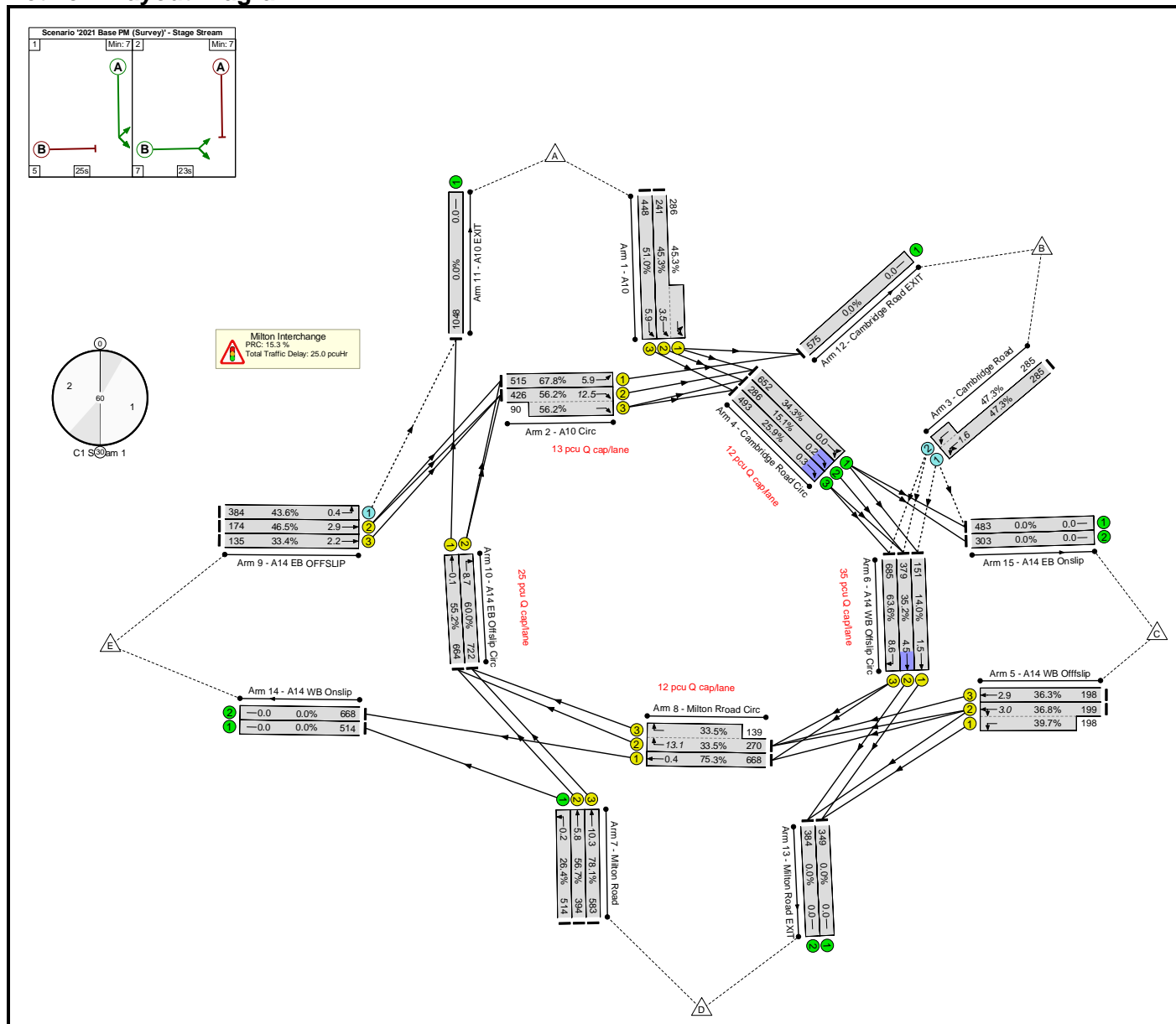

Basic Results Summary

Network Results

Item	Lane Description	Lane Type	Full Phase	Arrow Phase	Num Greens	Total Green (s)	Arrow Green (s)	Demand Flow (pcu)	Sat Flow (pcu/Hr)	Capacity (pcu)	Deg Sat (%)	Turners In Gaps (pcu)	Turners When Unopposed (pcu)	Turners In Intergreen (pcu)	Total Delay (pcuHr)	Av. Delay Per PCU (s/pcu)	Mean Max Queue (pcu)	Item
Network: Milton Interchange	-	-	-		-	-	-	-	-	-	78.1%	1383	141	0	25.0	-	-	Network: Milton Interchange
Milton Interchange	-	-	-		-	-	-	-	-	-	78.1%	1383	141	0	25.0	-	-	Milton Interchange
1/2+1/1	A10 Ahead Left	U	A		1	25	-	527	2057:1910	532+631	45.3 : 45.3%	-	-	-	2.0	14.0	3.5	1/2+1/1
1/3	A10 Ahead	U	A		1	25	-	448	2029	879	51.0%	-	-	-	2.1	16.5	5.9	1/3
2/1	A10 Circ Ahead	U	B		1	23	-	515	1900	760	67.8%	-	-	-	1.3	9.3	5.9	2/1
2/2+2/3	A10 Circ Right	U	B		1	23	-	516	1900:1900	759+160	56.2 : 56.2%	-	-	-	2.1	14.9	12.5	2/2+2/3
3/1+3/2	Cambridge Road Left U-Turn	O	-		-	-	-	570	1828:1986	603+603	47.3 : 47.3%	1140	0	0	0.5	3.3	1.6	3/1+3/2
4/1	Cambridge Road Circ Ahead Left	U	-		-	-	-	652	1900	1900	34.3%	-	-	-	0.0	0.0	0.0	4/1
4/2	Cambridge Road Circ Ahead	U	-		-	-	-	286	1900	1900	15.1%	-	-	-	0.0	0.1	0.2	4/2
4/3	Cambridge Road Circ Ahead	U	-		-	-	-	493	1900	1900	25.9%	-	-	-	0.0	0.2	0.3	4/3
5/2+5/1	A14 WB Offslip Ahead Left	U	C		1	15	-	397	2029:1871	541+499	36.8 : 39.7%	-	-	-	2.3	20.8	3.0	5/2+5/1
5/3	A14 WB Offslip Ahead	U	C		1	15	-	198	2044	545	36.3%	-	-	-	1.3	23.1	2.9	5/3
6/1	A14 WB Offslip Circ Ahead	U	D		1	33	-	151	1900	1077	14.0%	-	-	-	0.3	6.4	1.5	6/1
6/2	A14 WB Offslip Circ Ahead	U	D		1	33	-	379	1900	1077	35.2%	-	-	-	0.4	3.4	4.5	6/2

Basic Results Summary

6/3	A14 WB Offslip Circ Right	U	D		1	33	-	685	1900	1077	63.6%	-	-	-	0.7	3.7	8.6	6/3
7/1	Milton Road Left	U	-		-	-	-	514	1946	1946	26.4%	-	-	-	0.2	1.3	0.2	7/1
7/2	Milton Road Ahead	U	E		1	21	-	394	1894	694	56.7%	-	-	-	2.3	21.2	5.8	7/2
7/3	Milton Road Ahead	U	E		1	21	-	583	2037	747	78.1%	-	-	-	4.5	27.6	10.3	7/3
8/1	Milton Road Circ Ahead	U	F		1	27	-	668	1900	887	75.3%	-	-	-	0.2	1.1	0.4	8/1
8/2+8/3	Milton Road Circ Right	U	F		1	27	-	409	1900:1900	806+415	33.5 : 33.5%	-	-	-	1.8	16.1	13.1	8/2+8/3
9/1	A14 EB OFFSLIP Left	O	-		-	-	-	384	1894	881	43.6%	243	141	0	0.4	3.6	0.4	9/1
9/2	A14 EB OFFSLIP Ahead	U	G		1	11	-	174	1871	374	46.5%	-	-	-	1.5	30.1	2.9	9/2
9/3	A14 EB OFFSLIP Ahead	U	G		1	11	-	135	2018	404	33.4%	-	-	-	1.0	27.3	2.2	9/3
10/1	A14 EB Offslip Circ Ahead	U	H		1	37	-	664	1900	1203	55.2%	-	-	-	0.0	0.1	0.1	10/1
10/2	A14 EB Offslip Circ Right	U	H		1	37	-	722	1900	1203	60.0%	-	-	-	0.1	0.4	8.7	10/2

C1	Stream: 1 PRC for Signalled Lanes (%)	32.8	Total Delay for Signalled Lanes (pcuHr):	7.57	Cycle Time (s):	60
C1	Stream: 2 PRC for Signalled Lanes (%)	41.5	Total Delay for Signalled Lanes (pcuHr):	4.88	Cycle Time (s):	60
C1	Stream: 3 PRC for Signalled Lanes (%)	15.3	Total Delay for Signalled Lanes (pcuHr):	8.82	Cycle Time (s):	60
C1	Stream: 4 PRC for Signalled Lanes (%)	50.0	Total Delay for Signalled Lanes (pcuHr):	2.58	Cycle Time (s):	60
	PRC Over All Lanes (%)	15.3	Total Delay Over All Lanes(pcuHr):	24.99		

Basic Results Summary

Scenario 3: '2026 Base AM (Survey)' (FG3: '2026 Base AM (Survey)', Plan 1: 'Network Control Plan 1')

Network Layout Diagram

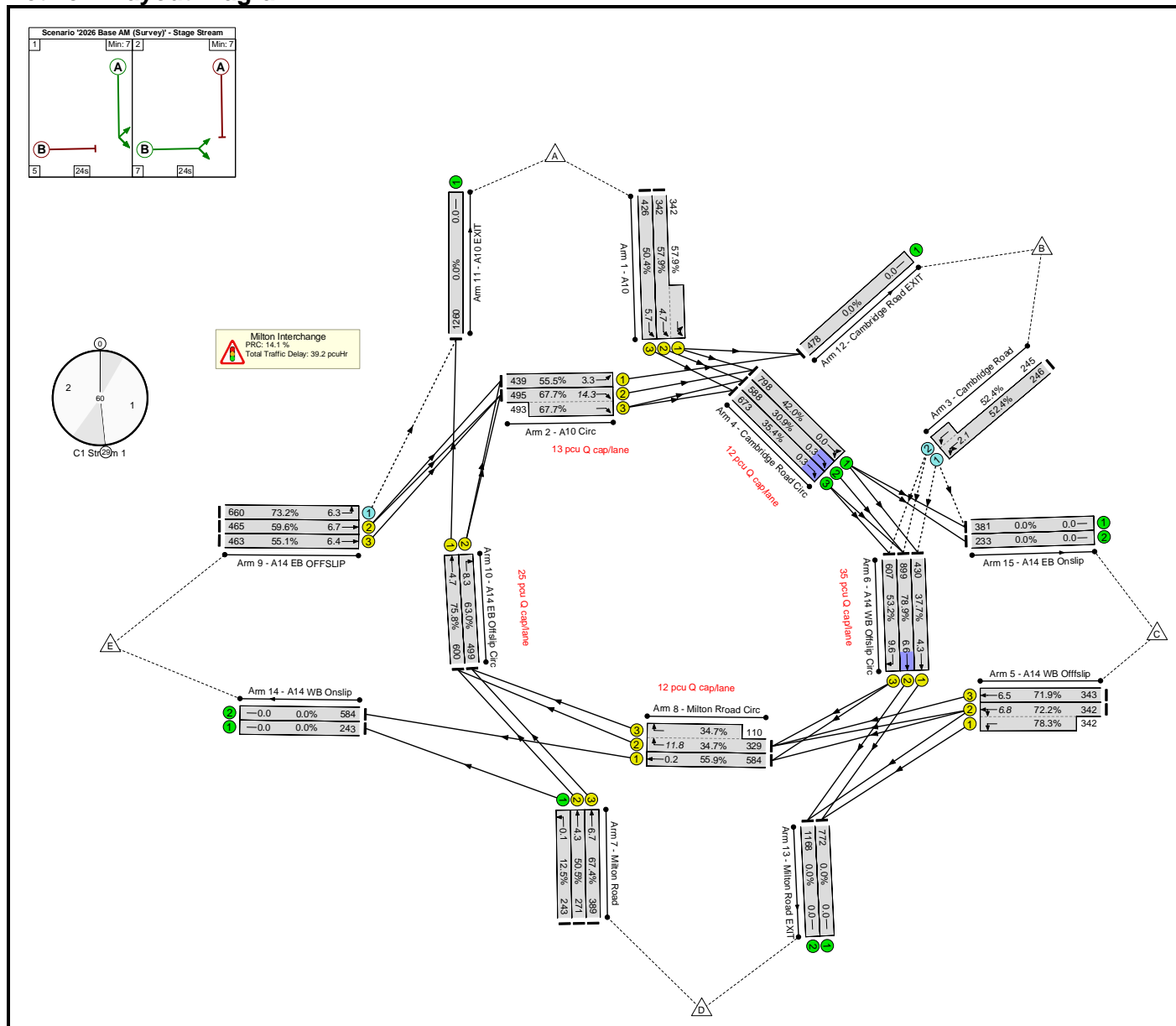

Basic Results Summary

Network Results

Item	Lane Description	Lane Type	Full Phase	Arrow Phase	Num Greens	Total Green (s)	Arrow Green (s)	Demand Flow (pcu)	Sat Flow (pcu/Hr)	Capacity (pcu)	Deg Sat (%)	Turners In Gaps (pcu)	Turners When Unopposed (pcu)	Turners In Intergreen (pcu)	Total Delay (pcuHr)	Av. Delay Per PCU (s/pcu)	Mean Max Queue (pcu)	Item
Network: Milton Interchange	-	-	-		-	-	-	-	-	-	78.9%	1242	400	0	39.2	-	-	Network: Milton Interchange
Milton Interchange	-	-	-		-	-	-	-	-	-	78.9%	1242	400	0	39.2	-	-	Milton Interchange
1/2+1/1	A10 Ahead Left	U	A		1	24	-	684	2057:1910	590+590	57.9 : 57.9%	-	-	-	3.0	16.0	4.7	1/2+1/1
1/3	A10 Ahead	U	A		1	24	-	426	2029	845	50.4%	-	-	-	2.0	17.2	5.7	1/3
2/1	A10 Circ Ahead	U	B		1	24	-	439	1900	792	55.5%	-	-	-	1.1	8.8	3.3	2/1
2/2+2/3	A10 Circ Right	U	B		1	24	-	988	1900:1900	731+728	67.7 : 67.7%	-	-	-	4.3	15.8	14.3	2/2+2/3
3/1+3/2	Cambridge Road Left U-Turn	O	-		-	-	-	491	1828:1986	470+468	52.4 : 52.4%	982	0	0	0.8	6.2	2.1	3/1+3/2
4/1	Cambridge Road Circ Ahead Left	U	-		-	-	-	798	1900	1900	42.0%	-	-	-	0.0	0.0	0.0	4/1
4/2	Cambridge Road Circ Ahead	U	-		-	-	-	588	1900	1900	30.9%	-	-	-	0.0	0.1	0.3	4/2
4/3	Cambridge Road Circ Ahead	U	-		-	-	-	673	1900	1900	35.4%	-	-	-	0.0	0.1	0.3	4/3
5/2+5/1	A14 WB Offslip Ahead Left	U	C		1	13	-	684	2029:1871	473+437	72.2 : 78.3%	-	-	-	5.6	29.3	6.8	5/2+5/1
5/3	A14 WB Offslip Ahead	U	C		1	13	-	343	2044	477	71.9%	-	-	-	3.3	34.4	6.5	5/3
6/1	A14 WB Offslip Circ Ahead	U	D		1	35	-	430	1900	1140	37.7%	-	-	-	0.3	2.5	4.3	6/1
6/2	A14 WB Offslip Circ Ahead	U	D		1	35	-	899	1900	1140	78.9%	-	-	-	1.2	5.0	6.6	6/2

Basic Results Summary

6/3	A14 WB Offslip Circ Right	U	D		1	35	-	607	1900	1140	53.2%	-	-	-	1.8	10.8	9.6	6/3
7/1	Milton Road Left	U	-		-	-	-	243	1946	1946	12.5%	-	-	-	0.1	1.1	0.1	7/1
7/2	Milton Road Ahead	U	E		1	16	-	271	1894	537	50.5%	-	-	-	1.9	24.7	4.3	7/2
7/3	Milton Road Ahead	U	E		1	16	-	389	2037	577	67.4%	-	-	-	3.1	28.5	6.7	7/3
8/1	Milton Road Circ Ahead	U	F		1	32	-	584	1900	1045	55.9%	-	-	-	0.1	0.4	0.2	8/1
8/2+8/3	Milton Road Circ Right	U	F		1	32	-	439	1900:1900	948+317	34.7 : 34.7%	-	-	-	1.6	13.3	11.8	8/2+8/3
9/1	A14 EB OFFSLIP Left	O	-		-	-	-	660	1894	902	73.2%	260	400	0	1.5	8.4	6.3	9/1
9/2	A14 EB OFFSLIP Ahead	U	G		1	24	-	465	1871	780	59.6%	-	-	-	2.5	19.3	6.7	9/2
9/3	A14 EB OFFSLIP Ahead	U	G		1	24	-	463	2018	841	55.1%	-	-	-	2.3	18.0	6.4	9/3
10/1	A14 EB Offslip Circ Ahead	U	H		1	24	-	600	1900	792	75.8%	-	-	-	1.0	6.3	4.7	10/1
10/2	A14 EB Offslip Circ Right	U	H		1	24	-	499	1900	792	63.0%	-	-	-	1.5	10.7	8.3	10/2
		C1	Stream: 1 PRC for Signalled Lanes (%)		33.0		Total Delay for Signalled Lanes (pcuHr):		10.48		Cycle Time (s):		60					
		C1	Stream: 2 PRC for Signalled Lanes (%)		14.1		Total Delay for Signalled Lanes (pcuHr):		12.21		Cycle Time (s):		60					
		C1	Stream: 3 PRC for Signalled Lanes (%)		33.5		Total Delay for Signalled Lanes (pcuHr):		6.64		Cycle Time (s):		60					
		C1	Stream: 4 PRC for Signalled Lanes (%)		18.8		Total Delay for Signalled Lanes (pcuHr):		7.34		Cycle Time (s):		60					
				PRC Over All Lanes (%)		14.1		Total Delay Over All Lanes(pcuHr):		39.16								

Basic Results Summary

Scenario 4: '2026 Base PM (Survey)' (FG4: '2026 Base PM (Survey)', Plan 1: 'Network Control Plan 1')

Network Layout Diagram

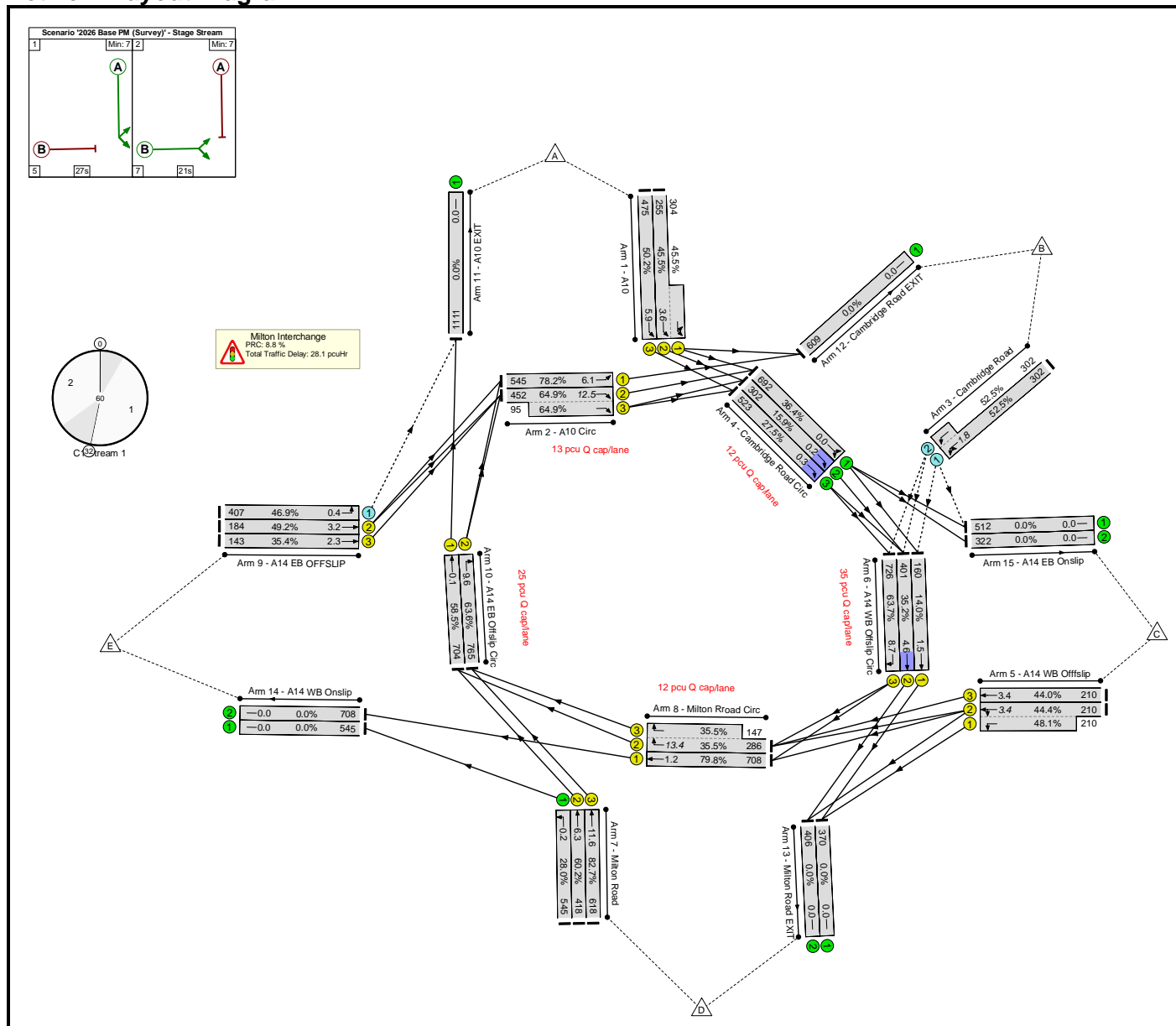

Basic Results Summary

Network Results

Item	Lane Description	Lane Type	Full Phase	Arrow Phase	Num Greens	Total Green (s)	Arrow Green (s)	Demand Flow (pcu)	Sat Flow (pcu/Hr)	Capacity (pcu)	Deg Sat (%)	Turners In Gaps (pcu)	Turners When Unopposed (pcu)	Turners In Intergreen (pcu)	Total Delay (pcuHr)	Av. Delay Per PCU (s/pcu)	Mean Max Queue (pcu)	Item
Network: Milton Interchange	-	-	-		-	-	-	-	-	-	82.7%	1466	149	0	28.1	-	-	Network: Milton Interchange
Milton Interchange	-	-	-		-	-	-	-	-	-	82.7%	1466	149	0	28.1	-	-	Milton Interchange
1/2+1/1	A10 Ahead Left	U	A		1	27	-	559	2057:1910	560+668	45.5 : 45.5%	-	-	-	2.0	12.7	3.6	1/2+1/1
1/3	A10 Ahead	U	A		1	27	-	475	2029	947	50.2%	-	-	-	2.0	15.0	5.9	1/3
2/1	A10 Circ Ahead	U	B		1	21	-	545	1900	697	78.2%	-	-	-	1.7	11.5	6.1	2/1
2/2+2/3	A10 Circ Right	U	B		1	21	-	547	1900:1900	697+146	64.9 : 64.9%	-	-	-	2.7	17.5	12.5	2/2+2/3
3/1+3/2	Cambridge Road Left U-Turn	O	-		-	-	-	604	1828:1986	576+576	52.5 : 52.5%	1208	0	0	0.6	3.8	1.8	3/1+3/2
4/1	Cambridge Road Circ Ahead Left	U	-		-	-	-	692	1900	1900	36.4%	-	-	-	0.0	0.0	0.0	4/1
4/2	Cambridge Road Circ Ahead	U	-		-	-	-	302	1900	1900	15.9%	-	-	-	0.0	0.1	0.2	4/2
4/3	Cambridge Road Circ Ahead	U	-		-	-	-	523	1900	1900	27.5%	-	-	-	0.0	0.2	0.3	4/3
5/2+5/1	A14 WB Offslip Ahead Left	U	C		1	13	-	420	2029:1871	473+437	44.4 : 48.1%	-	-	-	2.7	23.4	3.4	5/2+5/1
5/3	A14 WB Offslip Ahead	U	C		1	13	-	210	2044	477	44.0%	-	-	-	1.5	26.4	3.4	5/3
6/1	A14 WB Offslip Circ Ahead	U	D		1	35	-	160	1900	1140	14.0%	-	-	-	0.3	6.3	1.5	6/1
6/2	A14 WB Offslip Circ Ahead	U	D		1	35	-	401	1900	1140	35.2%	-	-	-	0.4	3.8	4.6	6/2

Basic Results Summary

6/3	A14 WB Offslip Circ Right	U	D		1	35	-	726	1900	1140	63.7%	-	-	-	0.7	3.3	8.7	6/3
7/1	Milton Road Left	U	-		-	-	-	545	1946	1946	28.0%	-	-	-	0.2	1.3	0.2	7/1
7/2	Milton Road Ahead	U	E		1	21	-	418	1894	694	60.2%	-	-	-	2.5	21.9	6.3	7/2
7/3	Milton Road Ahead	U	E		1	21	-	618	2037	747	82.7%	-	-	-	5.3	30.8	11.6	7/3
8/1	Milton Road Circ Ahead	U	F		1	27	-	708	1900	887	79.8%	-	-	-	0.6	3.1	1.2	8/1
8/2+8/3	Milton Road Circ Right	U	F		1	27	-	433	1900:1900	806+414	35.5 : 35.5%	-	-	-	1.5	12.7	13.4	8/2+8/3
9/1	A14 EB OFFSLIP Left	O	-		-	-	-	407	1894	868	46.9%	258	149	0	0.4	3.9	0.4	9/1
9/2	A14 EB OFFSLIP Ahead	U	G		1	11	-	184	1871	374	49.2%	-	-	-	1.6	30.7	3.2	9/2
9/3	A14 EB OFFSLIP Ahead	U	G		1	11	-	143	2018	404	35.4%	-	-	-	1.1	27.6	2.3	9/3
10/1	A14 EB Offslip Circ Ahead	U	H		1	37	-	704	1900	1203	58.5%	-	-	-	0.0	0.2	0.1	10/1
10/2	A14 EB Offslip Circ Right	U	H		1	37	-	765	1900	1203	63.6%	-	-	-	0.1	0.5	9.6	10/2

C1	Stream: 1 PRC for Signalled Lanes (%)	15.0	Total Delay for Signalled Lanes (pcuHr):	8.34	Cycle Time (s):	60
C1	Stream: 2 PRC for Signalled Lanes (%)	41.3	Total Delay for Signalled Lanes (pcuHr):	5.64	Cycle Time (s):	60
C1	Stream: 3 PRC for Signalled Lanes (%)	8.8	Total Delay for Signalled Lanes (pcuHr):	9.96	Cycle Time (s):	60
C1	Stream: 4 PRC for Signalled Lanes (%)	41.6	Total Delay for Signalled Lanes (pcuHr):	2.79	Cycle Time (s):	60
	PRC Over All Lanes (%)	8.8	Total Delay Over All Lanes(pcuHr):	28.05		

Basic Results Summary

Scenario 5: '2028 Base AM (Survey)' (FG5: '2028 Base AM (Survey)', Plan 1: 'Network Control Plan 1')

Network Layout Diagram

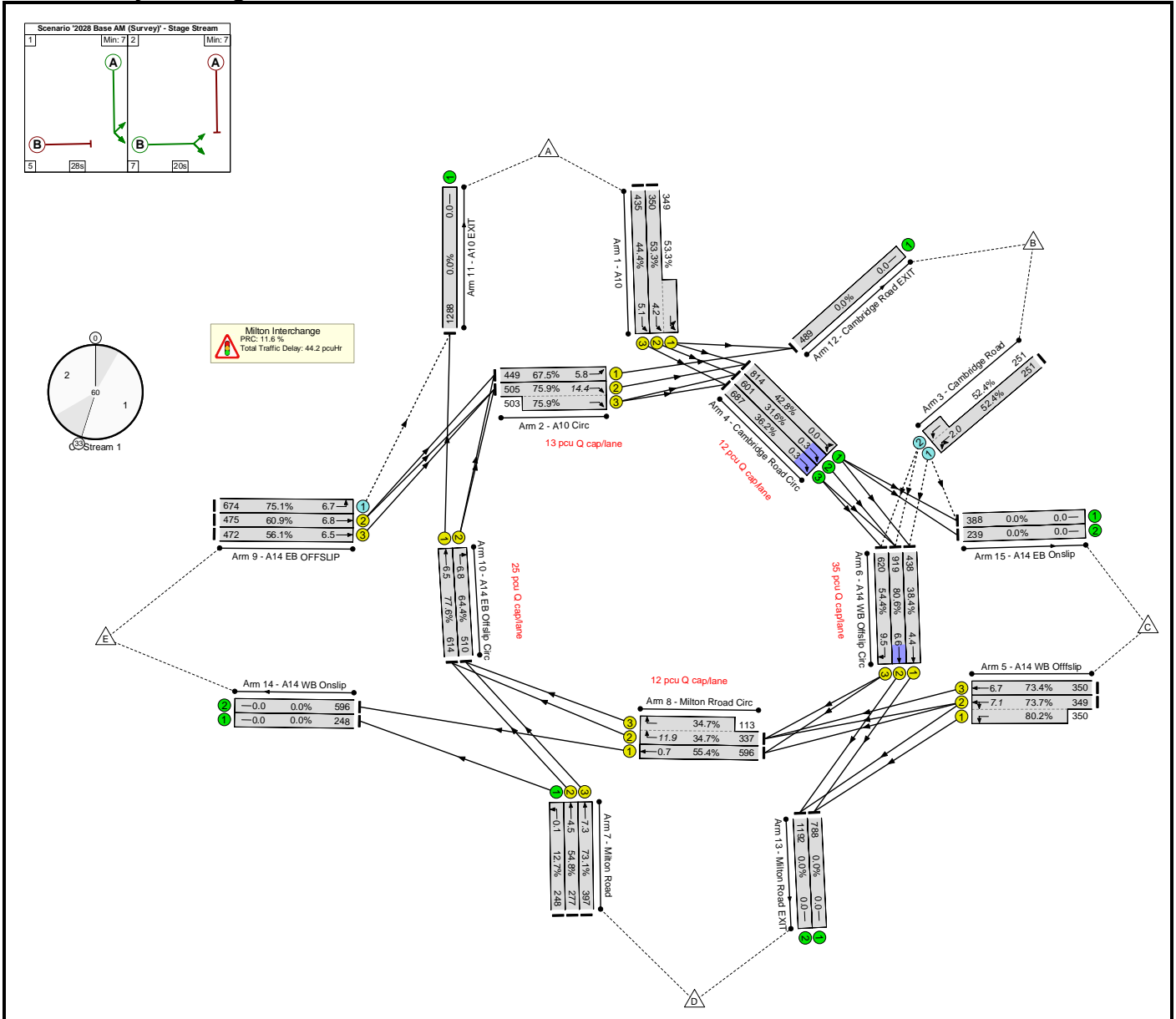

Basic Results Summary

Network Results

Item	Lane Description	Lane Type	Full Phase	Arrow Phase	Num Greens	Total Green (s)	Arrow Green (s)	Demand Flow (pcu)	Sat Flow (pcu/Hr)	Capacity (pcu)	Deg Sat (%)	Turners In Gaps (pcu)	Turners When Unopposed (pcu)	Turners In Intergreen (pcu)	Total Delay (pcuHr)	Av. Delay Per PCU (s/pcu)	Mean Max Queue (pcu)	Item
Network: Milton Interchange	-	-	-		-	-	-	-	-	-	80.6%	1260	418	0	44.2	-	-	Network: Milton Interchange
Milton Interchange	-	-	-		-	-	-	-	-	-	80.6%	1260	418	0	44.2	-	-	Milton Interchange
1/2+1/1	A10 Ahead Left	U	A		1	28	-	699	2057:1910	657+655	53.3 : 53.3%	-	-	-	2.5	12.7	4.2	1/2+1/1
1/3	A10 Ahead	U	A		1	28	-	435	2029	981	44.4%	-	-	-	1.6	13.5	5.1	1/3
2/1	A10 Circ Ahead	U	B		1	20	-	449	1900	665	67.5%	-	-	-	2.0	16.4	5.8	2/1
2/2+2/3	A10 Circ Right	U	B		1	20	-	1008	1900:1900	665+663	75.9 : 75.9%	-	-	-	7.3	26.1	14.4	2/2+2/3
3/1+3/2	Cambridge Road Left U-Turn	O	-		-	-	-	502	1828:1986	479+479	52.4 : 52.4%	1004	0	0	0.8	5.8	2.0	3/1+3/2
4/1	Cambridge Road Circ Ahead Left	U	-		-	-	-	814	1900	1900	42.8%	-	-	-	0.0	0.0	0.0	4/1
4/2	Cambridge Road Circ Ahead	U	-		-	-	-	601	1900	1900	31.6%	-	-	-	0.0	0.1	0.3	4/2
4/3	Cambridge Road Circ Ahead	U	-		-	-	-	687	1900	1900	36.2%	-	-	-	0.0	0.1	0.3	4/3
5/2+5/1	A14 WB Offslip Ahead Left	U	C		1	13	-	699	2029:1871	473+437	73.7 : 80.2%	-	-	-	5.8	29.9	7.1	5/2+5/1
5/3	A14 WB Offslip Ahead	U	C		1	13	-	350	2044	477	73.4%	-	-	-	3.4	35.2	6.7	5/3
6/1	A14 WB Offslip Circ Ahead	U	D		1	35	-	438	1900	1140	38.4%	-	-	-	0.5	4.2	4.4	6/1
6/2	A14 WB Offslip Circ Ahead	U	D		1	35	-	919	1900	1140	80.6%	-	-	-	2.0	7.7	6.6	6/2

Basic Results Summary

6/3	A14 WB Offslip Circ Right	U	D		1	35	-	620	1900	1140	54.4%	-	-	-	3.0	17.4	9.5	6/3
7/1	Milton Road Left	U	-		-	-	-	248	1946	1946	12.7%	-	-	-	0.1	1.1	0.1	7/1
7/2	Milton Road Ahead	U	E		1	15	-	277	1894	505	54.8%	-	-	-	2.1	26.8	4.5	7/2
7/3	Milton Road Ahead	U	E		1	15	-	397	2037	543	73.1%	-	-	-	3.5	32.1	7.3	7/3
8/1	Milton Road Circ Ahead	U	F		1	33	-	596	1900	1077	55.4%	-	-	-	0.2	1.1	0.7	8/1
8/2+8/3	Milton Road Circ Right	U	F		1	33	-	450	1900:1900	972+326	34.7 : 34.7%	-	-	-	0.5	4.2	11.9	8/2+8/3
9/1	A14 EB OFFSLIP Left	O	-		-	-	-	674	1894	897	75.1%	256	418	0	1.6	8.7	6.7	9/1
9/2	A14 EB OFFSLIP Ahead	U	G		1	24	-	475	1871	780	60.9%	-	-	-	2.6	19.6	6.8	9/2
9/3	A14 EB OFFSLIP Ahead	U	G		1	24	-	472	2018	841	56.1%	-	-	-	2.4	18.2	6.5	9/3
10/1	A14 EB Offslip Circ Ahead	U	H		1	24	-	614	1900	792	77.6%	-	-	-	1.6	9.3	6.5	10/1
10/2	A14 EB Offslip Circ Right	U	H		1	24	-	510	1900	792	64.4%	-	-	-	0.6	4.4	6.8	10/2
		C1	Stream: 1 PRC for Signalled Lanes (%)		18.5		Total Delay for Signalled Lanes (pcuHr):		13.45		Cycle Time (s):		60					
		C1	Stream: 2 PRC for Signalled Lanes (%)		11.6		Total Delay for Signalled Lanes (pcuHr):		14.68		Cycle Time (s):		60					
		C1	Stream: 3 PRC for Signalled Lanes (%)		23.1		Total Delay for Signalled Lanes (pcuHr):		6.32		Cycle Time (s):		60					
		C1	Stream: 4 PRC for Signalled Lanes (%)		16.0		Total Delay for Signalled Lanes (pcuHr):		7.18		Cycle Time (s):		60					
			PRC Over All Lanes (%)		11.6		Total Delay Over All Lanes(pcuHr):		44.19									

Basic Results Summary

Scenario 6: '2028 Base PM (Survey)' (FG6: '2028 Base PM (Survey)', Plan 1: 'Network Control Plan 1')

Network Layout Diagram

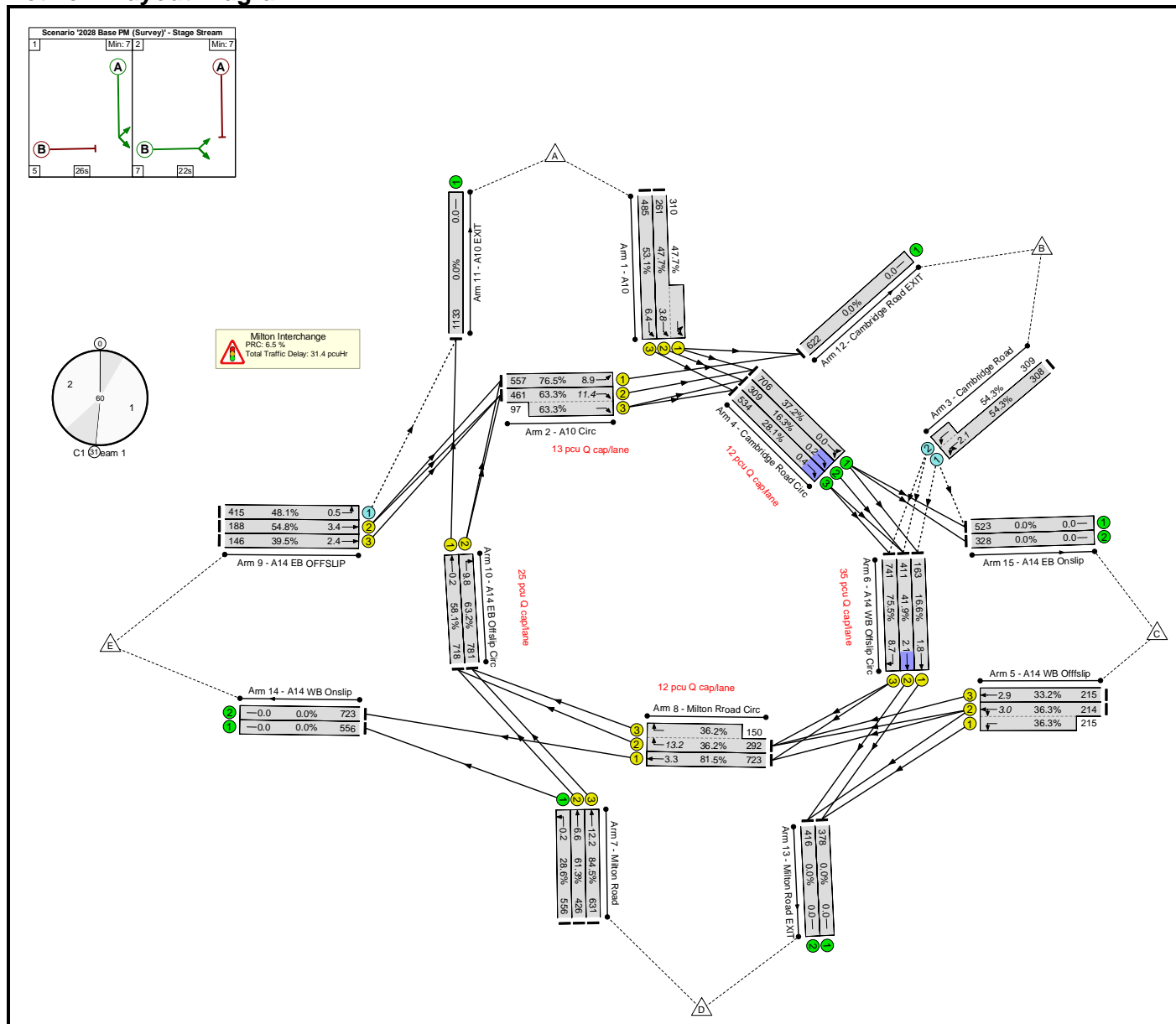

Basic Results Summary

Network Results

Item	Lane Description	Lane Type	Full Phase	Arrow Phase	Num Greens	Total Green (s)	Arrow Green (s)	Demand Flow (pcu)	Sat Flow (pcu/Hr)	Capacity (pcu)	Deg Sat (%)	Turners In Gaps (pcu)	Turners When Unopposed (pcu)	Turners In Intergreen (pcu)	Total Delay (pcuHr)	Av. Delay Per PCU (s/pcu)	Mean Max Queue (pcu)	Item
Network: Milton Interchange	-	-	-		-	-	-	-	-	-	84.5%	1504	145	0	31.4	-	-	Network: Milton Interchange
Milton Interchange	-	-	-		-	-	-	-	-	-	84.5%	1504	145	0	31.4	-	-	Milton Interchange
1/2+1/1	A10 Ahead Left	U	A		1	26	-	571	2057:1910	547+649	47.7 : 47.7%	-	-	-	2.1	13.5	3.8	1/2+1/1
1/3	A10 Ahead	U	A		1	26	-	485	2029	913	53.1%	-	-	-	2.2	16.1	6.4	1/3
2/1	A10 Circ Ahead	U	B		1	22	-	557	1900	728	76.5%	-	-	-	2.8	18.2	8.9	2/1
2/2+2/3	A10 Circ Right	U	B		1	22	-	558	1900:1900	728+153	63.3 : 63.3%	-	-	-	3.8	24.5	11.4	2/2+2/3
3/1+3/2	Cambridge Road Left U-Turn	O	-		-	-	-	617	1828:1986	567+569	54.3 : 54.3%	1234	0	0	0.7	4.4	2.1	3/1+3/2
4/1	Cambridge Road Circ Ahead Left	U	-		-	-	-	706	1900	1900	37.2%	-	-	-	0.0	0.0	0.0	4/1
4/2	Cambridge Road Circ Ahead	U	-		-	-	-	309	1900	1900	16.3%	-	-	-	0.0	0.1	0.2	4/2
4/3	Cambridge Road Circ Ahead	U	-		-	-	-	534	1900	1900	28.1%	-	-	-	0.0	0.2	0.4	4/3
5/2+5/1	A14 WB Offslip Ahead Left	U	C		1	18	-	429	2029:1871	590+592	36.3 : 36.3%	-	-	-	2.2	18.1	3.0	5/2+5/1
5/3	A14 WB Offslip Ahead	U	C		1	18	-	215	2044	647	33.2%	-	-	-	1.2	19.8	2.9	5/3
6/1	A14 WB Offslip Circ Ahead	U	D		1	30	-	163	1900	982	16.6%	-	-	-	0.4	8.8	1.8	6/1
6/2	A14 WB Offslip Circ Ahead	U	D		1	30	-	411	1900	982	41.9%	-	-	-	0.6	4.8	2.1	6/2

Basic Results Summary

6/3	A14 WB Offslip Circ Right	U	D		1	30	-	741	1900	982	75.5%	-	-	-	0.6	3.1	8.7	6/3
7/1	Milton Road Left	U	-		-	-	-	556	1946	1946	28.6%	-	-	-	0.2	1.3	0.2	7/1
7/2	Milton Road Ahead	U	E		1	21	-	426	1894	694	61.3%	-	-	-	2.6	22.2	6.6	7/2
7/3	Milton Road Ahead	U	E		1	21	-	631	2037	747	84.5%	-	-	-	5.7	32.3	12.2	7/3
8/1	Milton Road Circ Ahead	U	F		1	27	-	723	1900	887	81.5%	-	-	-	1.6	7.9	3.3	8/1
8/2+8/3	Milton Road Circ Right	U	F		1	27	-	442	1900:1900	806+414	36.2 : 36.2%	-	-	-	1.1	9.2	13.2	8/2+8/3
9/1	A14 EB OFFSLIP Left	O	-		-	-	-	415	1894	863	48.1%	270	145	0	0.5	4.0	0.5	9/1
9/2	A14 EB OFFSLIP Ahead	U	G		1	10	-	188	1871	343	54.8%	-	-	-	1.8	33.8	3.4	9/2
9/3	A14 EB OFFSLIP Ahead	U	G		1	10	-	146	2018	370	39.5%	-	-	-	1.2	29.6	2.4	9/3
10/1	A14 EB Offslip Circ Ahead	U	H		1	38	-	718	1900	1235	58.1%	-	-	-	0.0	0.2	0.2	10/1
10/2	A14 EB Offslip Circ Right	U	H		1	38	-	781	1900	1235	63.2%	-	-	-	0.1	0.5	9.8	10/2

C1	Stream: 1 PRC for Signalled Lanes (%)	17.7	Total Delay for Signalled Lanes (pcuHr):	10.92	Cycle Time (s):	60
C1	Stream: 2 PRC for Signalled Lanes (%)	19.2	Total Delay for Signalled Lanes (pcuHr):	4.93	Cycle Time (s):	60
C1	Stream: 3 PRC for Signalled Lanes (%)	6.5	Total Delay for Signalled Lanes (pcuHr):	11.00	Cycle Time (s):	60
C1	Stream: 4 PRC for Signalled Lanes (%)	42.3	Total Delay for Signalled Lanes (pcuHr):	3.11	Cycle Time (s):	60
	PRC Over All Lanes (%)	6.5	Total Delay Over All Lanes(pcuHr):	31.42		

Basic Results Summary

Scenario 7: '2033 Base AM' (FG7: '2033 Base AM', Plan 1: 'Network Control Plan 1')

Network Layout Diagram

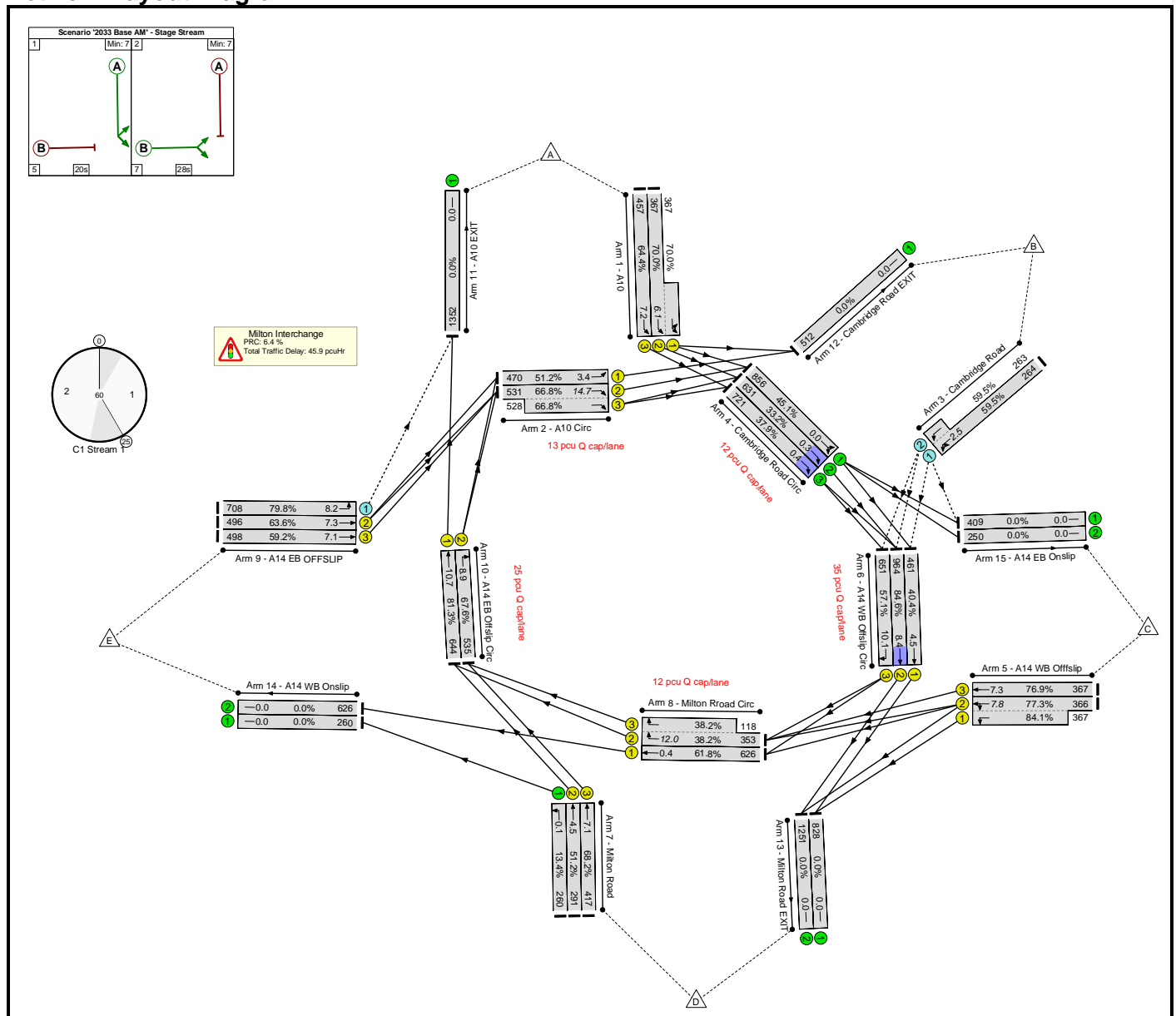

Basic Results Summary

Network Results

Item	Lane Description	Lane Type	Full Phase	Arrow Phase	Num Greens	Total Green (s)	Arrow Green (s)	Demand Flow (pcu)	Sat Flow (pcu/Hr)	Capacity (pcu)	Deg Sat (%)	Turners In Gaps (pcu)	Turners When Unopposed (pcu)	Turners In Intergreen (pcu)	Total Delay (pcuHr)	Av. Delay Per PCU (s/pcu)	Mean Max Queue (pcu)	Item
Network: Milton Interchange	-	-	-		-	-	-	-	-	-	84.6%	1300	462	0	45.9	-	-	Network: Milton Interchange
Milton Interchange	-	-	-		-	-	-	-	-	-	84.6%	1300	462	0	45.9	-	-	Milton Interchange
1/2+1/1	A10 Ahead Left	U	A		1	20	-	734	2057:1910	524+524	70.0 : 70.0%	-	-	-	4.3	21.3	6.1	1/2+1/1
1/3	A10 Ahead	U	A		1	20	-	457	2029	710	64.4%	-	-	-	3.0	23.4	7.2	1/3
2/1	A10 Circ Ahead	U	B		1	28	-	470	1900	918	51.2%	-	-	-	0.9	6.6	3.4	2/1
2/2+2/3	A10 Circ Right	U	B		1	28	-	1059	1900:1900	795+791	66.8 : 66.8%	-	-	-	3.6	12.2	14.7	2/2+2/3
3/1+3/2	Cambridge Road Left U-Turn	O	-		-	-	-	527	1828:1986	444+442	59.5 : 59.5%	1054	0	0	1.0	7.0	2.5	3/1+3/2
4/1	Cambridge Road Circ Ahead Left	U	-		-	-	-	856	1900	1900	45.1%	-	-	-	0.0	0.0	0.0	4/1
4/2	Cambridge Road Circ Ahead	U	-		-	-	-	631	1900	1900	33.2%	-	-	-	0.0	0.2	0.3	4/2
4/3	Cambridge Road Circ Ahead	U	-		-	-	-	721	1900	1900	37.9%	-	-	-	0.0	0.2	0.4	4/3
5/2+5/1	A14 WB Offslip Ahead Left	U	C		1	13	-	733	2029:1871	473+437	77.3 : 84.1%	-	-	-	6.4	31.7	7.8	5/2+5/1
5/3	A14 WB Offslip Ahead	U	C		1	13	-	367	2044	477	76.9%	-	-	-	3.8	37.4	7.3	5/3
6/1	A14 WB Offslip Circ Ahead	U	D		1	35	-	461	1900	1140	40.4%	-	-	-	0.2	1.8	4.5	6/1
6/2	A14 WB Offslip Circ Ahead	U	D		1	35	-	964	1900	1140	84.6%	-	-	-	1.6	6.1	8.4	6/2

Basic Results Summary

6/3	A14 WB Offslip Circ Right	U	D		1	35	-	651	1900	1140	57.1%	-	-	-	1.3	7.1	10.1	6/3	
7/1	Milton Road Left	U	-		-	-	-	260	1946	1946	13.4%	-	-	-	0.1	1.1	0.1	7/1	
7/2	Milton Road Ahead	U	E		1	17	-	291	1894	568	51.2%	-	-	-	1.9	23.8	4.5	7/2	
7/3	Milton Road Ahead	U	E		1	17	-	417	2037	611	68.2%	-	-	-	3.2	27.7	7.1	7/3	
8/1	Milton Road Circ Ahead	U	F		1	31	-	626	1900	1013	61.8%	-	-	-	0.2	1.0	0.4	8/1	
8/2+8/3	Milton Road Circ Right	U	F		1	31	-	471	1900:1900	925+309	38.2 : 38.2%	-	-	-	1.8	13.4	12.0	8/2+8/3	
9/1	A14 EB OFFSLIP Left	O	-		-	-	-	708	1894	887	79.8%	246	462	0	2.3	11.7	8.2	9/1	
9/2	A14 EB OFFSLIP Ahead	U	G		1	24	-	496	1871	780	63.6%	-	-	-	2.8	20.2	7.3	9/2	
9/3	A14 EB OFFSLIP Ahead	U	G		1	24	-	498	2018	841	59.2%	-	-	-	2.6	18.8	7.1	9/3	
10/1	A14 EB Offslip Circ Ahead	U	H		1	24	-	644	1900	792	81.3%	-	-	-	2.2	12.3	10.7	10/1	
10/2	A14 EB Offslip Circ Right	U	H		1	24	-	535	1900	792	67.6%	-	-	-	2.6	17.7	8.9	10/2	
		C1		Stream: 1 PRC for Signalled Lanes (%)		28.5		Total Delay for Signalled Lanes (pcuHr):		11.75		Cycle Time (s):		60					
		C1		Stream: 2 PRC for Signalled Lanes (%)		6.4		Total Delay for Signalled Lanes (pcuHr):		13.41		Cycle Time (s):		60					
		C1		Stream: 3 PRC for Signalled Lanes (%)		31.9		Total Delay for Signalled Lanes (pcuHr):		7.06		Cycle Time (s):		60					
		C1		Stream: 4 PRC for Signalled Lanes (%)		10.6		Total Delay for Signalled Lanes (pcuHr):		10.20		Cycle Time (s):		60					
				PRC Over All Lanes (%)		6.4		Total Delay Over All Lanes(pcuHr):		45.89									

Basic Results Summary

Scenario 8: '2033 Base PM' (FG8: '2033 Base PM', Plan 1: 'Network Control Plan 1')

Network Layout Diagram

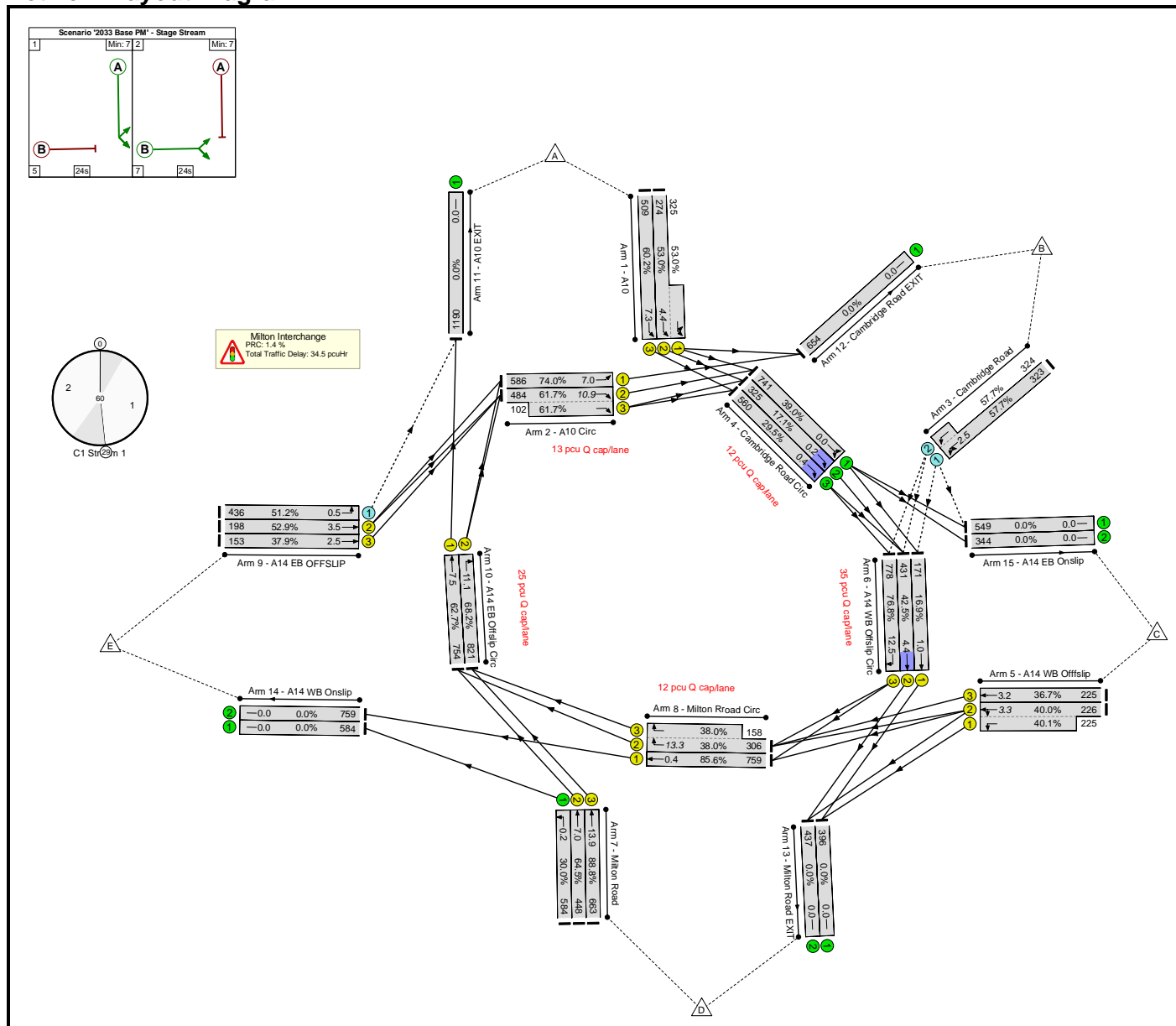

Basic Results Summary

Network Results

Item	Lane Description	Lane Type	Full Phase	Arrow Phase	Num Greens	Total Green (s)	Arrow Green (s)	Demand Flow (pcu)	Sat Flow (pcu/Hr)	Capacity (pcu)	Deg Sat (%)	Turners In Gaps (pcu)	Turners When Unopposed (pcu)	Turners In Intergreen (pcu)	Total Delay (pcuHr)	Av. Delay Per PCU (s/pcu)	Mean Max Queue (pcu)	Item
Network: Milton Interchange	-	-	-		-	-	-	-	-	-	88.8%	1570	160	0	34.5	-	-	Network: Milton Interchange
Milton Interchange	-	-	-		-	-	-	-	-	-	88.8%	1570	160	0	34.5	-	-	Milton Interchange
1/2+1/1	A10 Ahead Left	U	A		1	24	-	599	2057:1910	517+614	53.0 : 53.0%	-	-	-	2.6	15.4	4.4	1/2+1/1
1/3	A10 Ahead	U	A		1	24	-	509	2029	845	60.2%	-	-	-	2.7	19.0	7.3	1/3
2/1	A10 Circ Ahead	U	B		1	24	-	586	1900	792	74.0%	-	-	-	1.8	10.8	7.0	2/1
2/2+2/3	A10 Circ Right	U	B		1	24	-	586	1900:1900	785+165	61.7 : 61.7%	-	-	-	1.1	7.0	10.9	2/2+2/3
3/1+3/2	Cambridge Road Left U-Turn	O	-		-	-	-	647	1828:1986	560+562	57.7 : 57.7%	1294	0	0	0.9	4.9	2.5	3/1+3/2
4/1	Cambridge Road Circ Ahead Left	U	-		-	-	-	741	1900	1900	39.0%	-	-	-	0.0	0.0	0.0	4/1
4/2	Cambridge Road Circ Ahead	U	-		-	-	-	325	1900	1900	17.1%	-	-	-	0.0	0.1	0.2	4/2
4/3	Cambridge Road Circ Ahead	U	-		-	-	-	560	1900	1900	29.5%	-	-	-	0.0	0.3	0.4	4/3
5/2+5/1	A14 WB Offslip Ahead Left	U	C		1	17	-	451	2029:1871	566+561	40.0 : 40.1%	-	-	-	2.4	19.3	3.3	5/2+5/1
5/3	A14 WB Offslip Ahead	U	C		1	17	-	225	2044	613	36.7%	-	-	-	1.3	21.2	3.2	5/3
6/1	A14 WB Offslip Circ Ahead	U	D		1	31	-	171	1900	1013	16.9%	-	-	-	0.2	4.9	1.0	6/1
6/2	A14 WB Offslip Circ Ahead	U	D		1	31	-	431	1900	1013	42.5%	-	-	-	0.7	5.8	4.4	6/2

Basic Results Summary

6/3	A14 WB Offslip Circ Right	U	D		1	31	-	778	1900	1013	76.8%	-	-	-	2.5	11.8	12.5	6/3
7/1	Milton Road Left	U	-		-	-	-	584	1946	1946	30.0%	-	-	-	0.2	1.3	0.2	7/1
7/2	Milton Road Ahead	U	E		1	21	-	448	1894	694	64.5%	-	-	-	2.9	23.0	7.0	7/2
7/3	Milton Road Ahead	U	E		1	21	-	663	2037	747	88.8%	-	-	-	6.9	37.6	13.9	7/3
8/1	Milton Road Circ Ahead	U	F		1	27	-	759	1900	887	85.6%	-	-	-	0.2	0.9	0.4	8/1
8/2+8/3	Milton Road Circ Right	U	F		1	27	-	464	1900:1900	806+416	38.0 : 38.0%	-	-	-	2.3	17.9	13.3	8/2+8/3
9/1	A14 EB OFFSLIP Left	O	-		-	-	-	436	1894	851	51.2%	276	160	0	0.5	4.3	0.5	9/1
9/2	A14 EB OFFSLIP Ahead	U	G		1	11	-	198	1871	374	52.9%	-	-	-	1.7	31.6	3.5	9/2
9/3	A14 EB OFFSLIP Ahead	U	G		1	11	-	153	2018	404	37.9%	-	-	-	1.2	27.9	2.5	9/3
10/1	A14 EB Offslip Circ Ahead	U	H		1	37	-	754	1900	1203	62.7%	-	-	-	0.9	4.1	7.5	10/1
10/2	A14 EB Offslip Circ Right	U	H		1	37	-	821	1900	1203	68.2%	-	-	-	1.4	6.2	11.1	10/2
		C1	Stream: 1 PRC for Signalled Lanes (%)		21.6		Total Delay for Signalled Lanes (pcuHr):		8.15		Cycle Time (s):		60					
		C1	Stream: 2 PRC for Signalled Lanes (%)		17.2		Total Delay for Signalled Lanes (pcuHr):		7.21		Cycle Time (s):		60					
		C1	Stream: 3 PRC for Signalled Lanes (%)		1.4		Total Delay for Signalled Lanes (pcuHr):		12.27		Cycle Time (s):		60					
		C1	Stream: 4 PRC for Signalled Lanes (%)		31.9		Total Delay for Signalled Lanes (pcuHr):		5.18		Cycle Time (s):		60					
			PRC Over All Lanes (%)		1.4		Total Delay Over All Lanes(pcuHr):		34.50									

Basic Results Summary

Scenario 9: '2038 Base AM (Survey)' (FG9: '2038 Base AM (Survey)', Plan 1: 'Network Control Plan 1')

Network Layout Diagram

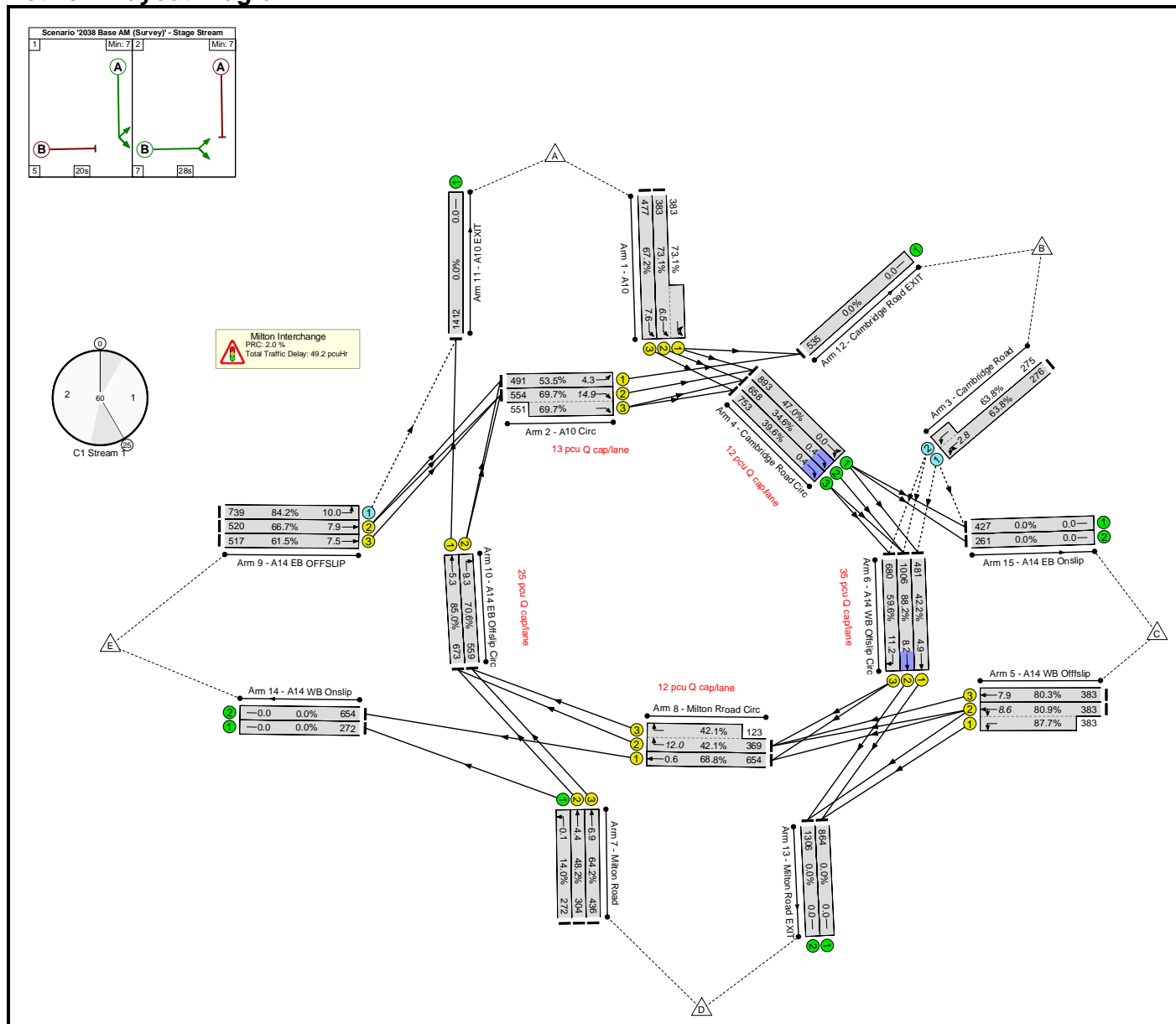

Basic Results Summary

Network Results

Item	Lane Description	Lane Type	Full Phase	Arrow Phase	Num Greens	Total Green (s)	Arrow Green (s)	Demand Flow (pcu)	Sat Flow (pcu/Hr)	Capacity (pcu)	Deg Sat (%)	Turners In Gaps (pcu)	Turners When Unopposed (pcu)	Turners In Intergreen (pcu)	Total Delay (pcuHr)	Av. Delay Per PCU (s/pcu)	Mean Max Queue (pcu)	Item
Network: Milton Interchange	-	-	-		-	-	-	-	-	-	88.2%	1338	503	0	49.2	-	-	Network: Milton Interchange
Milton Interchange	-	-	-		-	-	-	-	-	-	88.2%	1338	503	0	49.2	-	-	Milton Interchange
1/2+1/1	A10 Ahead Left	U	A		1	20	-	766	2057:1910	524+524	73.1 : 73.1%	-	-	-	4.7	22.0	6.5	1/2+1/1
1/3	A10 Ahead	U	A		1	20	-	477	2029	710	67.2%	-	-	-	3.2	24.2	7.6	1/3
2/1	A10 Circ Ahead	U	B		1	28	-	491	1900	918	53.5%	-	-	-	1.3	9.2	4.3	2/1
2/2+2/3	A10 Circ Right	U	B		1	28	-	1105	1900:1900	795+791	69.7 : 69.7%	-	-	-	5.2	16.8	14.9	2/2+2/3
3/1+3/2	Cambridge Road Left U-Turn	O	-		-	-	-	551	1828:1986	432+431	63.8 : 63.8%	1102	0	0	1.3	8.8	2.8	3/1+3/2
4/1	Cambridge Road Circ Ahead Left	U	-		-	-	-	893	1900	1900	47.0%	-	-	-	0.0	0.0	0.0	4/1
4/2	Cambridge Road Circ Ahead	U	-		-	-	-	658	1900	1900	34.6%	-	-	-	0.0	0.2	0.4	4/2
4/3	Cambridge Road Circ Ahead	U	-		-	-	-	753	1900	1900	39.6%	-	-	-	0.0	0.2	0.4	4/3
5/2+5/1	A14 WB Offslip Ahead Left	U	C		1	13	-	766	2029:1871	473+437	80.9 : 87.7%	-	-	-	7.2	34.0	8.6	5/2+5/1
5/3	A14 WB Offslip Ahead	U	C		1	13	-	383	2044	477	80.3%	-	-	-	4.3	40.1	7.9	5/3
6/1	A14 WB Offslip Circ Ahead	U	D		1	35	-	481	1900	1140	42.2%	-	-	-	0.3	2.1	4.9	6/1
6/2	A14 WB Offslip Circ Ahead	U	D		1	35	-	1006	1900	1140	88.2%	-	-	-	1.5	5.3	8.2	6/2

Basic Results Summary

6/3	A14 WB Offslip Circ Right	U	D		1	35	-	680	1900	1140	59.6%	-	-	-	1.9	10.2	11.2	6/3
7/1	Milton Road Left	U	-		-	-	-	272	1946	1946	14.0%	-	-	-	0.1	1.1	0.1	7/1
7/2	Milton Road Ahead	U	E		1	19	-	304	1894	631	48.2%	-	-	-	1.8	21.4	4.4	7/2
7/3	Milton Road Ahead	U	E		1	19	-	436	2037	679	64.2%	-	-	-	2.9	24.3	6.9	7/3
8/1	Milton Road Circ Ahead	U	F		1	29	-	654	1900	950	68.8%	-	-	-	0.0	0.2	0.6	8/1
8/2+8/3	Milton Road Circ Right	U	F		1	29	-	492	1900:1900	877+292	42.1 : 42.1%	-	-	-	1.9	14.2	12.0	8/2+8/3
9/1	A14 EB OFFSLIP Left	O	-		-	-	-	739	1894	878	84.2%	236	503	0	3.0	14.4	10.0	9/1
9/2	A14 EB OFFSLIP Ahead	U	G		1	24	-	520	1871	780	66.7%	-	-	-	3.0	21.0	7.9	9/2
9/3	A14 EB OFFSLIP Ahead	U	G		1	24	-	517	2018	841	61.5%	-	-	-	2.8	19.3	7.5	9/3
10/1	A14 EB Offslip Circ Ahead	U	H		1	24	-	673	1900	792	85.0%	-	-	-	1.1	6.0	5.3	10/1
10/2	A14 EB Offslip Circ Right	U	H		1	24	-	559	1900	792	70.6%	-	-	-	1.6	10.2	9.3	10/2

C1	Stream: 1 PRC for Signalled Lanes (%)	23.2	Total Delay for Signalled Lanes (pcuHr):	14.31	Cycle Time (s):	60
C1	Stream: 2 PRC for Signalled Lanes (%)	2.0	Total Delay for Signalled Lanes (pcuHr):	15.20	Cycle Time (s):	60
C1	Stream: 3 PRC for Signalled Lanes (%)	30.7	Total Delay for Signalled Lanes (pcuHr):	6.73	Cycle Time (s):	60
C1	Stream: 4 PRC for Signalled Lanes (%)	5.9	Total Delay for Signalled Lanes (pcuHr):	8.51	Cycle Time (s):	60
	PRC Over All Lanes (%)	2.0	Total Delay Over All Lanes(pcuHr):	49.21		

Basic Results Summary

Scenario 10: '2038 Base PM (Survey)' (FG10: '2038 Base PM (Survey)', Plan 1: 'Network Control Plan 1')

Network Layout Diagram

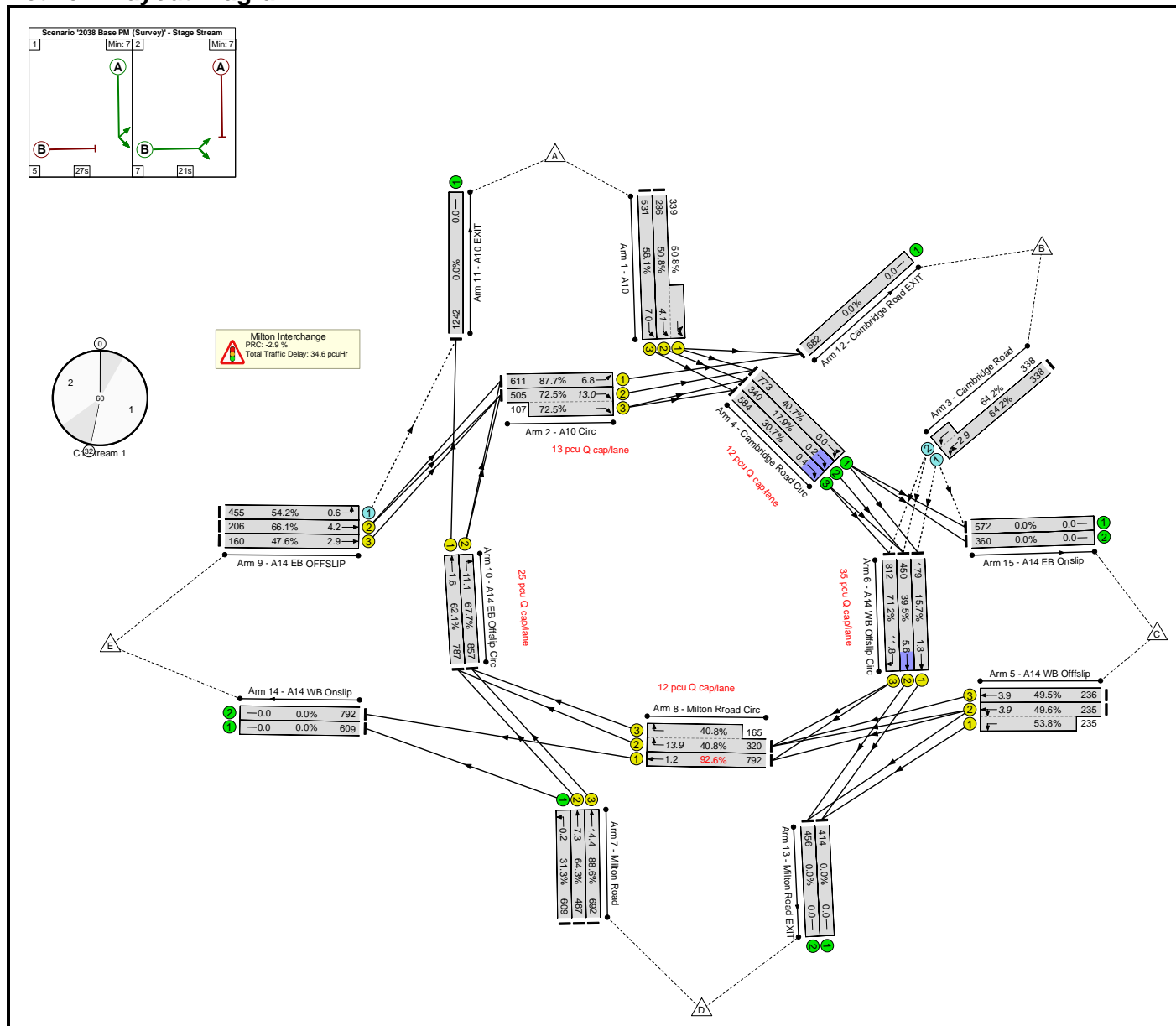

Basic Results Summary

Network Results

Item	Lane Description	Lane Type	Full Phase	Arrow Phase	Num Greens	Total Green (s)	Arrow Green (s)	Demand Flow (pcu)	Sat Flow (pcu/Hr)	Capacity (pcu)	Deg Sat (%)	Turners In Gaps (pcu)	Turners When Unopposed (pcu)	Turners In Intergreen (pcu)	Total Delay (pcuHr)	Av. Delay Per PCU (s/pcu)	Mean Max Queue (pcu)	Item
Network: Milton Interchange	-	-	-		-	-	-	-	-	-	92.6%	1655	152	0	34.6	-	-	Network: Milton Interchange
Milton Interchange	-	-	-		-	-	-	-	-	-	92.6%	1655	152	0	34.6	-	-	Milton Interchange
1/2+1/1	A10 Ahead Left	U	A		1	27	-	625	2057:1910	563+667	50.8 : 50.8%	-	-	-	2.3	13.1	4.1	1/2+1/1
1/3	A10 Ahead	U	A		1	27	-	531	2029	947	56.1%	-	-	-	2.3	15.9	7.0	1/3
2/1	A10 Circ Ahead	U	B		1	21	-	611	1900	697	87.7%	-	-	-	1.6	9.6	6.8	2/1
2/2+2/3	A10 Circ Right	U	B		1	21	-	612	1900:1900	697+148	72.5 : 72.5%	-	-	-	2.7	15.7	13.0	2/2+2/3
3/1+3/2	Cambridge Road Left U-Turn	O	-		-	-	-	676	1828:1986	526+526	64.2 : 64.2%	1352	0	0	1.1	5.7	2.9	3/1+3/2
4/1	Cambridge Road Circ Ahead Left	U	-		-	-	-	773	1900	1900	40.7%	-	-	-	0.0	0.0	0.0	4/1
4/2	Cambridge Road Circ Ahead	U	-		-	-	-	340	1900	1900	17.9%	-	-	-	0.0	0.1	0.2	4/2
4/3	Cambridge Road Circ Ahead	U	-		-	-	-	584	1900	1900	30.7%	-	-	-	0.0	0.3	0.4	4/3
5/2+5/1	A14 WB Offslip Ahead Left	U	C		1	13	-	470	2029:1871	473+437	49.6 : 53.8%	-	-	-	3.2	24.1	3.9	5/2+5/1
5/3	A14 WB Offslip Ahead	U	C		1	13	-	236	2044	477	49.5%	-	-	-	1.8	27.4	3.9	5/3
6/1	A14 WB Offslip Circ Ahead	U	D		1	35	-	179	1900	1140	15.7%	-	-	-	0.3	7.0	1.8	6/1
6/2	A14 WB Offslip Circ Ahead	U	D		1	35	-	450	1900	1140	39.5%	-	-	-	0.7	5.8	5.6	6/2

Basic Results Summary

6/3	A14 WB Offslip Circ Right	U	D		1	35	-	812	1900	1140	71.2%	-	-	-	1.2	5.4	11.8	6/3
7/1	Milton Road Left	U	-		-	-	-	609	1946	1946	31.3%	-	-	-	0.2	1.3	0.2	7/1
7/2	Milton Road Ahead	U	E		1	22	-	467	1894	726	64.3%	-	-	-	2.9	22.0	7.3	7/2
7/3	Milton Road Ahead	U	E		1	22	-	692	2037	781	88.6%	-	-	-	6.9	36.0	14.4	7/3
8/1	Milton Road Circ Ahead	U	F		1	26	-	792	1900	855	92.6%	-	-	-	0.6	2.6	1.2	8/1
8/2+8/3	Milton Road Circ Right	U	F		1	26	-	485	1900:1900	785+405	40.8 : 40.8%	-	-	-	1.8	13.1	13.9	8/2+8/3
9/1	A14 EB OFFSLIP Left	O	-		-	-	-	455	1894	840	54.2%	303	152	0	0.6	4.7	0.6	9/1
9/2	A14 EB OFFSLIP Ahead	U	G		1	9	-	206	1871	312	66.1%	-	-	-	2.3	40.1	4.2	9/2
9/3	A14 EB OFFSLIP Ahead	U	G		1	9	-	160	2018	336	47.6%	-	-	-	1.5	32.8	2.9	9/3
10/1	A14 EB Offslip Circ Ahead	U	H		1	39	-	787	1900	1267	62.1%	-	-	-	0.5	2.4	1.6	10/1
10/2	A14 EB Offslip Circ Right	U	H		1	39	-	857	1900	1267	67.7%	-	-	-	0.1	0.5	11.1	10/2

C1	Stream: 1 PRC for Signalled Lanes (%)	2.6	Total Delay for Signalled Lanes (pcuHr):	8.91	Cycle Time (s):	60
C1	Stream: 2 PRC for Signalled Lanes (%)	26.4	Total Delay for Signalled Lanes (pcuHr):	7.24	Cycle Time (s):	60
C1	Stream: 3 PRC for Signalled Lanes (%)	-2.9	Total Delay for Signalled Lanes (pcuHr):	12.12	Cycle Time (s):	60
C1	Stream: 4 PRC for Signalled Lanes (%)	33.0	Total Delay for Signalled Lanes (pcuHr):	4.41	Cycle Time (s):	60
	PRC Over All Lanes (%)	-2.9	Total Delay Over All Lanes(pcuHr):	34.61		

Basic Results Summary

Scenario 11: '2026 + Construction AM' (FG17: '2026 + Construction AM', Plan 1: 'Network Control Plan 1')

Network Layout Diagram

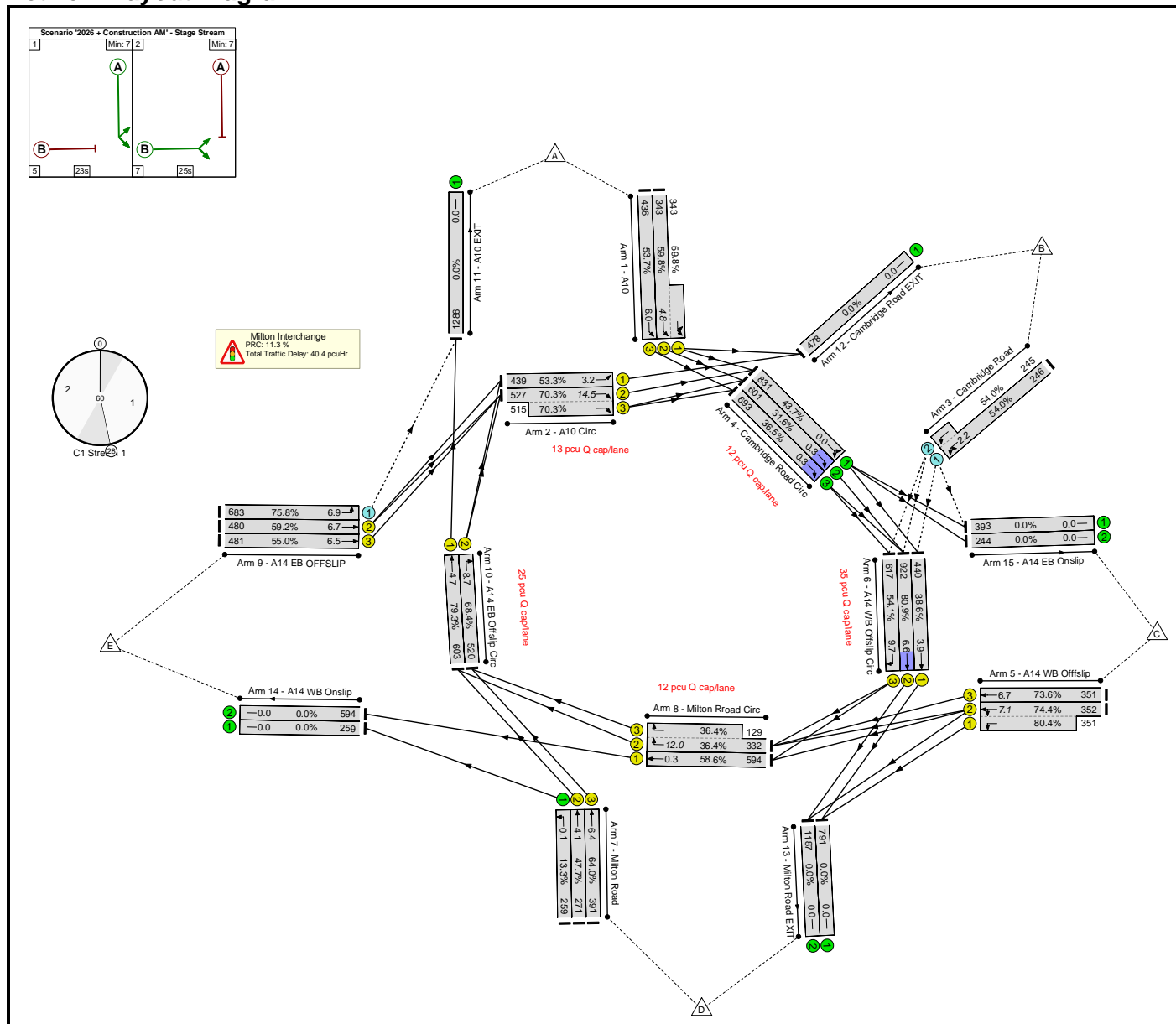

Basic Results Summary

Network Results

Item	Lane Description	Lane Type	Full Phase	Arrow Phase	Num Greens	Total Green (s)	Arrow Green (s)	Demand Flow (pcu)	Sat Flow (pcu/Hr)	Capacity (pcu)	Deg Sat (%)	Turners In Gaps (pcu)	Turners When Unopposed (pcu)	Turners In Intergreen (pcu)	Total Delay (pcuHr)	Av. Delay Per PCU (s/pcu)	Mean Max Queue (pcu)	Item
Network: Milton Interchange	-	-	-		-	-	-	-	-	-	80.9%	1223	442	0	40.4	-	-	Network: Milton Interchange
Milton Interchange	-	-	-		-	-	-	-	-	-	80.9%	1223	442	0	40.4	-	-	Milton Interchange
1/2+1/1	A10 Ahead Left	U	A		1	23	-	686	2057:1910	574+574	59.8 : 59.8%	-	-	-	3.2	17.0	4.8	1/2+1/1
1/3	A10 Ahead	U	A		1	23	-	436	2029	812	53.7%	-	-	-	2.2	18.5	6.0	1/3
2/1	A10 Circ Ahead	U	B		1	25	-	439	1900	823	53.3%	-	-	-	1.0	8.2	3.2	2/1
2/2+2/3	A10 Circ Right	U	B		1	25	-	1042	1900:1900	749+732	70.3 : 70.3%	-	-	-	4.3	14.9	14.5	2/2+2/3
3/1+3/2	Cambridge Road Left U-Turn	O	-		-	-	-	491	1828:1986	455+453	54.0 : 54.0%	982	0	0	0.9	6.3	2.2	3/1+3/2
4/1	Cambridge Road Circ Ahead Left	U	-		-	-	-	831	1900	1900	43.7%	-	-	-	0.0	0.0	0.0	4/1
4/2	Cambridge Road Circ Ahead	U	-		-	-	-	601	1900	1900	31.6%	-	-	-	0.0	0.1	0.3	4/2
4/3	Cambridge Road Circ Ahead	U	-		-	-	-	693	1900	1900	36.5%	-	-	-	0.0	0.2	0.3	4/3
5/2+5/1	A14 WB Offslip Ahead Left	U	C		1	13	-	703	2029:1871	473+437	74.4 : 80.4%	-	-	-	5.9	30.1	7.1	5/2+5/1
5/3	A14 WB Offslip Ahead	U	C		1	13	-	351	2044	477	73.6%	-	-	-	3.4	35.3	6.7	5/3
6/1	A14 WB Offslip Circ Ahead	U	D		1	35	-	440	1900	1140	38.6%	-	-	-	0.3	2.5	3.9	6/1
6/2	A14 WB Offslip Circ Ahead	U	D		1	35	-	922	1900	1140	80.9%	-	-	-	1.2	4.7	6.6	6/2

Basic Results Summary

6/3	A14 WB Offslip Circ Right	U	D		1	35	-	617	1900	1140	54.1%	-	-	-	1.8	10.7	9.7	6/3
7/1	Milton Road Left	U	-		-	-	-	259	1946	1946	13.3%	-	-	-	0.1	1.1	0.1	7/1
7/2	Milton Road Ahead	U	E		1	17	-	271	1894	568	47.7%	-	-	-	1.7	23.2	4.1	7/2
7/3	Milton Road Ahead	U	E		1	17	-	391	2037	611	64.0%	-	-	-	2.9	26.3	6.4	7/3
8/1	Milton Road Circ Ahead	U	F		1	31	-	594	1900	1013	58.6%	-	-	-	0.1	0.7	0.3	8/1
8/2+8/3	Milton Road Circ Right	U	F		1	31	-	461	1900:1900	913+355	36.4 : 36.4%	-	-	-	1.7	13.4	12.0	8/2+8/3
9/1	A14 EB OFFSLIP Left	O	-		-	-	-	683	1894	901	75.8%	241	442	0	1.8	9.5	6.9	9/1
9/2	A14 EB OFFSLIP Ahead	U	G		1	25	-	480	1871	811	59.2%	-	-	-	2.5	18.4	6.7	9/2
9/3	A14 EB OFFSLIP Ahead	U	G		1	25	-	481	2018	874	55.0%	-	-	-	2.3	17.2	6.5	9/3
10/1	A14 EB Offslip Circ Ahead	U	H		1	23	-	603	1900	760	79.3%	-	-	-	1.2	7.1	4.7	10/1
10/2	A14 EB Offslip Circ Right	U	H		1	23	-	520	1900	760	68.4%	-	-	-	1.7	12.1	8.7	10/2

C1	Stream: 1 PRC for Signalled Lanes (%)	28.0	Total Delay for Signalled Lanes (pcuHr):	10.79	Cycle Time (s):	60
C1	Stream: 2 PRC for Signalled Lanes (%)	11.3	Total Delay for Signalled Lanes (pcuHr):	12.64	Cycle Time (s):	60
C1	Stream: 3 PRC for Signalled Lanes (%)	40.7	Total Delay for Signalled Lanes (pcuHr):	6.44	Cycle Time (s):	60
C1	Stream: 4 PRC for Signalled Lanes (%)	13.4	Total Delay for Signalled Lanes (pcuHr):	7.68	Cycle Time (s):	60
	PRC Over All Lanes (%)	11.3	Total Delay Over All Lanes(pcuHr):	40.35		

Basic Results Summary

Scenario 12: '2026 + Construction PM' (FG18: '2026 + Construction PM', Plan 1: 'Network Control Plan 1')

Network Layout Diagram

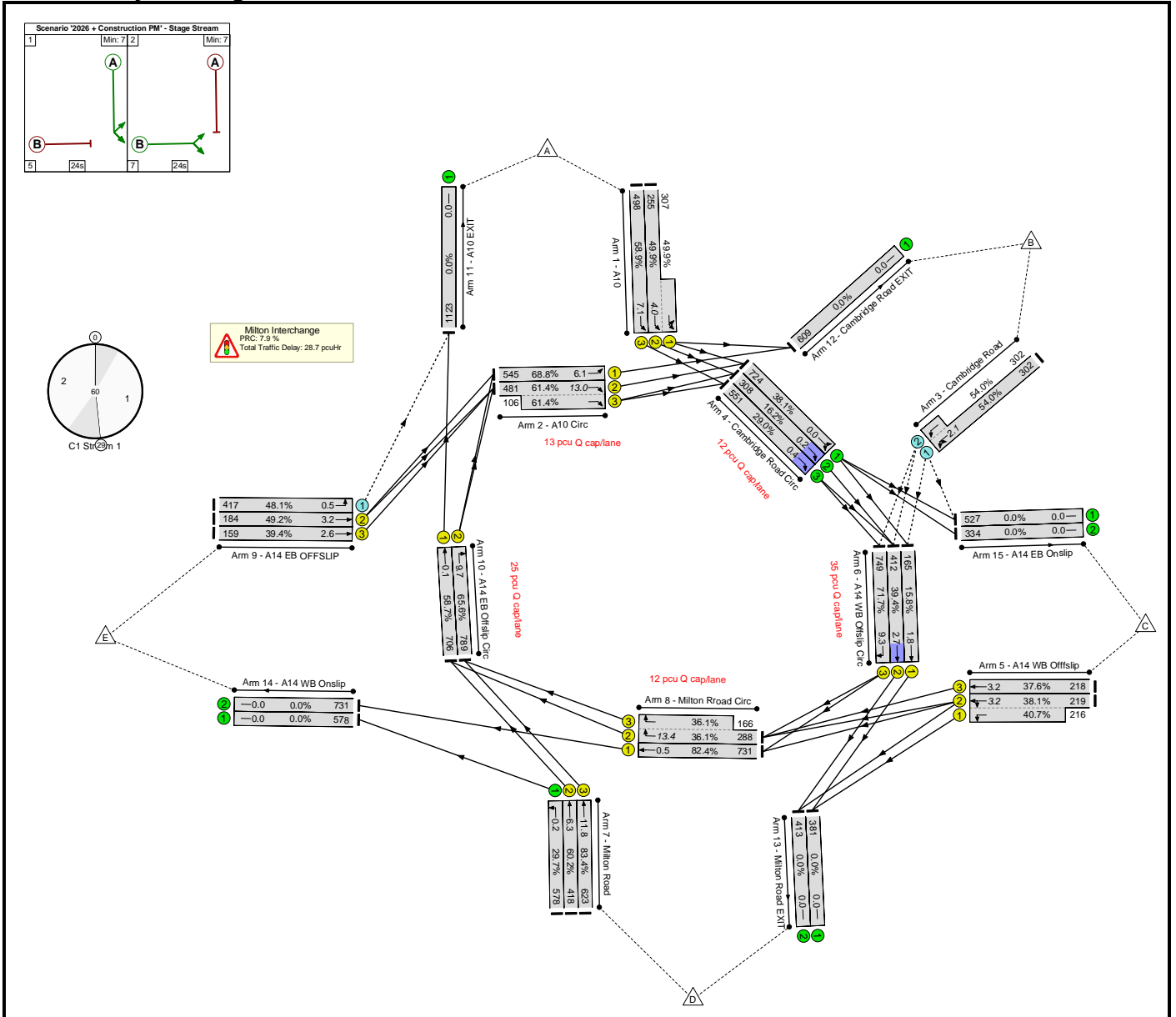

Basic Results Summary

Network Results

Item	Lane Description	Lane Type	Full Phase	Arrow Phase	Num Greens	Total Green (s)	Arrow Green (s)	Demand Flow (pcu)	Sat Flow (pcu/Hr)	Capacity (pcu)	Deg Sat (%)	Turners In Gaps (pcu)	Turners When Unopposed (pcu)	Turners In Intergreen (pcu)	Total Delay (pcuHr)	Av. Delay Per PCU (s/pcu)	Mean Max Queue (pcu)	Item
Network: Milton Interchange	-	-	-		-	-	-	-	-	-	83.4%	1472	153	0	28.7	-	-	Network: Milton Interchange
Milton Interchange	-	-	-		-	-	-	-	-	-	83.4%	1472	153	0	28.7	-	-	Milton Interchange
1/2+1/1	A10 Ahead Left	U	A		1	24	-	562	2057:1910	511+615	49.9 : 49.9%	-	-	-	2.4	15.1	4.0	1/2+1/1
1/3	A10 Ahead	U	A		1	24	-	498	2029	845	58.9%	-	-	-	2.6	18.7	7.1	1/3
2/1	A10 Circ Ahead	U	B		1	24	-	545	1900	792	68.8%	-	-	-	1.4	9.4	6.1	2/1
2/2+2/3	A10 Circ Right	U	B		1	24	-	587	1900:1900	784+173	61.4 : 61.4%	-	-	-	2.4	14.7	13.0	2/2+2/3
3/1+3/2	Cambridge Road Left U-Turn	O	-		-	-	-	604	1828:1986	559+559	54.0 : 54.0%	1208	0	0	0.7	4.3	2.1	3/1+3/2
4/1	Cambridge Road Circ Ahead Left	U	-		-	-	-	724	1900	1900	38.1%	-	-	-	0.0	0.0	0.0	4/1
4/2	Cambridge Road Circ Ahead	U	-		-	-	-	308	1900	1900	16.2%	-	-	-	0.0	0.1	0.2	4/2
4/3	Cambridge Road Circ Ahead	U	-		-	-	-	551	1900	1900	29.0%	-	-	-	0.0	0.3	0.4	4/3
5/2+5/1	A14 WB Offslip Ahead Left	U	C		1	16	-	435	2029:1871	575+530	38.1 : 40.7%	-	-	-	2.4	20.0	3.2	5/2+5/1
5/3	A14 WB Offslip Ahead	U	C		1	16	-	218	2044	579	37.6%	-	-	-	1.3	22.2	3.2	5/3
6/1	A14 WB Offslip Circ Ahead	U	D		1	32	-	165	1900	1045	15.8%	-	-	-	0.3	7.6	1.8	6/1
6/2	A14 WB Offslip Circ Ahead	U	D		1	32	-	412	1900	1045	39.4%	-	-	-	0.4	3.8	2.7	6/2

Basic Results Summary

6/3	A14 WB Offslip Circ Right	U	D		1	32	-	749	1900	1045	71.7%	-	-	-	0.6	3.1	9.3	6/3
7/1	Milton Road Left	U	-		-	-	-	578	1946	1946	29.7%	-	-	-	0.2	1.3	0.2	7/1
7/2	Milton Road Ahead	U	E		1	21	-	418	1894	694	60.2%	-	-	-	2.5	21.9	6.3	7/2
7/3	Milton Road Ahead	U	E		1	21	-	623	2037	747	83.4%	-	-	-	5.4	31.3	11.8	7/3
8/1	Milton Road Circ Ahead	U	F		1	27	-	731	1900	887	82.4%	-	-	-	0.3	1.3	0.5	8/1
8/2+8/3	Milton Road Circ Right	U	F		1	27	-	454	1900:1900	799+460	36.1 : 36.1%	-	-	-	2.1	17.0	13.4	8/2+8/3
9/1	A14 EB OFFSLIP Left	O	-		-	-	-	417	1894	867	48.1%	264	153	0	0.5	4.0	0.5	9/1
9/2	A14 EB OFFSLIP Ahead	U	G		1	11	-	184	1871	374	49.2%	-	-	-	1.6	30.7	3.2	9/2
9/3	A14 EB OFFSLIP Ahead	U	G		1	11	-	159	2018	404	39.4%	-	-	-	1.2	28.2	2.6	9/3
10/1	A14 EB Offslip Circ Ahead	U	H		1	37	-	706	1900	1203	58.7%	-	-	-	0.0	0.1	0.1	10/1
10/2	A14 EB Offslip Circ Right	U	H		1	37	-	789	1900	1203	65.6%	-	-	-	0.1	0.4	9.7	10/2

C1	Stream: 1 PRC for Signalled Lanes (%)	30.7	Total Delay for Signalled Lanes (pcuHr):	8.76	Cycle Time (s):	60
C1	Stream: 2 PRC for Signalled Lanes (%)	25.6	Total Delay for Signalled Lanes (pcuHr):	5.19	Cycle Time (s):	60
C1	Stream: 3 PRC for Signalled Lanes (%)	7.9	Total Delay for Signalled Lanes (pcuHr):	10.38	Cycle Time (s):	60
C1	Stream: 4 PRC for Signalled Lanes (%)	37.3	Total Delay for Signalled Lanes (pcuHr):	2.93	Cycle Time (s):	60
	PRC Over All Lanes (%)	7.9	Total Delay Over All Lanes(pcuHr):	28.69		

Basic Results Summary

Scenario 13: '2028 Decommissioning AM' (FG15: '2028 Decommissioning AM', Plan 1: 'Network Control Plan 1')

Network Layout Diagram

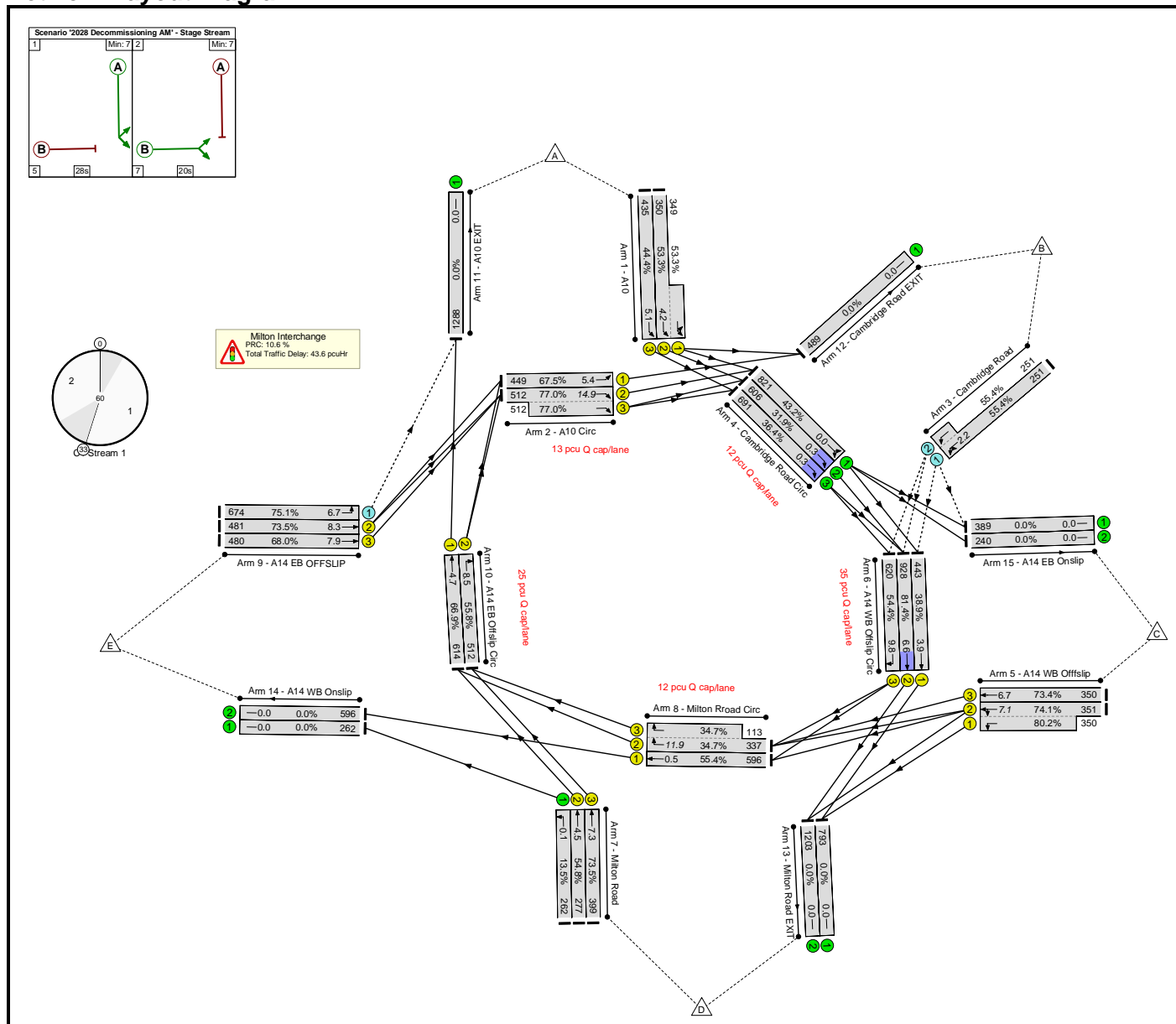

Basic Results Summary

Network Results

Item	Lane Description	Lane Type	Full Phase	Arrow Phase	Num Greens	Total Green (s)	Arrow Green (s)	Demand Flow (pcu)	Sat Flow (pcu/Hr)	Capacity (pcu)	Deg Sat (%)	Turners In Gaps (pcu)	Turners When Unopposed (pcu)	Turners In Intergreen (pcu)	Total Delay (pcuHr)	Av. Delay Per PCU (s/pcu)	Mean Max Queue (pcu)	Item
Network: Milton Interchange	-	-	-		-	-	-	-	-	-	81.4%	1330	348	0	43.6	-	-	Network: Milton Interchange
Milton Interchange	-	-	-		-	-	-	-	-	-	81.4%	1330	348	0	43.6	-	-	Milton Interchange
1/2+1/1	A10 Ahead Left	U	A		1	28	-	699	2057:1910	657+655	53.3 : 53.3%	-	-	-	2.5	12.7	4.2	1/2+1/1
1/3	A10 Ahead	U	A		1	28	-	435	2029	981	44.4%	-	-	-	1.6	13.5	5.1	1/3
2/1	A10 Circ Ahead	U	B		1	20	-	449	1900	665	67.5%	-	-	-	2.2	17.5	5.4	2/1
2/2+2/3	A10 Circ Right	U	B		1	20	-	1024	1900:1900	665+665	77.0 : 77.0%	-	-	-	3.9	13.8	14.9	2/2+2/3
3/1+3/2	Cambridge Road Left U-Turn	O	-		-	-	-	502	1828:1986	453+453	55.4 : 55.4%	1004	0	0	0.9	6.4	2.2	3/1+3/2
4/1	Cambridge Road Circ Ahead Left	U	-		-	-	-	821	1900	1900	43.2%	-	-	-	0.0	0.0	0.0	4/1
4/2	Cambridge Road Circ Ahead	U	-		-	-	-	606	1900	1900	31.9%	-	-	-	0.0	0.1	0.3	4/2
4/3	Cambridge Road Circ Ahead	U	-		-	-	-	691	1900	1900	36.4%	-	-	-	0.0	0.1	0.3	4/3
5/2+5/1	A14 WB Offslip Ahead Left	U	C		1	13	-	701	2029:1871	473+437	74.1 : 80.2%	-	-	-	5.8	30.0	7.1	5/2+5/1
5/3	A14 WB Offslip Ahead	U	C		1	13	-	350	2044	477	73.4%	-	-	-	3.4	35.2	6.7	5/3
6/1	A14 WB Offslip Circ Ahead	U	D		1	35	-	443	1900	1140	38.9%	-	-	-	0.4	3.3	3.9	6/1
6/2	A14 WB Offslip Circ Ahead	U	D		1	35	-	928	1900	1140	81.4%	-	-	-	1.5	6.0	6.6	6/2

Basic Results Summary

6/3	A14 WB Offslip Circ Right	U	D		1	35	-	620	1900	1140	54.4%	-	-	-	2.5	14.5	9.8	6/3
7/1	Milton Road Left	U	-		-	-	-	262	1946	1946	13.5%	-	-	-	0.1	1.1	0.1	7/1
7/2	Milton Road Ahead	U	E		1	15	-	277	1894	505	54.8%	-	-	-	2.1	26.8	4.5	7/2
7/3	Milton Road Ahead	U	E		1	15	-	399	2037	543	73.5%	-	-	-	3.6	32.3	7.3	7/3
8/1	Milton Road Circ Ahead	U	F		1	33	-	596	1900	1077	55.4%	-	-	-	0.0	0.2	0.5	8/1
8/2+8/3	Milton Road Circ Right	U	F		1	33	-	450	1900:1900	972+326	34.7 : 34.7%	-	-	-	1.8	14.3	11.9	8/2+8/3
9/1	A14 EB OFFSLIP Left	O	-		-	-	-	674	1894	897	75.1%	326	348	0	1.7	9.3	6.7	9/1
9/2	A14 EB OFFSLIP Ahead	U	G		1	20	-	481	1871	655	73.5%	-	-	-	3.6	27.3	8.3	9/2
9/3	A14 EB OFFSLIP Ahead	U	G		1	20	-	480	2018	706	68.0%	-	-	-	3.3	24.5	7.9	9/3
10/1	A14 EB Offslip Circ Ahead	U	H		1	28	-	614	1900	918	66.9%	-	-	-	1.0	6.0	4.7	10/1
10/2	A14 EB Offslip Circ Right	U	H		1	28	-	512	1900	918	55.8%	-	-	-	1.6	11.1	8.5	10/2
		C1	Stream: 1 PRC for Signalled Lanes (%)		16.9		Total Delay for Signalled Lanes (pcuHr):		10.19		Cycle Time (s):		60					
		C1	Stream: 2 PRC for Signalled Lanes (%)		10.6		Total Delay for Signalled Lanes (pcuHr):		13.71		Cycle Time (s):		60					
		C1	Stream: 3 PRC for Signalled Lanes (%)		22.5		Total Delay for Signalled Lanes (pcuHr):		7.47		Cycle Time (s):		60					
		C1	Stream: 4 PRC for Signalled Lanes (%)		22.5		Total Delay for Signalled Lanes (pcuHr):		9.51		Cycle Time (s):		60					
			PRC Over All Lanes (%)		10.6		Total Delay Over All Lanes(pcuHr):		43.63									

Basic Results Summary

Scenario 14: '2028 Decommissioning PM' (FG16: '2028 Decommissioning PM', Plan 1: 'Network Control Plan 1')

Network Layout Diagram

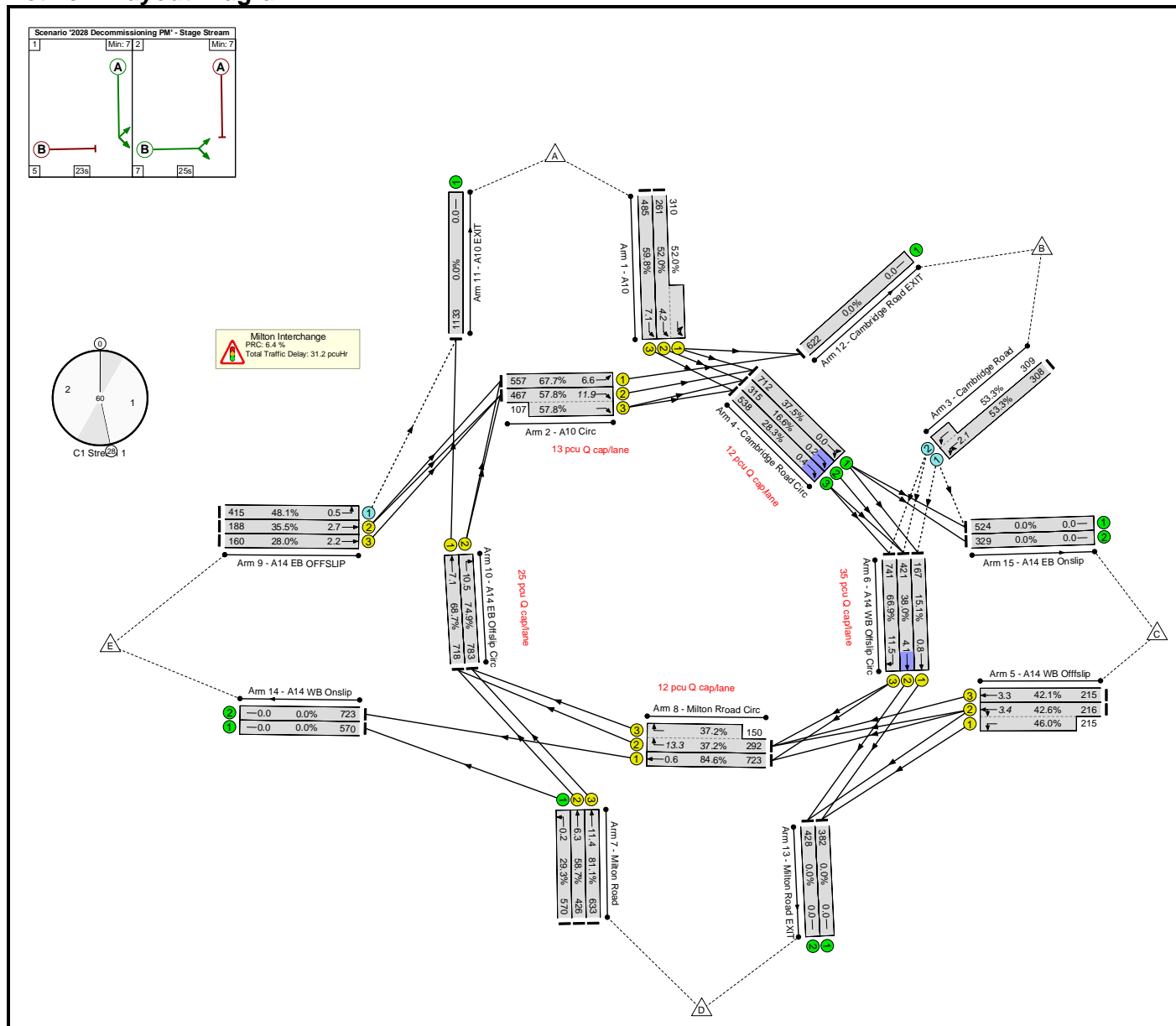

Basic Results Summary

Network Results

Item	Lane Description	Lane Type	Full Phase	Arrow Phase	Num Greens	Total Green (s)	Arrow Green (s)	Demand Flow (pcu)	Sat Flow (pcu/Hr)	Capacity (pcu)	Deg Sat (%)	Turners In Gaps (pcu)	Turners When Unopposed (pcu)	Turners In Intergreen (pcu)	Total Delay (pcuHr)	Av. Delay Per PCU (s/pcu)	Mean Max Queue (pcu)	Item
Network: Milton Interchange	-	-	-		-	-	-	-	-	-	84.6%	1462	187	0	31.2	-	-	Network: Milton Interchange
Milton Interchange	-	-	-		-	-	-	-	-	-	84.6%	1462	187	0	31.2	-	-	Milton Interchange
1/2+1/1	A10 Ahead Left	U	A		1	23	-	571	2057:1910	502+596	52.0 : 52.0%	-	-	-	2.5	16.1	4.2	1/2+1/1
1/3	A10 Ahead	U	A		1	23	-	485	2029	812	59.8%	-	-	-	2.7	19.7	7.1	1/3
2/1	A10 Circ Ahead	U	B		1	25	-	557	1900	823	67.7%	-	-	-	1.9	12.2	6.6	2/1
2/2+2/3	A10 Circ Right	U	B		1	25	-	574	1900:1900	809+185	57.8 : 57.8%	-	-	-	1.4	8.6	11.9	2/2+2/3
3/1+3/2	Cambridge Road Left U-Turn	O	-		-	-	-	617	1828:1986	578+580	53.3 : 53.3%	1234	0	0	0.7	4.4	2.1	3/1+3/2
4/1	Cambridge Road Circ Ahead Left	U	-		-	-	-	712	1900	1900	37.5%	-	-	-	0.0	0.0	0.0	4/1
4/2	Cambridge Road Circ Ahead	U	-		-	-	-	315	1900	1900	16.6%	-	-	-	0.0	0.1	0.2	4/2
4/3	Cambridge Road Circ Ahead	U	-		-	-	-	538	1900	1900	28.3%	-	-	-	0.0	0.3	0.4	4/3
5/2+5/1	A14 WB Offslip Ahead Left	U	C		1	14	-	431	2029:1871	507+468	42.6 : 46.0%	-	-	-	2.7	22.3	3.4	5/2+5/1
5/3	A14 WB Offslip Ahead	U	C		1	14	-	215	2044	511	42.1%	-	-	-	1.5	24.9	3.3	5/3
6/1	A14 WB Offslip Circ Ahead	U	D		1	34	-	167	1900	1108	15.1%	-	-	-	0.2	3.8	0.8	6/1
6/2	A14 WB Offslip Circ Ahead	U	D		1	34	-	421	1900	1108	38.0%	-	-	-	0.6	4.9	4.1	6/2

Basic Results Summary

6/3	A14 WB Offslip Circ Right	U	D		1	34	-	741	1900	1108	66.9%	-	-	-	2.1	10.0	11.5	6/3
7/1	Milton Road Left	U	-		-	-	-	570	1946	1946	29.3%	-	-	-	0.2	1.3	0.2	7/1
7/2	Milton Road Ahead	U	E		1	22	-	426	1894	726	58.7%	-	-	-	2.4	20.7	6.3	7/2
7/3	Milton Road Ahead	U	E		1	22	-	633	2037	781	81.1%	-	-	-	5.0	28.4	11.4	7/3
8/1	Milton Road Circ Ahead	U	F		1	26	-	723	1900	855	84.6%	-	-	-	0.3	1.4	0.6	8/1
8/2+8/3	Milton Road Circ Right	U	F		1	26	-	442	1900:1900	785+403	37.2 : 37.2%	-	-	-	1.8	14.6	13.3	8/2+8/3
9/1	A14 EB OFFSLIP Left	O	-		-	-	-	415	1894	863	48.1%	228	187	0	0.5	4.0	0.5	9/1
9/2	A14 EB OFFSLIP Ahead	U	G		1	16	-	188	1871	530	35.5%	-	-	-	1.2	22.4	2.7	9/2
9/3	A14 EB OFFSLIP Ahead	U	G		1	16	-	160	2018	572	28.0%	-	-	-	0.9	21.1	2.2	9/3
10/1	A14 EB Offslip Circ Ahead	U	H		1	32	-	718	1900	1045	68.7%	-	-	-	1.0	5.0	7.1	10/1
10/2	A14 EB Offslip Circ Right	U	H		1	32	-	783	1900	1045	74.9%	-	-	-	1.7	7.6	10.5	10/2

C1	Stream: 1 PRC for Signalled Lanes (%)	33.0	Total Delay for Signalled Lanes (pcuHr):	8.46	Cycle Time (s):	60
C1	Stream: 2 PRC for Signalled Lanes (%)	34.6	Total Delay for Signalled Lanes (pcuHr):	6.96	Cycle Time (s):	60
C1	Stream: 3 PRC for Signalled Lanes (%)	6.4	Total Delay for Signalled Lanes (pcuHr):	9.51	Cycle Time (s):	60
C1	Stream: 4 PRC for Signalled Lanes (%)	20.1	Total Delay for Signalled Lanes (pcuHr):	4.77	Cycle Time (s):	60
	PRC Over All Lanes (%)	6.4	Total Delay Over All Lanes(pcuHr):	31.18		

Basic Results Summary

Scenario 15: '2033 + Operation AM' (FG11: '2033 + Operation AM', Plan 1: 'Network Control Plan 1')

Network Layout Diagram

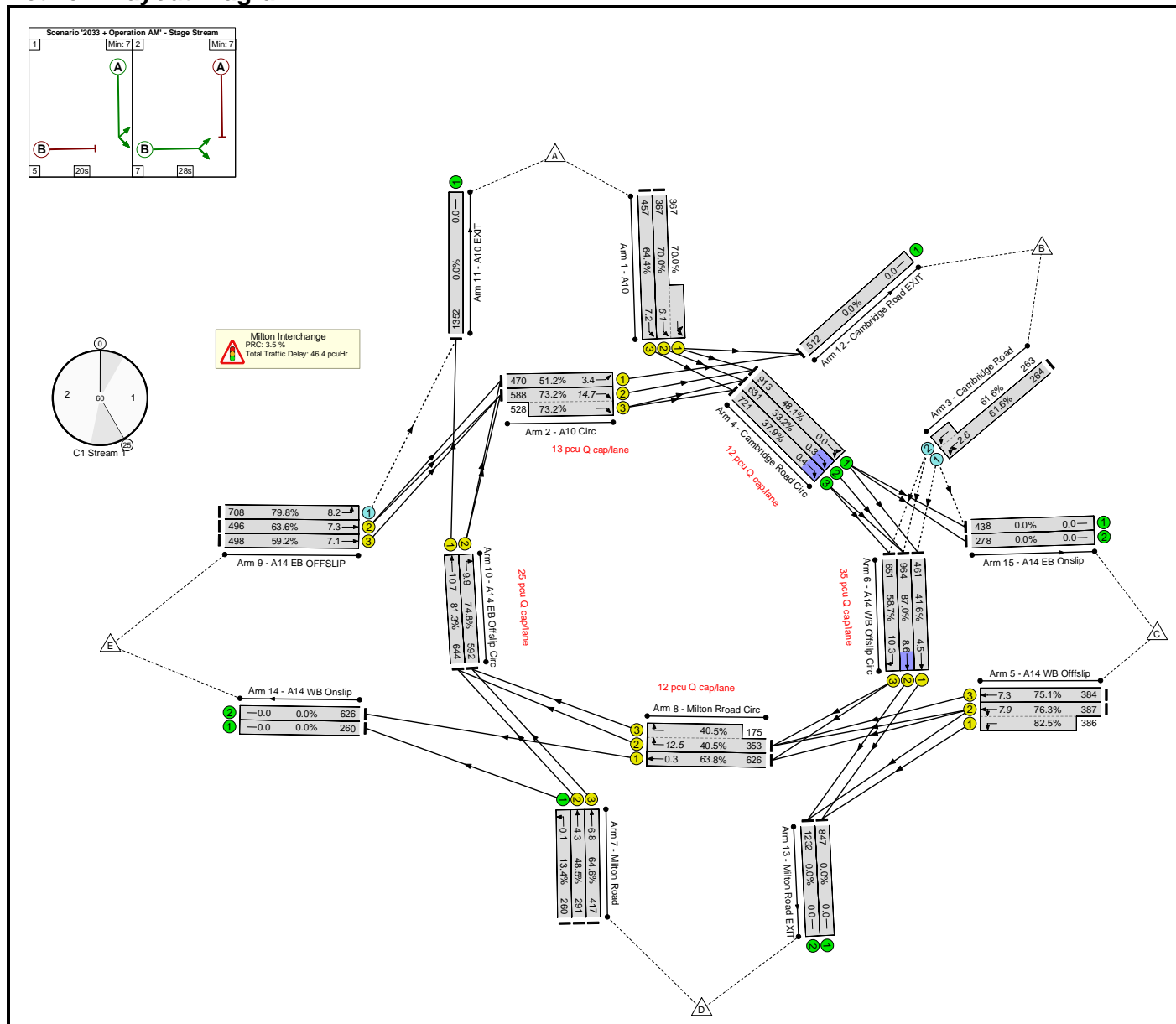

Basic Results Summary

Network Results

Item	Lane Description	Lane Type	Full Phase	Arrow Phase	Num Greens	Total Green (s)	Arrow Green (s)	Demand Flow (pcu)	Sat Flow (pcu/Hr)	Capacity (pcu)	Deg Sat (%)	Turners In Gaps (pcu)	Turners When Unopposed (pcu)	Turners In Intergreen (pcu)	Total Delay (pcuHr)	Av. Delay Per PCU (s/pcu)	Mean Max Queue (pcu)	Item
Network: Milton Interchange	-	-	-		-	-	-	-	-	-	87.0%	1300	462	0	46.4	-	-	Network: Milton Interchange
Milton Interchange	-	-	-		-	-	-	-	-	-	87.0%	1300	462	0	46.4	-	-	Milton Interchange
1/2+1/1	A10 Ahead Left	U	A		1	20	-	734	2057:1910	524+524	70.0 : 70.0%	-	-	-	4.3	21.3	6.1	1/2+1/1
1/3	A10 Ahead	U	A		1	20	-	457	2029	710	64.4%	-	-	-	3.0	23.4	7.2	1/3
2/1	A10 Circ Ahead	U	B		1	28	-	470	1900	918	51.2%	-	-	-	0.9	6.6	3.4	2/1
2/2+2/3	A10 Circ Right	U	B		1	28	-	1116	1900:1900	804+722	73.2 : 73.2%	-	-	-	3.9	12.5	14.7	2/2+2/3
3/1+3/2	Cambridge Road Left U-Turn	O	-		-	-	-	527	1828:1986	428+427	61.6 : 61.6%	1054	0	0	1.1	7.7	2.6	3/1+3/2
4/1	Cambridge Road Circ Ahead Left	U	-		-	-	-	913	1900	1900	48.1%	-	-	-	0.0	0.0	0.0	4/1
4/2	Cambridge Road Circ Ahead	U	-		-	-	-	631	1900	1900	33.2%	-	-	-	0.0	0.2	0.3	4/2
4/3	Cambridge Road Circ Ahead	U	-		-	-	-	721	1900	1900	37.9%	-	-	-	0.0	0.2	0.4	4/3
5/2+5/1	A14 WB Offslip Ahead Left	U	C		1	14	-	773	2029:1871	507+468	76.3 : 82.5%	-	-	-	6.4	29.8	7.9	5/2+5/1
5/3	A14 WB Offslip Ahead	U	C		1	14	-	384	2044	511	75.1%	-	-	-	3.7	34.6	7.3	5/3
6/1	A14 WB Offslip Circ Ahead	U	D		1	34	-	461	1900	1108	41.6%	-	-	-	0.3	2.1	4.5	6/1
6/2	A14 WB Offslip Circ Ahead	U	D		1	34	-	964	1900	1108	87.0%	-	-	-	1.8	6.6	8.6	6/2

Basic Results Summary

6/3	A14 WB Offslip Circ Right	U	D		1	34	-	651	1900	1108	58.7%	-	-	-	1.5	8.5	10.3	6/3
7/1	Milton Road Left	U	-		-	-	-	260	1946	1946	13.4%	-	-	-	0.1	1.1	0.1	7/1
7/2	Milton Road Ahead	U	E		1	18	-	291	1894	600	48.5%	-	-	-	1.8	22.4	4.3	7/2
7/3	Milton Road Ahead	U	E		1	18	-	417	2037	645	64.6%	-	-	-	2.9	25.5	6.8	7/3
8/1	Milton Road Circ Ahead	U	F		1	30	-	626	1900	982	63.8%	-	-	-	0.1	0.8	0.3	8/1
8/2+8/3	Milton Road Circ Right	U	F		1	30	-	528	1900:1900	872+432	40.5 : 40.5%	-	-	-	2.1	14.1	12.5	8/2+8/3
9/1	A14 EB OFFSLIP Left	O	-		-	-	-	708	1894	887	79.8%	246	462	0	2.3	11.7	8.2	9/1
9/2	A14 EB OFFSLIP Ahead	U	G		1	24	-	496	1871	780	63.6%	-	-	-	2.8	20.2	7.3	9/2
9/3	A14 EB OFFSLIP Ahead	U	G		1	24	-	498	2018	841	59.2%	-	-	-	2.6	18.8	7.1	9/3
10/1	A14 EB Offslip Circ Ahead	U	H		1	24	-	644	1900	792	81.3%	-	-	-	2.1	11.7	10.7	10/1
10/2	A14 EB Offslip Circ Right	U	H		1	24	-	592	1900	792	74.8%	-	-	-	2.7	16.5	9.9	10/2
		C1	Stream: 1 PRC for Signalled Lanes (%)				23.0	Total Delay for Signalled Lanes (pcuHr):		12.04		Cycle Time (s):		60				
		C1	Stream: 2 PRC for Signalled Lanes (%)				3.5	Total Delay for Signalled Lanes (pcuHr):		13.66		Cycle Time (s):		60				
		C1	Stream: 3 PRC for Signalled Lanes (%)				39.2	Total Delay for Signalled Lanes (pcuHr):		6.96		Cycle Time (s):		60				
		C1	Stream: 4 PRC for Signalled Lanes (%)				10.6	Total Delay for Signalled Lanes (pcuHr):		10.19		Cycle Time (s):		60				
				PRC Over All Lanes (%)		3.5		Total Delay Over All Lanes(pcuHr):		46.41								

Basic Results Summary

Scenario 16: '2033 + Operation PM' (FG12: '2033 + Operation PM', Plan 1: 'Network Control Plan 1')

Network Layout Diagram

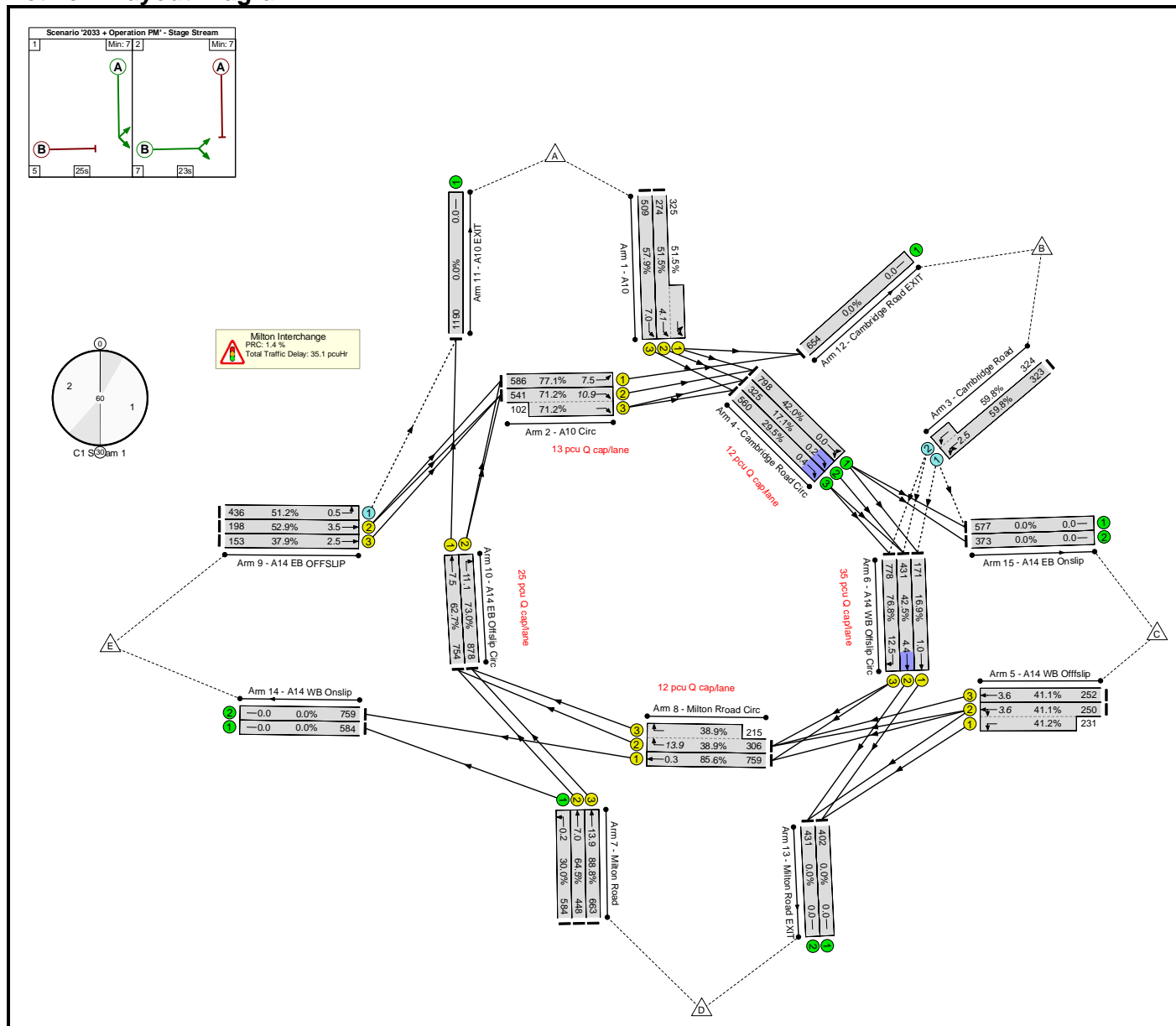

Basic Results Summary

Network Results

Item	Lane Description	Lane Type	Full Phase	Arrow Phase	Num Greens	Total Green (s)	Arrow Green (s)	Demand Flow (pcu)	Sat Flow (pcu/Hr)	Capacity (pcu)	Deg Sat (%)	Turners In Gaps (pcu)	Turners When Unopposed (pcu)	Turners In Intergreen (pcu)	Total Delay (pcuHr)	Av. Delay Per PCU (s/pcu)	Mean Max Queue (pcu)	Item
Network: Milton Interchange	-	-	-		-	-	-	-	-	-	88.8%	1570	160	0	35.1	-	-	Network: Milton Interchange
Milton Interchange	-	-	-		-	-	-	-	-	-	88.8%	1570	160	0	35.1	-	-	Milton Interchange
1/2+1/1	A10 Ahead Left	U	A		1	25	-	599	2057:1910	532+631	51.5 : 51.5%	-	-	-	2.4	14.6	4.1	1/2+1/1
1/3	A10 Ahead	U	A		1	25	-	509	2029	879	57.9%	-	-	-	2.5	17.7	7.0	1/3
2/1	A10 Circ Ahead	U	B		1	23	-	586	1900	760	77.1%	-	-	-	1.9	11.6	7.5	2/1
2/2+2/3	A10 Circ Right	U	B		1	23	-	643	1900:1900	760+143	71.2 : 71.2%	-	-	-	1.3	7.2	10.9	2/2+2/3
3/1+3/2	Cambridge Road Left U-Turn	O	-		-	-	-	647	1828:1986	540+542	59.8 : 59.8%	1294	0	0	0.9	5.3	2.5	3/1+3/2
4/1	Cambridge Road Circ Ahead Left	U	-		-	-	-	798	1900	1900	42.0%	-	-	-	0.0	0.0	0.0	4/1
4/2	Cambridge Road Circ Ahead	U	-		-	-	-	325	1900	1900	17.1%	-	-	-	0.0	0.1	0.2	4/2
4/3	Cambridge Road Circ Ahead	U	-		-	-	-	560	1900	1900	29.5%	-	-	-	0.0	0.3	0.4	4/3
5/2+5/1	A14 WB Offslip Ahead Left	U	C		1	17	-	481	2029:1871	609+561	41.1 : 41.2%	-	-	-	2.6	19.4	3.6	5/2+5/1
5/3	A14 WB Offslip Ahead	U	C		1	17	-	252	2044	613	41.1%	-	-	-	1.5	21.7	3.6	5/3
6/1	A14 WB Offslip Circ Ahead	U	D		1	31	-	171	1900	1013	16.9%	-	-	-	0.2	4.9	1.0	6/1
6/2	A14 WB Offslip Circ Ahead	U	D		1	31	-	431	1900	1013	42.5%	-	-	-	0.7	5.7	4.4	6/2

Basic Results Summary

6/3	A14 WB Offslip Circ Right	U	D		1	31	-	778	1900	1013	76.8%	-	-	-	2.5	11.7	12.5	6/3
7/1	Milton Road Left	U	-		-	-	-	584	1946	1946	30.0%	-	-	-	0.2	1.3	0.2	7/1
7/2	Milton Road Ahead	U	E		1	21	-	448	1894	694	64.5%	-	-	-	2.9	23.0	7.0	7/2
7/3	Milton Road Ahead	U	E		1	21	-	663	2037	747	88.8%	-	-	-	6.9	37.6	13.9	7/3
8/1	Milton Road Circ Ahead	U	F		1	27	-	759	1900	887	85.6%	-	-	-	0.1	0.7	0.3	8/1
8/2+8/3	Milton Road Circ Right	U	F		1	27	-	521	1900:1900	786+552	38.9 : 38.9%	-	-	-	2.6	17.9	13.9	8/2+8/3
9/1	A14 EB OFFSLIP Left	O	-		-	-	-	436	1894	851	51.2%	276	160	0	0.5	4.3	0.5	9/1
9/2	A14 EB OFFSLIP Ahead	U	G		1	11	-	198	1871	374	52.9%	-	-	-	1.7	31.6	3.5	9/2
9/3	A14 EB OFFSLIP Ahead	U	G		1	11	-	153	2018	404	37.9%	-	-	-	1.2	27.9	2.5	9/3
10/1	A14 EB Offslip Circ Ahead	U	H		1	37	-	754	1900	1203	62.7%	-	-	-	0.9	4.1	7.5	10/1
10/2	A14 EB Offslip Circ Right	U	H		1	37	-	878	1900	1203	73.0%	-	-	-	1.4	5.8	11.1	10/2

C1	Stream: 1 PRC for Signalled Lanes (%)	16.7	Total Delay for Signalled Lanes (pcuHr):	8.09	Cycle Time (s):	60
C1	Stream: 2 PRC for Signalled Lanes (%)	17.2	Total Delay for Signalled Lanes (pcuHr):	7.54	Cycle Time (s):	60
C1	Stream: 3 PRC for Signalled Lanes (%)	1.4	Total Delay for Signalled Lanes (pcuHr):	12.53	Cycle Time (s):	60
C1	Stream: 4 PRC for Signalled Lanes (%)	23.3	Total Delay for Signalled Lanes (pcuHr):	5.18	Cycle Time (s):	60
	PRC Over All Lanes (%)	1.4	Total Delay Over All Lanes(pcuHr):	35.09		

Basic Results Summary

Scenario 17: '2038 + Operation AM' (FG13: '2038 + Operation AM', Plan 1: 'Network Control Plan 1')

Network Layout Diagram

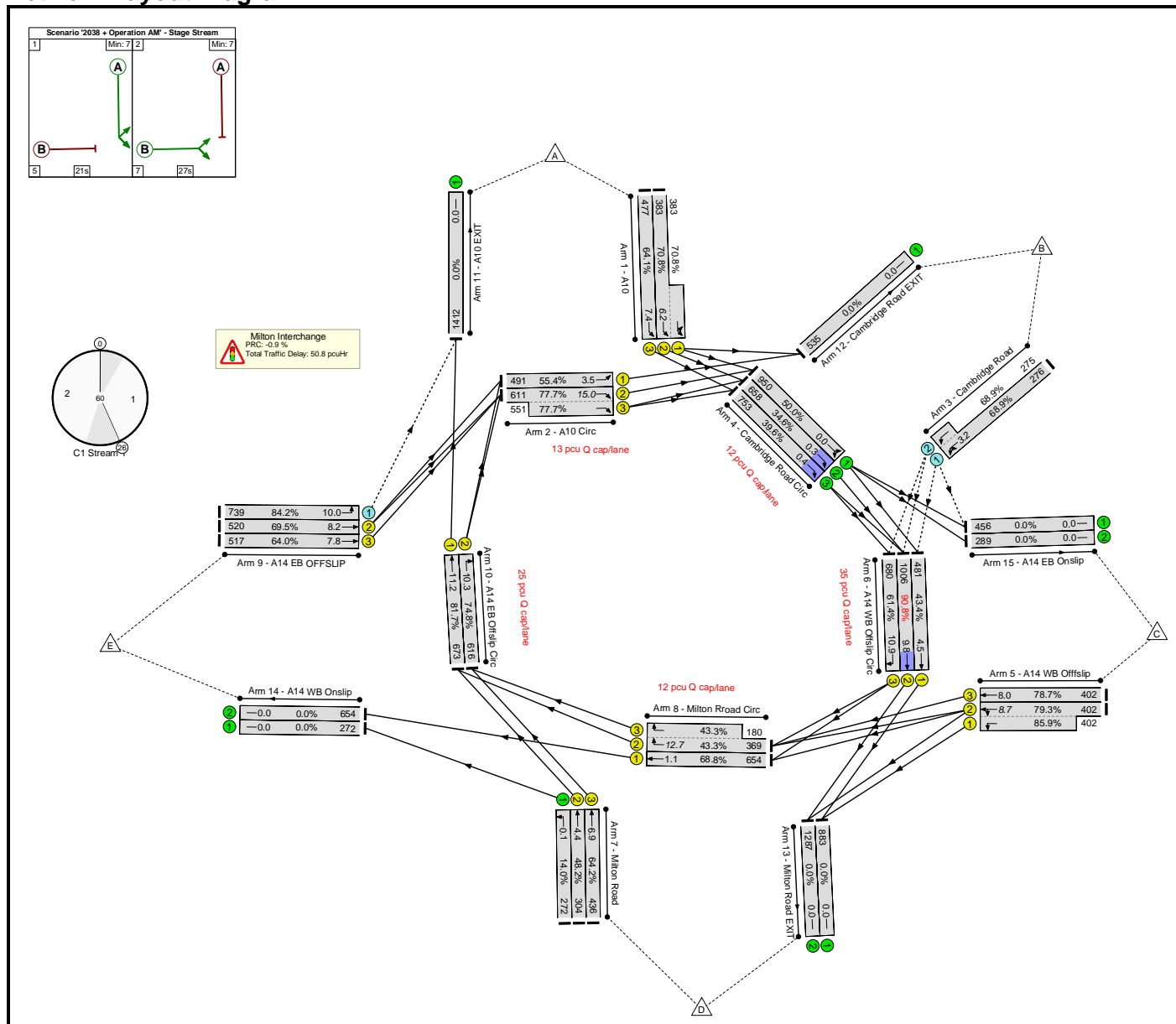

Basic Results Summary

Network Results

Item	Lane Description	Lane Type	Full Phase	Arrow Phase	Num Greens	Total Green (s)	Arrow Green (s)	Demand Flow (pcu)	Sat Flow (pcu/Hr)	Capacity (pcu)	Deg Sat (%)	Turners In Gaps (pcu)	Turners When Unopposed (pcu)	Turners In Intergreen (pcu)	Total Delay (pcuHr)	Av. Delay Per PCU (s/pcu)	Mean Max Queue (pcu)	Item
Network: Milton Interchange	-	-	-		-	-	-	-	-	-	90.8%	1356	485	0	50.8	-	-	Network: Milton Interchange
Milton Interchange	-	-	-		-	-	-	-	-	-	90.8%	1356	485	0	50.8	-	-	Milton Interchange
1/2+1/1	A10 Ahead Left	U	A		1	21	-	766	2057:1910	541+541	70.8 : 70.8%	-	-	-	4.4	20.6	6.2	1/2+1/1
1/3	A10 Ahead	U	A		1	21	-	477	2029	744	64.1%	-	-	-	3.0	22.4	7.4	1/3
2/1	A10 Circ Ahead	U	B		1	27	-	491	1900	887	55.4%	-	-	-	1.0	7.0	3.5	2/1
2/2+2/3	A10 Circ Right	U	B		1	27	-	1162	1900:1900	787+709	77.7 : 77.7%	-	-	-	4.3	13.3	15.0	2/2+2/3
3/1+3/2	Cambridge Road Left U-Turn	O	-		-	-	-	551	1828:1986	400+399	68.9 : 68.9%	1102	0	0	1.6	10.1	3.2	3/1+3/2
4/1	Cambridge Road Circ Ahead Left	U	-		-	-	-	950	1900	1900	50.0%	-	-	-	0.0	0.0	0.0	4/1
4/2	Cambridge Road Circ Ahead	U	-		-	-	-	658	1900	1900	34.6%	-	-	-	0.0	0.2	0.3	4/2
4/3	Cambridge Road Circ Ahead	U	-		-	-	-	753	1900	1900	39.6%	-	-	-	0.0	0.2	0.4	4/3
5/2+5/1	A14 WB Offslip Ahead Left	U	C		1	14	-	804	2029:1871	507+468	79.3 : 85.9%	-	-	-	7.0	31.5	8.7	5/2+5/1
5/3	A14 WB Offslip Ahead	U	C		1	14	-	402	2044	511	78.7%	-	-	-	4.1	37.0	8.0	5/3
6/1	A14 WB Offslip Circ Ahead	U	D		1	34	-	481	1900	1108	43.4%	-	-	-	0.3	2.1	4.5	6/1
6/2	A14 WB Offslip Circ Ahead	U	D		1	34	-	1006	1900	1108	90.8%	-	-	-	2.4	8.4	9.8	6/2

Basic Results Summary

6/3	A14 WB Offslip Circ Right	U	D		1	34	-	680	1900	1108	61.4%	-	-	-	1.6	8.7	10.9	6/3
7/1	Milton Road Left	U	-		-	-	-	272	1946	1946	14.0%	-	-	-	0.1	1.1	0.1	7/1
7/2	Milton Road Ahead	U	E		1	19	-	304	1894	631	48.2%	-	-	-	1.8	21.4	4.4	7/2
7/3	Milton Road Ahead	U	E		1	19	-	436	2037	679	64.2%	-	-	-	2.9	24.3	6.9	7/3
8/1	Milton Road Circ Ahead	U	F		1	29	-	654	1900	950	68.8%	-	-	-	0.1	0.4	1.1	8/1
8/2+8/3	Milton Road Circ Right	U	F		1	29	-	549	1900:1900	852+415	43.3 : 43.3%	-	-	-	2.3	15.0	12.7	8/2+8/3
9/1	A14 EB OFFSLIP Left	O	-		-	-	-	739	1894	878	84.2%	254	485	0	3.1	14.9	10.0	9/1
9/2	A14 EB OFFSLIP Ahead	U	G		1	23	-	520	1871	748	69.5%	-	-	-	3.3	22.8	8.2	9/2
9/3	A14 EB OFFSLIP Ahead	U	G		1	23	-	517	2018	807	64.0%	-	-	-	3.0	20.7	7.8	9/3
10/1	A14 EB Offslip Circ Ahead	U	H		1	25	-	673	1900	823	81.7%	-	-	-	1.9	10.4	11.2	10/1
10/2	A14 EB Offslip Circ Right	U	H		1	25	-	616	1900	823	74.8%	-	-	-	2.6	15.4	10.3	10/2

C1	Stream: 1 PRC for Signalled Lanes (%)	15.9	Total Delay for Signalled Lanes (pcuHr):	12.62	Cycle Time (s):	60
C1	Stream: 2 PRC for Signalled Lanes (%)	-0.9	Total Delay for Signalled Lanes (pcuHr):	15.46	Cycle Time (s):	60
C1	Stream: 3 PRC for Signalled Lanes (%)	30.7	Total Delay for Signalled Lanes (pcuHr):	7.12	Cycle Time (s):	60
C1	Stream: 4 PRC for Signalled Lanes (%)	10.1	Total Delay for Signalled Lanes (pcuHr):	10.83	Cycle Time (s):	60
	PRC Over All Lanes (%)	-0.9	Total Delay Over All Lanes (pcuHr):	50.78		

Basic Results Summary

Scenario 18: '2038 + Operation PM' (FG14: '2038 + Operation PM', Plan 1: 'Network Control Plan 1')

Network Layout Diagram

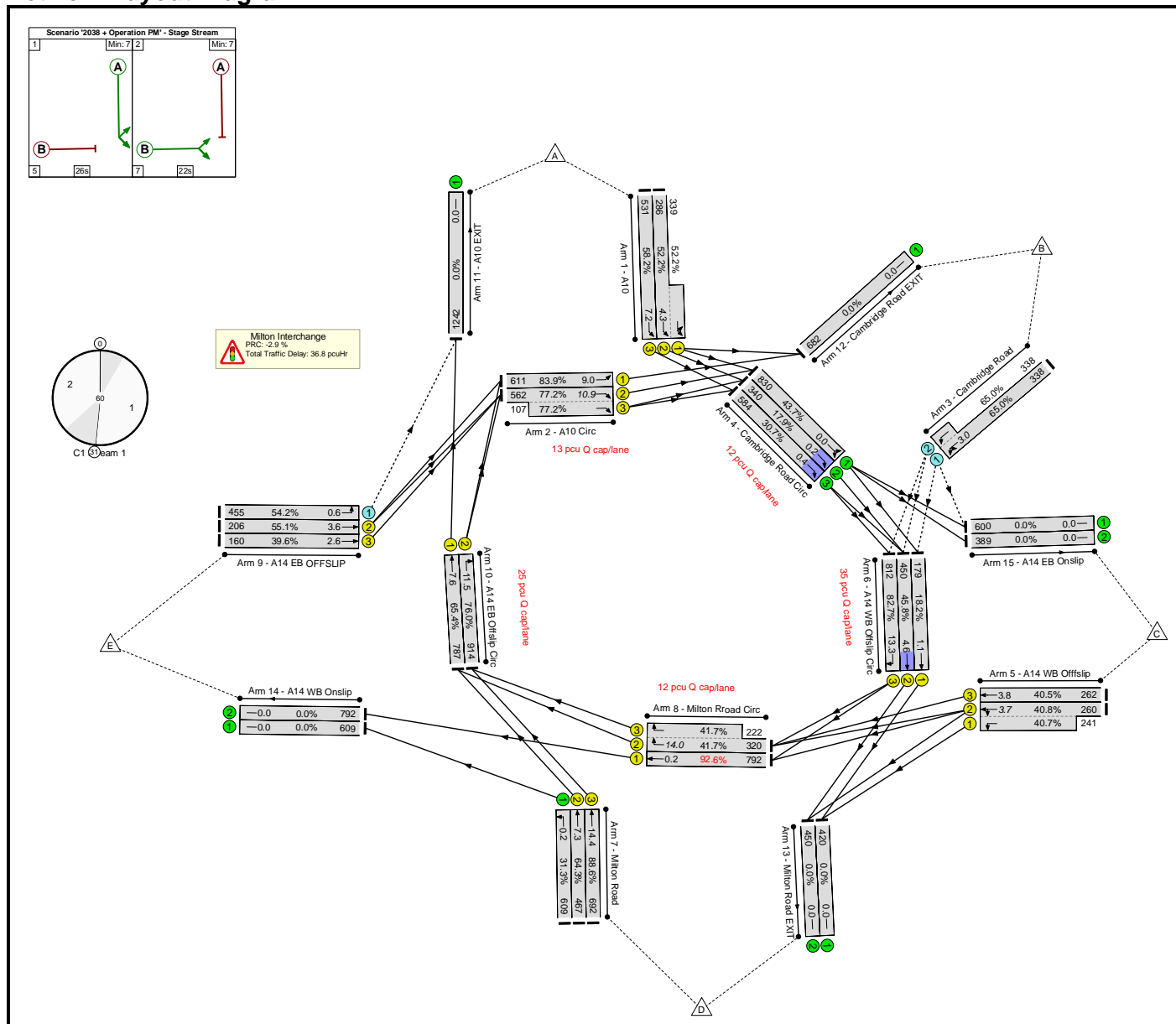

Basic Results Summary

Network Results

Item	Lane Description	Lane Type	Full Phase	Arrow Phase	Num Greens	Total Green (s)	Arrow Green (s)	Demand Flow (pcu)	Sat Flow (pcu/Hr)	Capacity (pcu)	Deg Sat (%)	Turners In Gaps (pcu)	Turners When Unopposed (pcu)	Turners In Intergreen (pcu)	Total Delay (pcuHr)	Av. Delay Per PCU (s/pcu)	Mean Max Queue (pcu)	Item
Network: Milton Interchange	-	-	-		-	-	-	-	-	-	92.6%	1640	167	0	36.8	-	-	Network: Milton Interchange
Milton Interchange	-	-	-		-	-	-	-	-	-	92.6%	1640	167	0	36.8	-	-	Milton Interchange
1/2+1/1	A10 Ahead Left	U	A		1	26	-	625	2057:1910	548+649	52.2 : 52.2%	-	-	-	2.4	14.0	4.3	1/2+1/1
1/3	A10 Ahead	U	A		1	26	-	531	2029	913	58.2%	-	-	-	2.5	17.0	7.2	1/3
2/1	A10 Circ Ahead	U	B		1	22	-	611	1900	728	83.9%	-	-	-	2.1	12.4	9.0	2/1
2/2+2/3	A10 Circ Right	U	B		1	22	-	669	1900:1900	728+139	77.2 : 77.2%	-	-	-	1.5	8.0	10.9	2/2+2/3
3/1+3/2	Cambridge Road Left U-Turn	O	-		-	-	-	676	1828:1986	520+520	65.0 : 65.0%	1352	0	0	1.2	6.3	3.0	3/1+3/2
4/1	Cambridge Road Circ Ahead Left	U	-		-	-	-	830	1900	1900	43.7%	-	-	-	0.0	0.0	0.0	4/1
4/2	Cambridge Road Circ Ahead	U	-		-	-	-	340	1900	1900	17.9%	-	-	-	0.0	0.1	0.2	4/2
4/3	Cambridge Road Circ Ahead	U	-		-	-	-	584	1900	1900	30.7%	-	-	-	0.0	0.3	0.4	4/3
5/2+5/1	A14 WB Offslip Ahead Left	U	C		1	18	-	501	2029:1871	637+592	40.8 : 40.7%	-	-	-	2.6	18.5	3.7	5/2+5/1
5/3	A14 WB Offslip Ahead	U	C		1	18	-	262	2044	647	40.5%	-	-	-	1.5	20.7	3.8	5/3
6/1	A14 WB Offslip Circ Ahead	U	D		1	30	-	179	1900	982	18.2%	-	-	-	0.3	5.3	1.1	6/1
6/2	A14 WB Offslip Circ Ahead	U	D		1	30	-	450	1900	982	45.8%	-	-	-	0.8	6.2	4.6	6/2

Basic Results Summary

6/3	A14 WB Offslip Circ Right	U	D		1	30	-	812	1900	982	82.7%	-	-	-	2.9	12.8	13.3	6/3
7/1	Milton Road Left	U	-		-	-	-	609	1946	1946	31.3%	-	-	-	0.2	1.3	0.2	7/1
7/2	Milton Road Ahead	U	E		1	22	-	467	1894	726	64.3%	-	-	-	2.9	22.0	7.3	7/2
7/3	Milton Road Ahead	U	E		1	22	-	692	2037	781	88.6%	-	-	-	6.9	36.0	14.4	7/3
8/1	Milton Road Circ Ahead	U	F		1	26	-	792	1900	855	92.6%	-	-	-	0.1	0.5	0.2	8/1
8/2+8/3	Milton Road Circ Right	U	F		1	26	-	542	1900:1900	768+533	41.7 : 41.7%	-	-	-	2.8	18.9	14.0	8/2+8/3
9/1	A14 EB OFFSLIP Left	O	-		-	-	-	455	1894	840	54.2%	288	167	0	0.6	4.7	0.6	9/1
9/2	A14 EB OFFSLIP Ahead	U	G		1	11	-	206	1871	374	55.1%	-	-	-	1.8	32.2	3.6	9/2
9/3	A14 EB OFFSLIP Ahead	U	G		1	11	-	160	2018	404	39.6%	-	-	-	1.3	28.2	2.6	9/3
10/1	A14 EB Offslip Circ Ahead	U	H		1	37	-	787	1900	1203	65.4%	-	-	-	0.9	3.9	7.6	10/1
10/2	A14 EB Offslip Circ Right	U	H		1	37	-	914	1900	1203	76.0%	-	-	-	1.5	5.8	11.5	10/2

C1	Stream: 1 PRC for Signalled Lanes (%)	7.3	Total Delay for Signalled Lanes (pcuHr):	8.52	Cycle Time (s):	60
C1	Stream: 2 PRC for Signalled Lanes (%)	8.8	Total Delay for Signalled Lanes (pcuHr):	8.03	Cycle Time (s):	60
C1	Stream: 3 PRC for Signalled Lanes (%)	-2.9	Total Delay for Signalled Lanes (pcuHr):	12.74	Cycle Time (s):	60
C1	Stream: 4 PRC for Signalled Lanes (%)	18.5	Total Delay for Signalled Lanes (pcuHr):	5.43	Cycle Time (s):	60
	PRC Over All Lanes (%)	-2.9	Total Delay Over All Lanes (pcuHr):	36.76		

6 Milton Road / Cowley Road (LinSig)

- 2021 Baseline AM
- 2021 Baseline PM
- Construction Year 3 (2026) – Future Baseline AM
- Construction Year 3 (2026) – Future Baseline PM
- Construction Year 5 (2028) – Future Baseline AM
- Construction Year 5 (2028) – Future Baseline PM
- Construction Year 3 (2026) – Construction Peak AM
- Construction Year 3 (2026) – Construction Peak PM
- Construction Year 5 (2028) – Decommissioning AM
- Construction Year 5 (2028) – Decommissioning PM

Basic Results Summary
Basic Results Summary

User and Project Details

Project:	100102041 – AWS Cambridge WWTPRP
Title:	Milton Road/Cowley Road
Location:	
Client:	Anglian Water
Date Completed:	07.02.24
Model Purpose:	
Model Assumptions:	
Flow Details:	https://mottmac.sharepoint.com/:x:/r/teams/pj-d2780/do/Develop/06%20-%20Technical%20Disciplines/12%20-%20Transport/03%20Technical%20Analysis/Traffic%20Flow%20Diagrams/Version%202%20-%20January%202024/Cambridge%20WWTP_Traffic%20Flow%20Diagrams.xlsx?d=w4f367f2dfb614195b49eedda3869d06c&csf=1&web=1&e=cAWS2S
Checked By:	TE
Additional detail:	
File name:	Milton Rd_Cowley Rd v2.lsg3x
Author:	ZB
Company:	Mott MacDonald
Address:	

Scenario 1: '2021 Base AM' (FG1: '2021 Base AM', Plan 1: 'Network Control Plan 1')

Network Layout Diagram

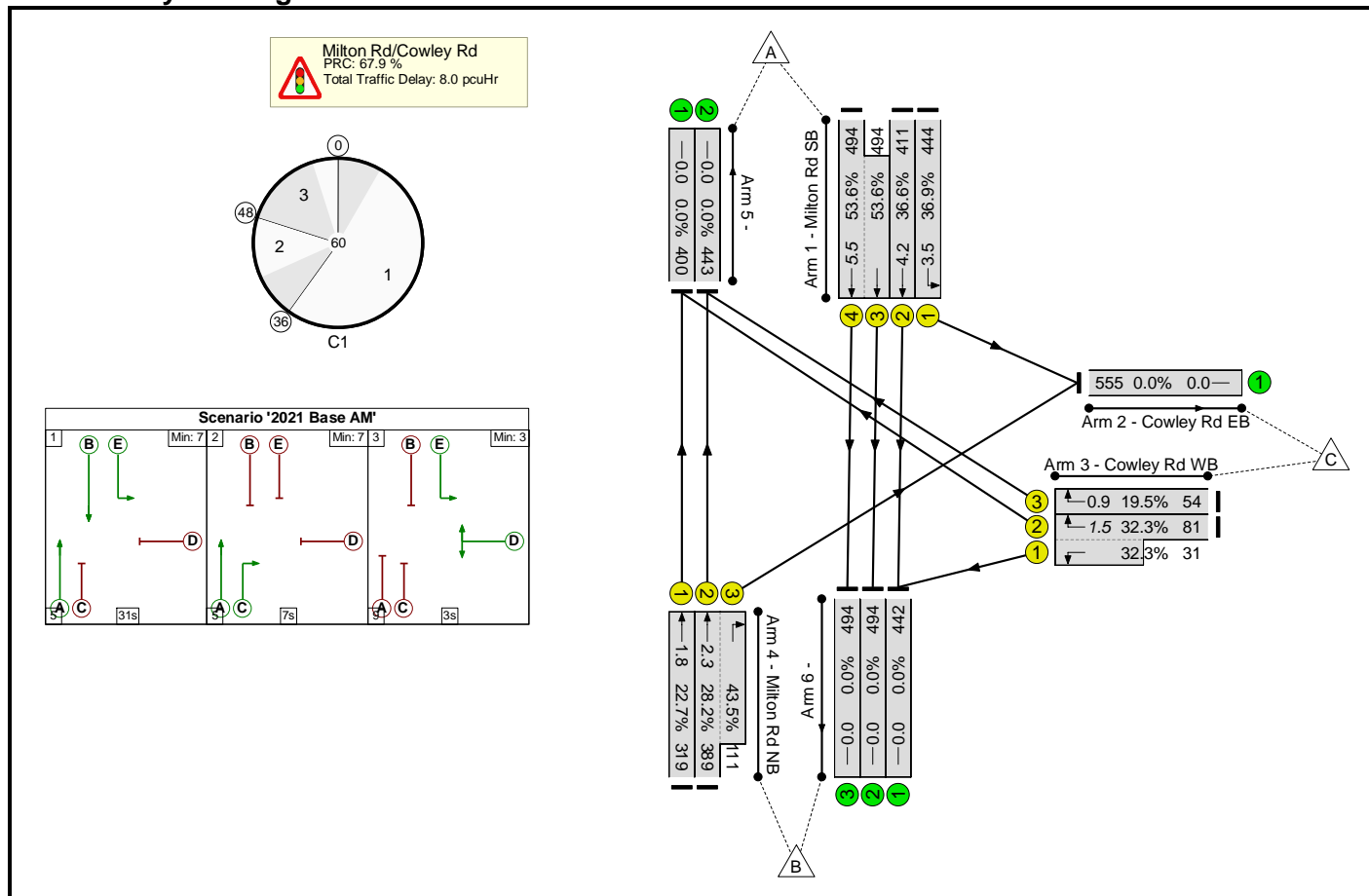

Basic Results Summary

Network Results

Item	Lane Description	Lane Type	Full Phase	Arrow Phase	Num Greens	Total Green (s)	Arrow Green (s)	Demand Flow (pcu)	Sat Flow (pcu/Hr)	Capacity (pcu)	Deg Sat (%)	Turners In Gaps (pcu)	Turners When Unopposed (pcu)	Turners In Intergreen (pcu)	Total Delay (pcuHr)	Av. Delay Per PCU (s/pcu)	Mean Max Queue (pcu)	
Network: AWS Cambridge WWTPRP EIA Stage 2	-	-	-		-	-	-	-	-	-	53.6%	0	0	0	8.0	-	-	
Milton Rd/Cowley Rd	-	-	-		-	-	-	-	-	-	53.6%	0	0	0	8.0	-	-	
1/1	Milton Rd SB Left	U	E		1	39	-	444	1807	1205	36.9%	-	-	-	0.8	6.8	3.5	
1/2	Milton Rd SB Ahead	U	B		1	31	-	411	2105	1123	36.6%	-	-	-	1.2	10.7	4.2	
1/4+1/3	Milton Rd SB Ahead	U	B		1	31	-	988	2105:2105	921+921	53.6 : 53.6%	-	-	-	2.9	10.6	5.5	
3/2+3/1	Cowley Rd WB Right Left	U	D		1	7	-	112	1879:1724	251+96	32.3 : 32.3%	-	-	-	1.0	31.1	1.5	
3/3	Cowley Rd WB Right	U	D		1	7	-	54	2080	277	19.5%	-	-	-	0.5	31.3	0.9	
4/1	Milton Rd NB Ahead	U	A		1	43	-	319	1915	1404	22.7%	-	-	-	0.4	4.2	1.8	
4/2+4/3	Milton Rd NB Right Ahead	U	A C		1	43:7	-	500	2055:1912	1379+255	28.2 : 43.5%	-	-	-	1.2	9.0	2.3	
C1					PRC for Signalled Lanes (%): 67.9			Total Delay for Signalled Lanes (pcuHr): 8.03			Cycle Time (s): 60							
					PRC Over All Lanes (%): 67.9			Total Delay Over All Lanes(pcuHr): 8.03										

Basic Results Summary

Scenario 2: '2021 Base PM' (FG2: '2021 Base PM', Plan 1: 'Network Control Plan 1')

Network Layout Diagram

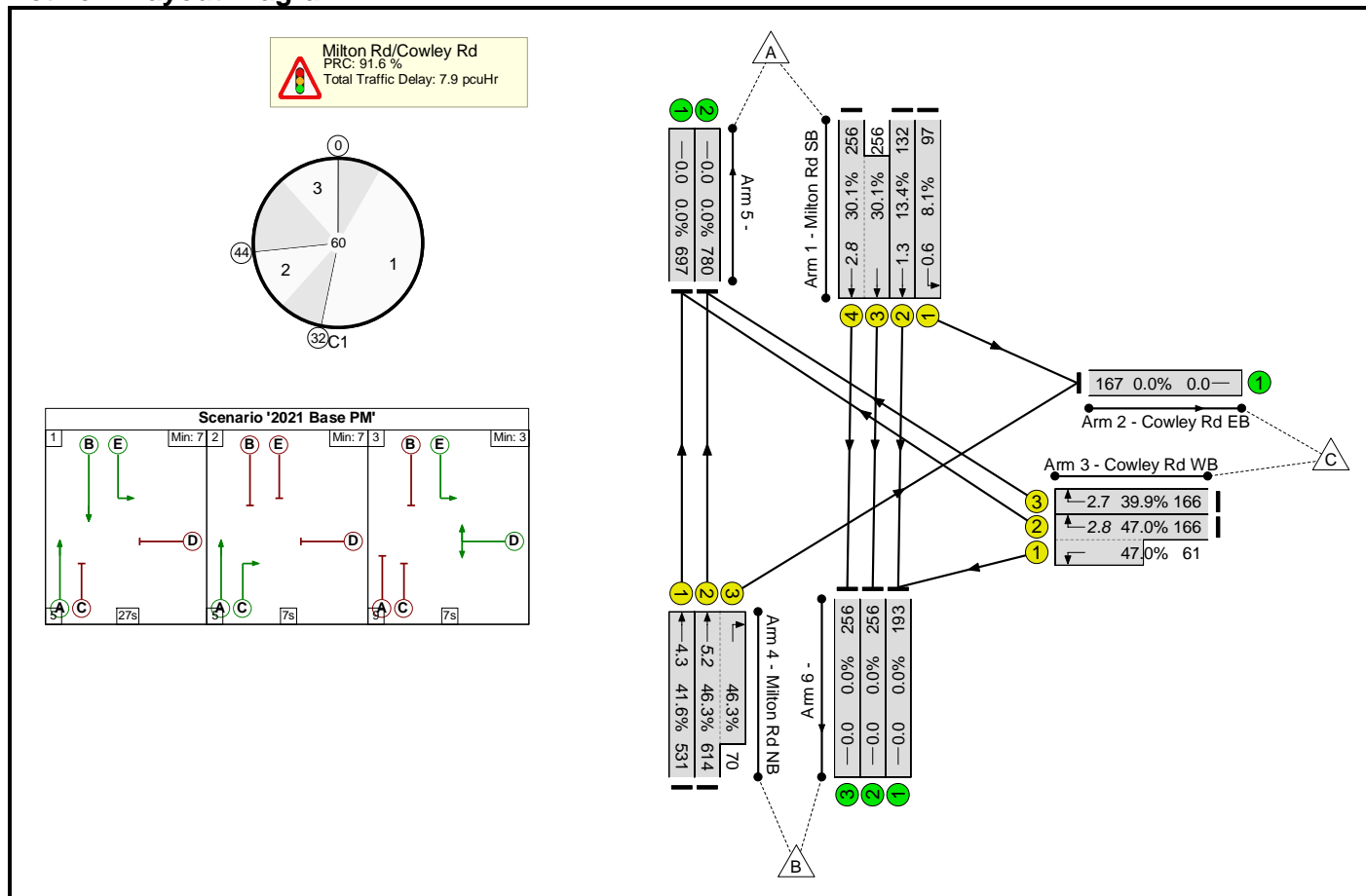

Basic Results Summary

Network Results

Item	Lane Description	Lane Type	Full Phase	Arrow Phase	Num Greens	Total Green (s)	Arrow Green (s)	Demand Flow (pcu)	Sat Flow (pcu/Hr)	Capacity (pcu)	Deg Sat (%)	Turners In Gaps (pcu)	Turners When Unopposed (pcu)	Turners In Intergreen (pcu)	Total Delay (pcuHr)	Av. Delay Per PCU (s/pcu)	Mean Max Queue (pcu)
Network: AWS Cambridge WWTPRP EIA Stage 2	-	-	-		-	-	-	-	-	-	47.0%	0	0	0	7.9	-	-
Milton Rd/Cowley Rd	-	-	-		-	-	-	-	-	-	47.0%	0	0	0	7.9	-	-
1/1	Milton Rd SB Left	U	E		1	39	-	97	1807	1205	8.1%	-	-	-	0.1	5.2	0.6
1/2	Milton Rd SB Ahead	U	B		1	27	-	132	2105	982	13.4%	-	-	-	0.4	11.2	1.3
1/4+1/3	Milton Rd SB Ahead	U	B		1	27	-	512	2105:2105	851+851	30.1 : 30.1%	-	-	-	1.6	11.2	2.8
3/2+3/1	Cowley Rd WB Right Left	U	D		1	11	-	227	1879:1724	353+130	47.0 : 47.0%	-	-	-	1.8	27.8	2.8
3/3	Cowley Rd WB Right	U	D		1	11	-	166	2080	416	39.9%	-	-	-	1.3	28.1	2.7
4/1	Milton Rd NB Ahead	U	A		1	39	-	531	1915	1277	41.6%	-	-	-	1.0	7.0	4.3
4/2+4/3	Milton Rd NB Right Ahead	U	A C		1	39:7	-	684	2055:1912	1326+151	46.3 : 46.3%	-	-	-	1.7	8.9	5.2
C1					PRC for Signalled Lanes (%):		91.6	Total Delay for Signalled Lanes (pcuHr):		7.93	Cycle Time (s):		60				
					PRC Over All Lanes (%):		91.6	Total Delay Over All Lanes(pcuHr):		7.93							

Basic Results Summary

Scenario 3: '2026 Base AM' (FG7: '2026 Base AM', Plan 1: 'Network Control Plan 1')

Network Layout Diagram

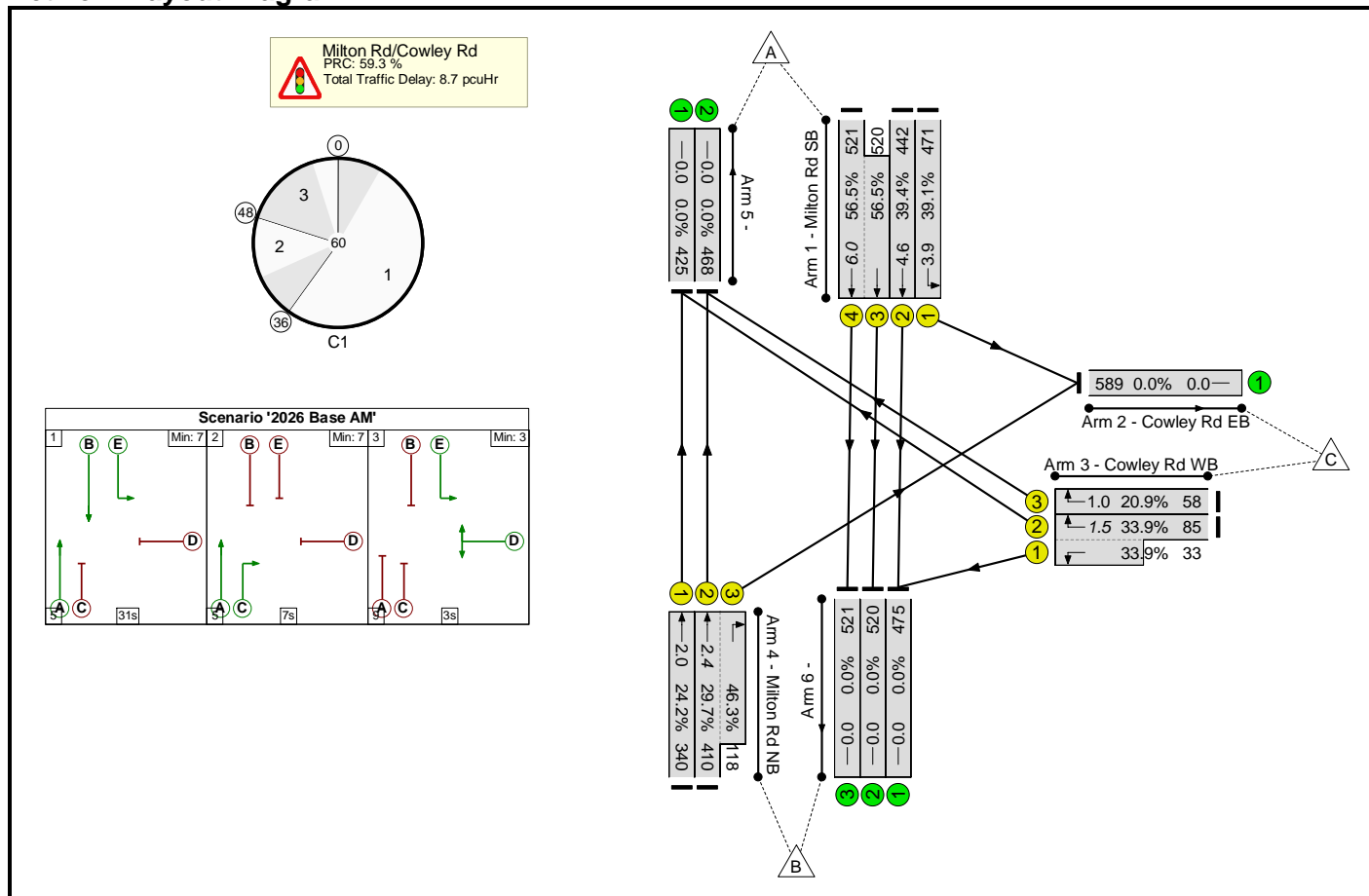

Basic Results Summary

Network Results

Item	Lane Description	Lane Type	Full Phase	Arrow Phase	Num Greens	Total Green (s)	Arrow Green (s)	Demand Flow (pcu)	Sat Flow (pcu/Hr)	Capacity (pcu)	Deg Sat (%)	Turners In Gaps (pcu)	Turners When Unopposed (pcu)	Turners In Intergreen (pcu)	Total Delay (pcuHr)	Av. Delay Per PCU (s/pcu)	Mean Max Queue (pcu)
Network: AWS Cambridge WWTPRP EIA Stage 2	-	-	-		-	-	-	-	-	-	56.5%	0	0	0	8.7	-	-
Milton Rd/Cowley Rd	-	-	-		-	-	-	-	-	-	56.5%	0	0	0	8.7	-	-
1/1	Milton Rd SB Left	U	E		1	39	-	471	1807	1205	39.1%	-	-	-	0.9	7.0	3.9
1/2	Milton Rd SB Ahead	U	B		1	31	-	442	2105	1123	39.4%	-	-	-	1.3	10.9	4.6
1/4+1/3	Milton Rd SB Ahead	U	B		1	31	-	1041	2105:2105	922+920	56.5 : 56.5%	-	-	-	3.2	10.9	6.0
3/2+3/1	Cowley Rd WB Right Left	U	D		1	7	-	118	1879:1724	251+97	33.9 : 33.9%	-	-	-	1.0	31.3	1.5
3/3	Cowley Rd WB Right	U	D		1	7	-	58	2080	277	20.9%	-	-	-	0.5	31.4	1.0
4/1	Milton Rd NB Ahead	U	A		1	43	-	340	1915	1404	24.2%	-	-	-	0.4	4.3	2.0
4/2+4/3	Milton Rd NB Right Ahead	U	A C		1	43:7	-	528	2055:1912	1379+255	29.7 : 46.3%	-	-	-	1.3	9.1	2.4
		C1			PRC for Signalled Lanes (%):		59.3	Total Delay for Signalled Lanes (pcuHr):		8.68		Cycle Time (s):		60			
				PRC Over All Lanes (%):		59.3		Total Delay Over All Lanes(pcuHr):		8.68							

Basic Results Summary

Scenario 4: '2026 Base PM' (FG8: '2026 Base PM', Plan 1: 'Network Control Plan 1')

Network Layout Diagram

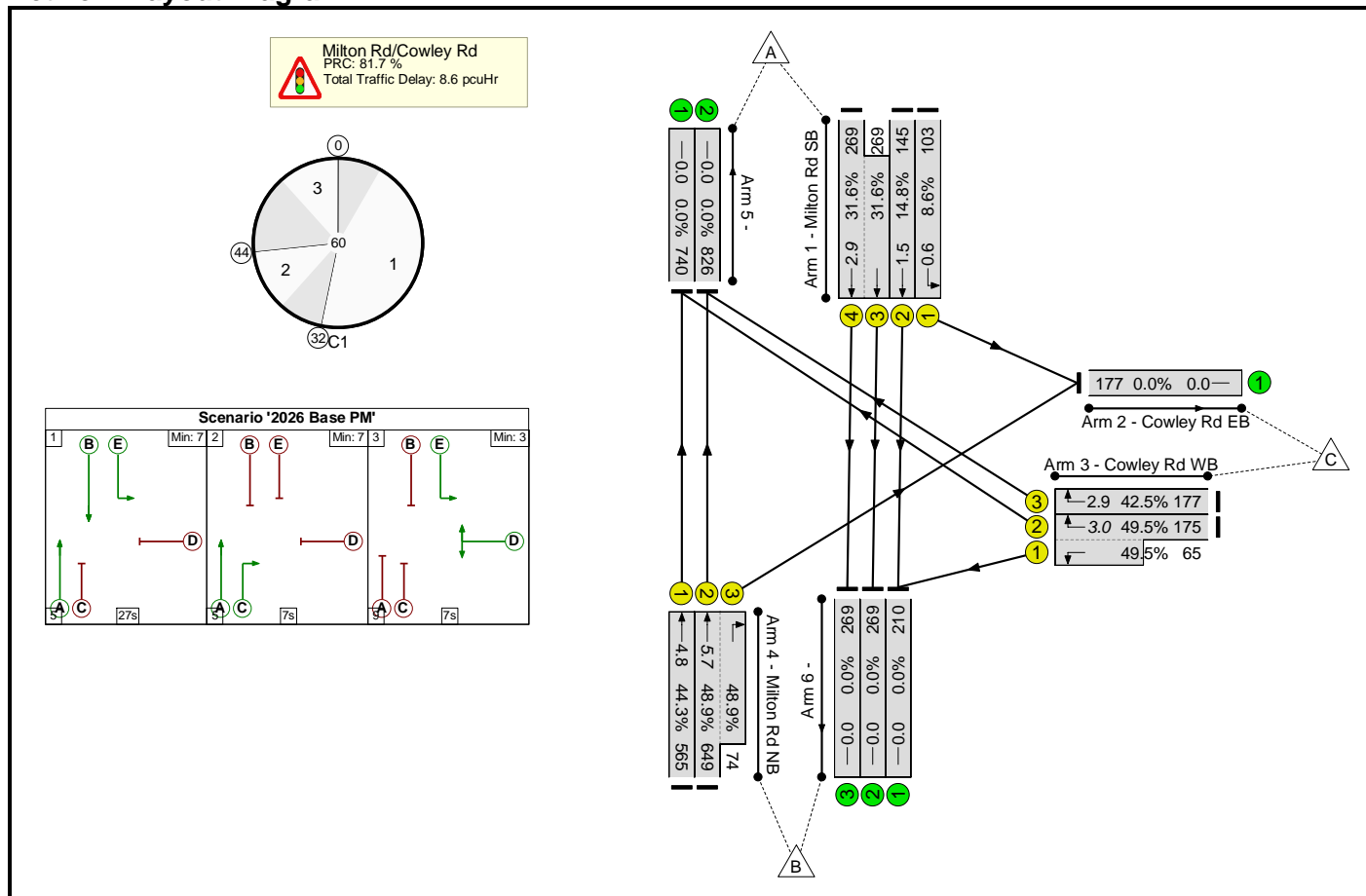

Basic Results Summary

Network Results

Item	Lane Description	Lane Type	Full Phase	Arrow Phase	Num Greens	Total Green (s)	Arrow Green (s)	Demand Flow (pcu)	Sat Flow (pcu/Hr)	Capacity (pcu)	Deg Sat (%)	Turners In Gaps (pcu)	Turners When Unopposed (pcu)	Turners In Intergreen (pcu)	Total Delay (pcuHr)	Av. Delay Per PCU (s/pcu)	Mean Max Queue (pcu)	
Network: AWS Cambridge WWTPRP EIA Stage 2	-	-	-		-	-	-	-	-	-	49.5%	0	0	0	8.6	-	-	
Milton Rd/Cowley Rd	-	-	-		-	-	-	-	-	-	49.5%	0	0	0	8.6	-	-	
1/1	Milton Rd SB Left	U	E		1	39	-	103	1807	1205	8.6%	-	-	-	0.1	5.2	0.6	
1/2	Milton Rd SB Ahead	U	B		1	27	-	145	2105	982	14.8%	-	-	-	0.5	11.3	1.5	
1/4+1/3	Milton Rd SB Ahead	U	B		1	27	-	538	2105:2105	851+851	31.6 : 31.6%	-	-	-	1.7	11.3	2.9	
3/2+3/1	Cowley Rd WB Right Left	U	D		1	11	-	240	1879:1724	353+131	49.5 : 49.5%	-	-	-	1.9	28.2	3.0	
3/3	Cowley Rd WB Right	U	D		1	11	-	177	2080	416	42.5%	-	-	-	1.4	28.5	2.9	
4/1	Milton Rd NB Ahead	U	A		1	39	-	565	1915	1277	44.3%	-	-	-	1.1	7.3	4.8	
4/2+4/3	Milton Rd NB Right Ahead	U	A C		1	39:7	-	723	2055:1912	1326+151	48.9 : 48.9%	-	-	-	1.8	9.2	5.7	
C1					PRC for Signalled Lanes (%): 81.7			Total Delay for Signalled Lanes (pcuHr): 8.56			Cycle Time (s): 60							
					PRC Over All Lanes (%): 81.7			Total Delay Over All Lanes(pcuHr): 8.56										

Basic Results Summary

Scenario 5: '2028 Base AM' (FG3: '2028 Base AM', Plan 1: 'Network Control Plan 1')

Network Layout Diagram

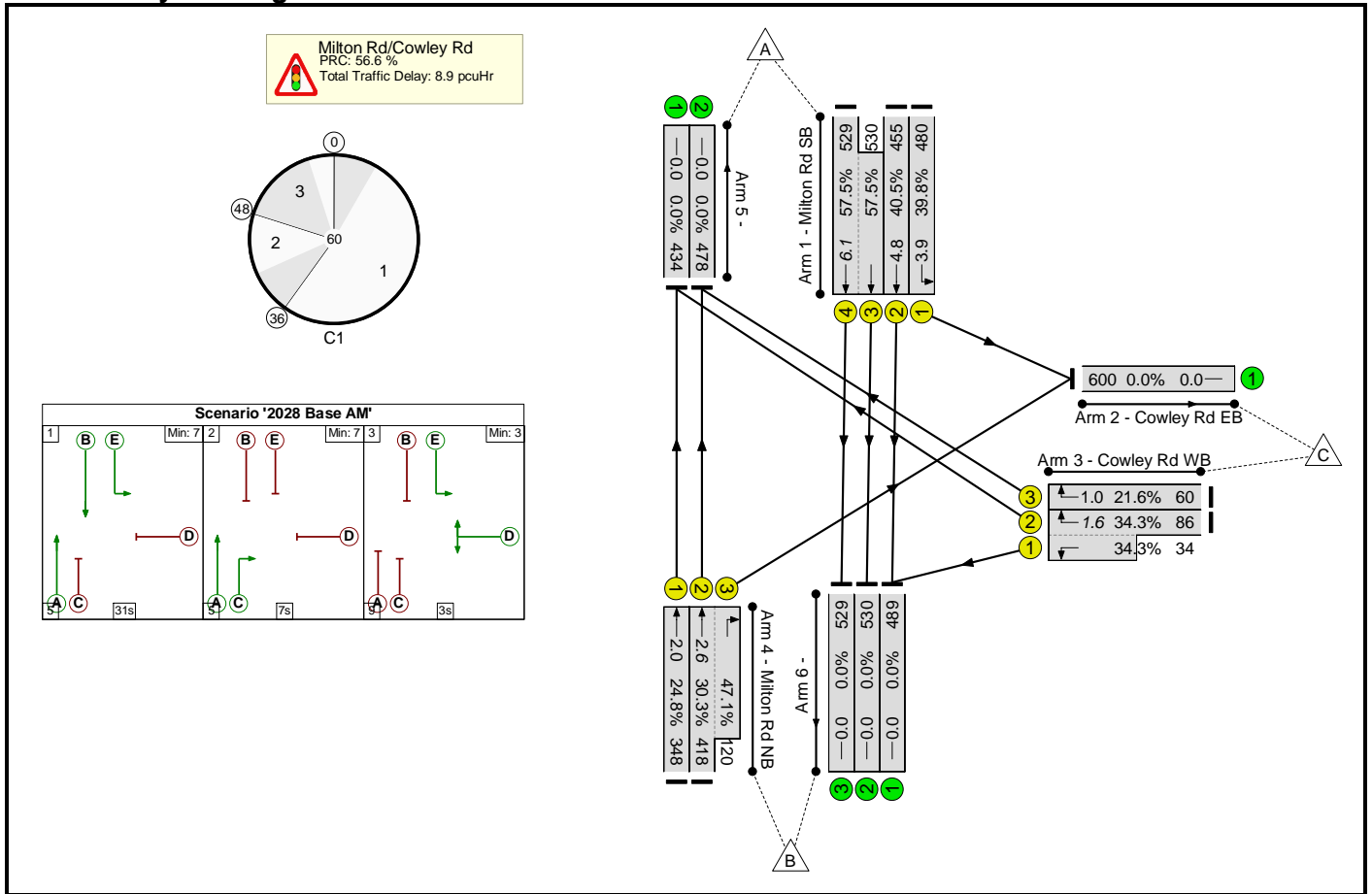

Basic Results Summary

Network Results

Item	Lane Description	Lane Type	Full Phase	Arrow Phase	Num Greens	Total Green (s)	Arrow Green (s)	Demand Flow (pcu)	Sat Flow (pcu/Hr)	Capacity (pcu)	Deg Sat (%)	Turners In Gaps (pcu)	Turners When Unopposed (pcu)	Turners In Intergreen (pcu)	Total Delay (pcuHr)	Av. Delay Per PCU (s/pcu)	Mean Max Queue (pcu)	
Network: AWS Cambridge WWTPRP EIA Stage 2	-	-	-		-	-	-	-	-	-	57.5%	0	0	0	8.9	-	-	
Milton Rd/Cowley Rd	-	-	-		-	-	-	-	-	-	57.5%	0	0	0	8.9	-	-	
1/1	Milton Rd SB Left	U	E		1	39	-	480	1807	1205	39.8%	-	-	-	0.9	7.0	3.9	
1/2	Milton Rd SB Ahead	U	B		1	31	-	455	2105	1123	40.5%	-	-	-	1.4	11.0	4.8	
1/4+1/3	Milton Rd SB Ahead	U	B		1	31	-	1059	2105:2105	920+922	57.5 : 57.5%	-	-	-	3.2	11.0	6.1	
3/2+3/1	Cowley Rd WB Right Left	U	D		1	7	-	120	1879:1724	251+99	34.3 : 34.3%	-	-	-	1.0	31.3	1.6	
3/3	Cowley Rd WB Right	U	D		1	7	-	60	2080	277	21.6%	-	-	-	0.5	31.5	1.0	
4/1	Milton Rd NB Ahead	U	A		1	43	-	348	1915	1404	24.8%	-	-	-	0.4	4.3	2.0	
4/2+4/3	Milton Rd NB Right Ahead	U	A C		1	43:7	-	538	2055:1912	1379+255	30.3 : 47.1%	-	-	-	1.4	9.1	2.6	
C1					PRC for Signalled Lanes (%):		56.6	Total Delay for Signalled Lanes (pcuHr):				8.92	Cycle Time (s):		60			
					PRC Over All Lanes (%):		56.6	Total Delay Over All Lanes (pcuHr):				8.92						

Basic Results Summary

Scenario 6: '2028 Base PM' (FG4: '2028 Base PM', Plan 1: 'Network Control Plan 1')

Network Layout Diagram

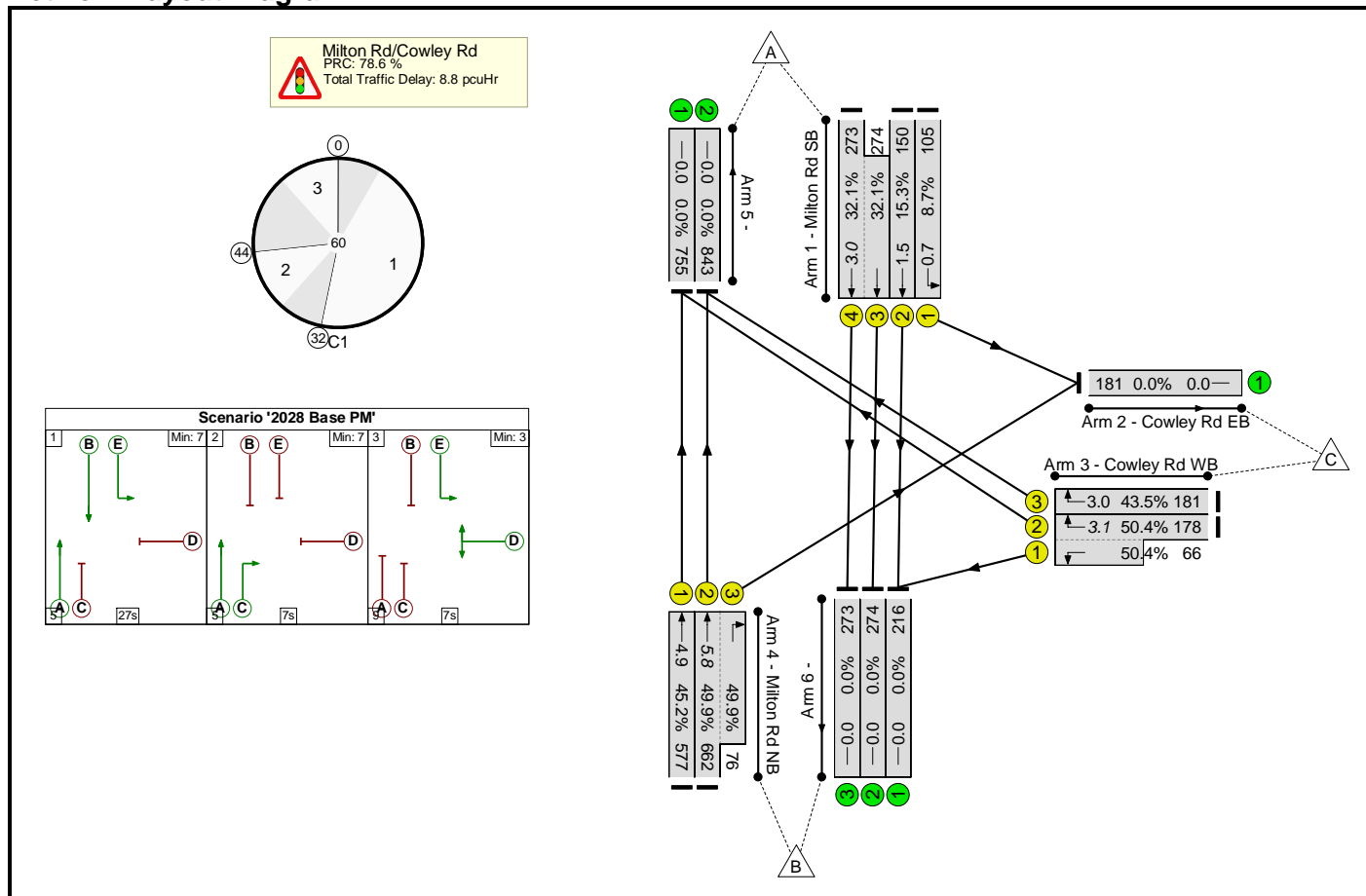

Basic Results Summary

Network Results

Item	Lane Description	Lane Type	Full Phase	Arrow Phase	Num Greens	Total Green (s)	Arrow Green (s)	Demand Flow (pcu)	Sat Flow (pcu/Hr)	Capacity (pcu)	Deg Sat (%)	Turners In Gaps (pcu)	Turners When Unopposed (pcu)	Turners In Intergreen (pcu)	Total Delay (pcuHr)	Av. Delay Per PCU (s/pcu)	Mean Max Queue (pcu)
Network: AWS Cambridge WWTPRP EIA Stage 2	-	-	-		-	-	-	-	-	-	50.4%	0	0	0	8.8	-	-
Milton Rd/Cowley Rd	-	-	-		-	-	-	-	-	-	50.4%	0	0	0	8.8	-	-
1/1	Milton Rd SB Left	U	E		1	39	-	105	1807	1205	8.7%	-	-	-	0.2	5.2	0.7
1/2	Milton Rd SB Ahead	U	B		1	27	-	150	2105	982	15.3%	-	-	-	0.5	11.4	1.5
1/4+1/3	Milton Rd SB Ahead	U	B		1	27	-	547	2105:2105	849+852	32.1 : 32.1%	-	-	-	1.7	11.4	3.0
3/2+3/1	Cowley Rd WB Right Left	U	D		1	11	-	244	1879:1724	353+131	50.4 : 50.4%	-	-	-	1.9	28.3	3.1
3/3	Cowley Rd WB Right	U	D		1	11	-	181	2080	416	43.5%	-	-	-	1.4	28.7	3.0
4/1	Milton Rd NB Ahead	U	A		1	39	-	577	1915	1277	45.2%	-	-	-	1.2	7.3	4.9
4/2+4/3	Milton Rd NB Right Ahead	U	A C		1	39:7	-	738	2055:1912	1326+152	49.9 : 49.9%	-	-	-	1.9	9.3	5.8
C1					PRC for Signalled Lanes (%):		78.6	Total Delay for Signalled Lanes (pcuHr):			8.79	Cycle Time (s):		60			
					PRC Over All Lanes (%):		78.6	Total Delay Over All Lanes(pcuHr):			8.79						

Basic Results Summary

Scenario 11: '2026 + Construction AM' (FG17: '2026 + Construction AM', Plan 1: 'Network Control Plan 1')

Network Layout Diagram

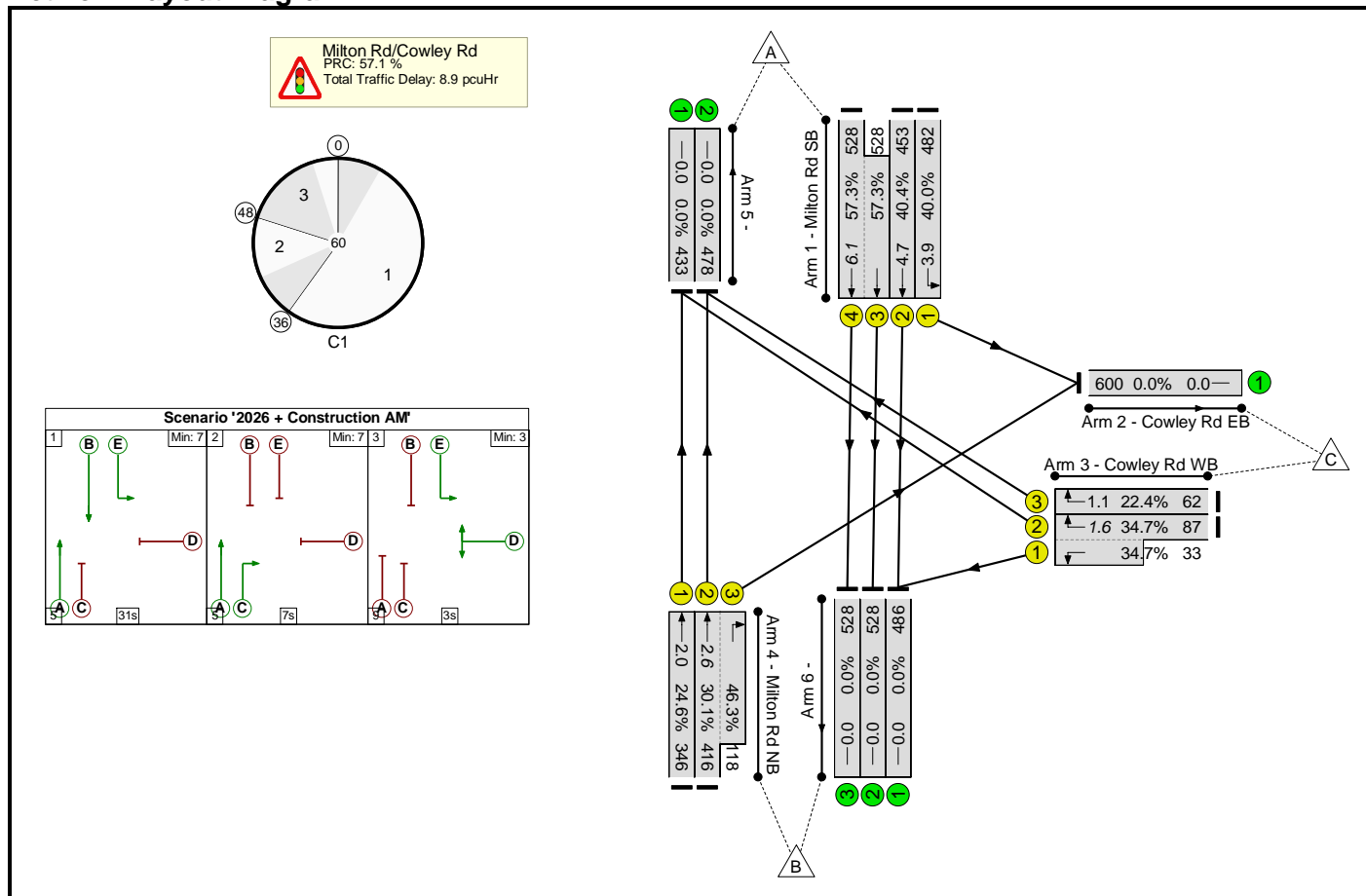

Basic Results Summary

Network Results

Item	Lane Description	Lane Type	Full Phase	Arrow Phase	Num Greens	Total Green (s)	Arrow Green (s)	Demand Flow (pcu)	Sat Flow (pcu/Hr)	Capacity (pcu)	Deg Sat (%)	Turners In Gaps (pcu)	Turners When Unopposed (pcu)	Turners In Intergreen (pcu)	Total Delay (pcuHr)	Av. Delay Per PCU (s/pcu)	Mean Max Queue (pcu)
Network: AWS Cambridge WWTPRP EIA Stage 2	-	-	-		-	-	-	-	-	-	57.3%	0	0	0	8.9	-	-
Milton Rd/Cowley Rd	-	-	-		-	-	-	-	-	-	57.3%	0	0	0	8.9	-	-
1/1	Milton Rd SB Left	U	E		1	39	-	482	1807	1205	40.0%	-	-	-	0.9	7.0	3.9
1/2	Milton Rd SB Ahead	U	B		1	31	-	453	2105	1123	40.4%	-	-	-	1.4	11.0	4.7
1/4+1/3	Milton Rd SB Ahead	U	B		1	31	-	1056	2105:2105	921+921	57.3 : 57.3%	-	-	-	3.2	11.0	6.1
3/2+3/1	Cowley Rd WB Right Left	U	D		1	7	-	120	1879:1724	251+95	34.7 : 34.7%	-	-	-	1.0	31.4	1.6
3/3	Cowley Rd WB Right	U	D		1	7	-	62	2080	277	22.4%	-	-	-	0.5	31.6	1.1
4/1	Milton Rd NB Ahead	U	A		1	43	-	346	1915	1404	24.6%	-	-	-	0.4	4.3	2.0
4/2+4/3	Milton Rd NB Right Ahead	U	A C		1	43:7	-	534	2055:1912	1380+255	30.1 : 46.3%	-	-	-	1.3	9.0	2.6
		C1			PRC for Signalled Lanes (%):		57.1	Total Delay for Signalled Lanes (pcuHr):		8.91	Cycle Time (s):		60				
					PRC Over All Lanes (%):		57.1	Total Delay Over All Lanes(pcuHr):		8.91							

Basic Results Summary

Scenario 12: '2026 + Construction PM' (FG18: '2026 + Construction PM', Plan 1: 'Network Control Plan 1')

Network Layout Diagram

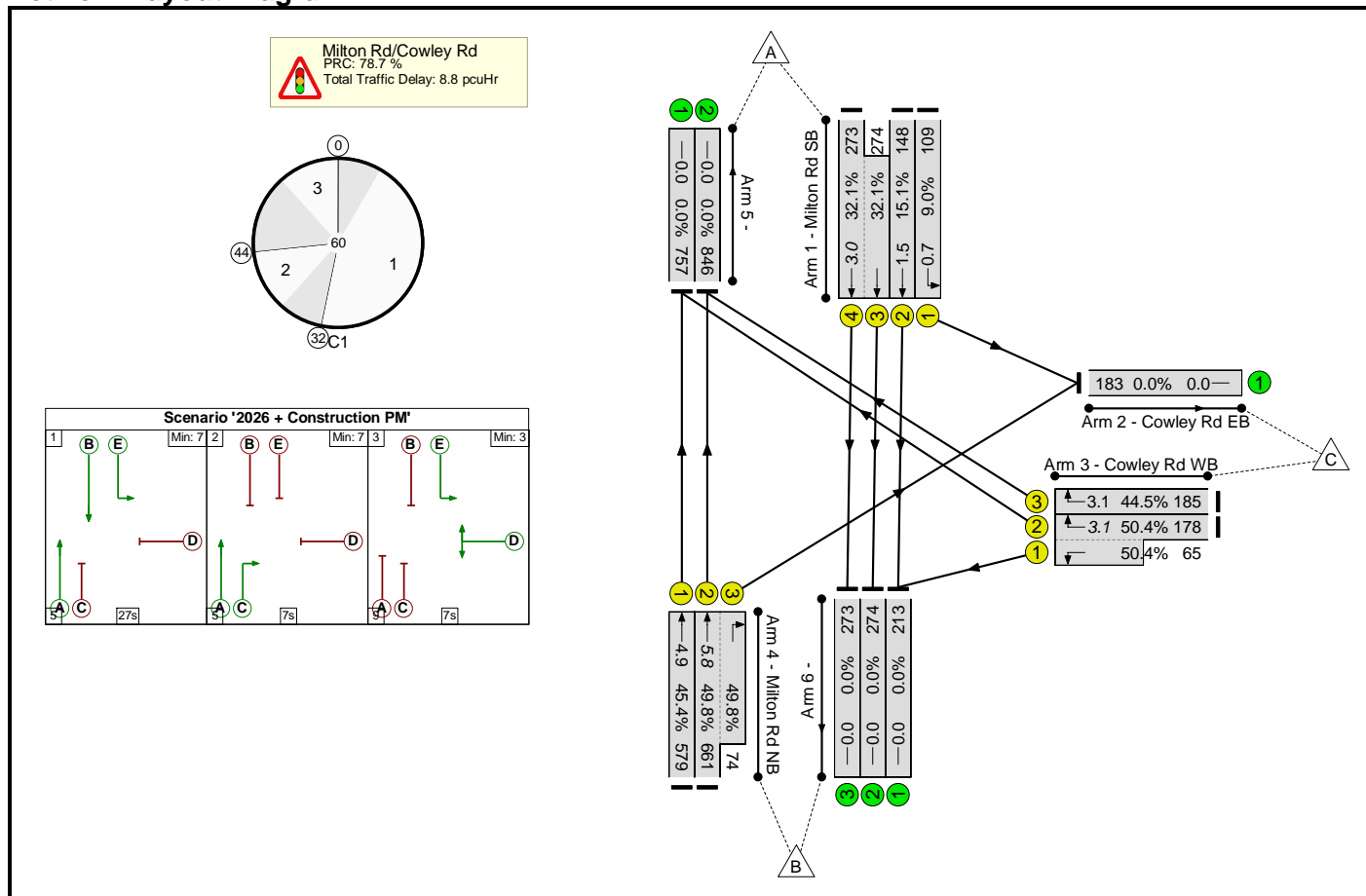

Basic Results Summary

Network Results

Item	Lane Description	Lane Type	Full Phase	Arrow Phase	Num Greens	Total Green (s)	Arrow Green (s)	Demand Flow (pcu)	Sat Flow (pcu/Hr)	Capacity (pcu)	Deg Sat (%)	Turners In Gaps (pcu)	Turners When Unopposed (pcu)	Turners In Intergreen (pcu)	Total Delay (pcuHr)	Av. Delay Per PCU (s/pcu)	Mean Max Queue (pcu)
Network: AWS Cambridge WWTPRP EIA Stage 2	-	-	-		-	-	-	-	-	-	50.4%	0	0	0	8.8	-	-
Milton Rd/Cowley Rd	-	-	-		-	-	-	-	-	-	50.4%	0	0	0	8.8	-	-
1/1	Milton Rd SB Left	U	E		1	39	-	109	1807	1205	9.0%	-	-	-	0.2	5.2	0.7
1/2	Milton Rd SB Ahead	U	B		1	27	-	148	2105	982	15.1%	-	-	-	0.5	11.4	1.5
1/4+1/3	Milton Rd SB Ahead	U	B		1	27	-	547	2105:2105	849+852	32.1 : 32.1%	-	-	-	1.7	11.4	3.0
3/2+3/1	Cowley Rd WB Right Left	U	D		1	11	-	243	1879:1724	353+129	50.4 : 50.4%	-	-	-	1.9	28.4	3.1
3/3	Cowley Rd WB Right	U	D		1	11	-	185	2080	416	44.5%	-	-	-	1.5	28.9	3.1
4/1	Milton Rd NB Ahead	U	A		1	39	-	579	1915	1277	45.4%	-	-	-	1.2	7.4	4.9
4/2+4/3	Milton Rd NB Right Ahead	U	A C		1	39:7	-	735	2055:1912	1327+149	49.8 : 49.8%	-	-	-	1.9	9.2	5.8
C1					PRC for Signalled Lanes (%):		78.7	Total Delay for Signalled Lanes (pcuHr):		8.82	Cycle Time (s):		60				
					PRC Over All Lanes (%):		78.7	Total Delay Over All Lanes(pcuHr):		8.82							

Basic Results Summary

Scenario 13: '2028 Decommissioning AM' (FG15: '2028 Decommissioning AM', Plan 1: 'Network Control Plan 1')

Network Layout Diagram

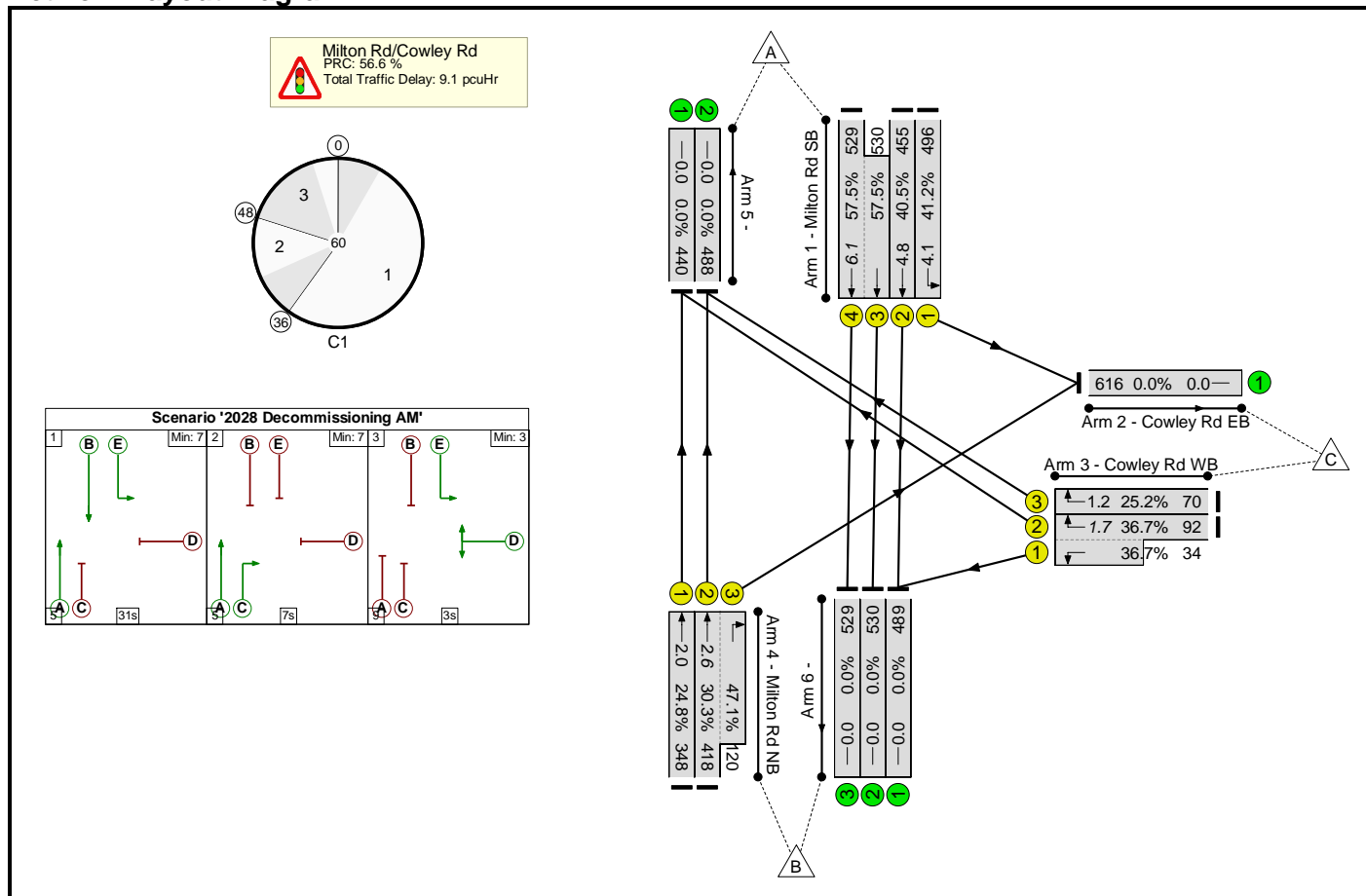

Basic Results Summary

Network Results

Item	Lane Description	Lane Type	Full Phase	Arrow Phase	Num Greens	Total Green (s)	Arrow Green (s)	Demand Flow (pcu)	Sat Flow (pcu/Hr)	Capacity (pcu)	Deg Sat (%)	Turners In Gaps (pcu)	Turners When Unopposed (pcu)	Turners In Intergreen (pcu)	Total Delay (pcuHr)	Av. Delay Per PCU (s/pcu)	Mean Max Queue (pcu)
Network: AWS Cambridge WWTPRP EIA Stage 2	-	-	-		-	-	-	-	-	-	57.5%	0	0	0	9.1	-	-
Milton Rd/Cowley Rd	-	-	-		-	-	-	-	-	-	57.5%	0	0	0	9.1	-	-
1/1	Milton Rd SB Left	U	E		1	39	-	496	1807	1205	41.2%	-	-	-	1.0	7.1	4.1
1/2	Milton Rd SB Ahead	U	B		1	31	-	455	2105	1123	40.5%	-	-	-	1.4	11.0	4.8
1/4+1/3	Milton Rd SB Ahead	U	B		1	31	-	1059	2105:2105	920+922	57.5 : 57.5%	-	-	-	3.2	11.0	6.1
3/2+3/1	Cowley Rd WB Right Left	U	D		1	7	-	126	1879:1724	251+93	36.7 : 36.7%	-	-	-	1.1	31.8	1.7
3/3	Cowley Rd WB Right	U	D		1	7	-	70	2080	277	25.2%	-	-	-	0.6	32.0	1.2
4/1	Milton Rd NB Ahead	U	A		1	43	-	348	1915	1404	24.8%	-	-	-	0.4	4.3	2.0
4/2+4/3	Milton Rd NB Right Ahead	U	A C		1	43:7	-	538	2055:1912	1379+255	30.3 : 47.1%	-	-	-	1.4	9.1	2.6
C1					PRC for Signalled Lanes (%):		56.6	Total Delay for Signalled Lanes (pcuHr):			9.13	Cycle Time (s):		60			
					PRC Over All Lanes (%):		56.6	Total Delay Over All Lanes(pcuHr):			9.13						

Basic Results Summary

Scenario 14: '2028 Decommissioning PM' (FG16: '2028 Decommissioning PM', Plan 1: 'Network Control Plan 1')

Network Layout Diagram

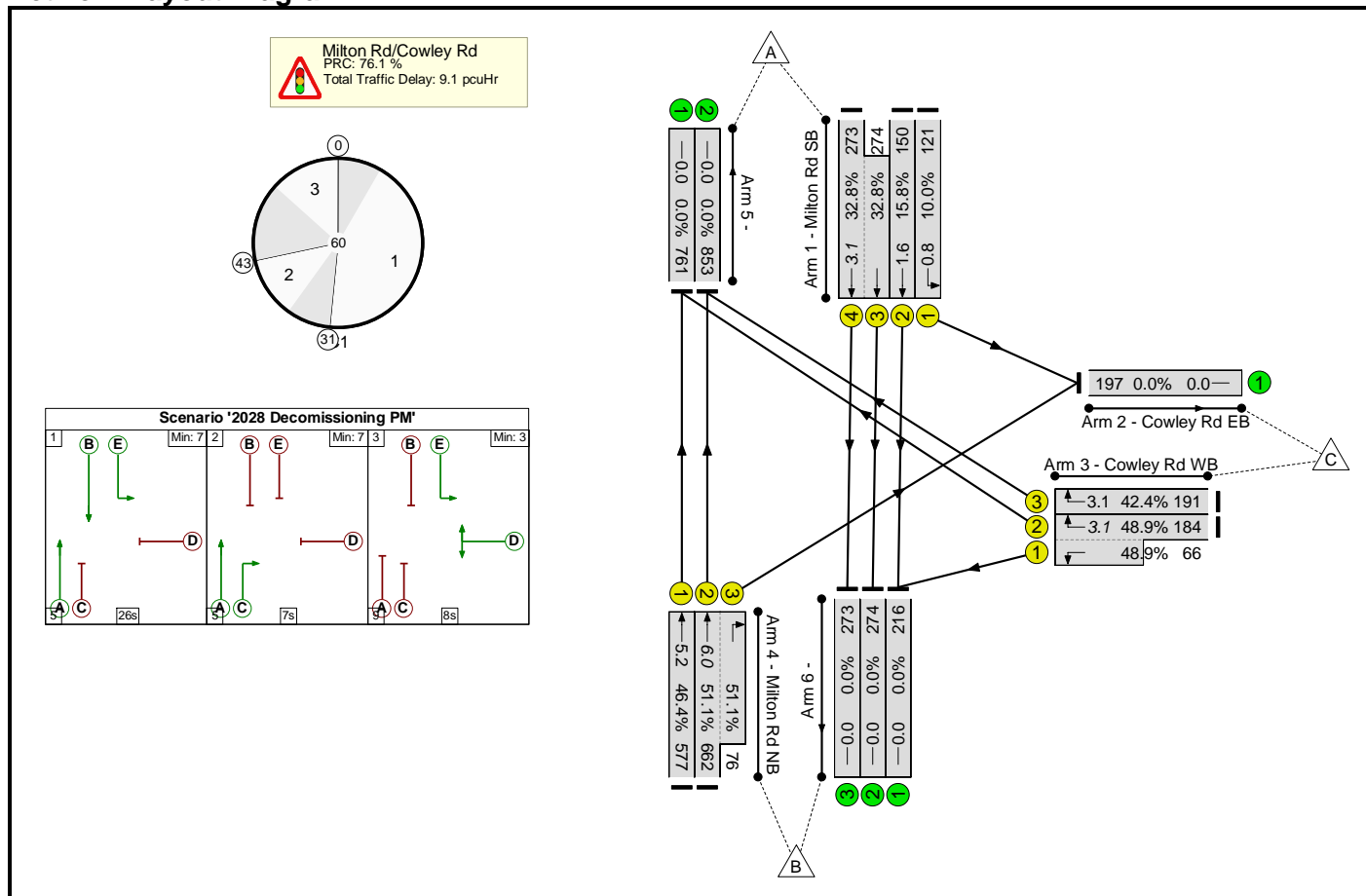

Basic Results Summary

Network Results

Item	Lane Description	Lane Type	Full Phase	Arrow Phase	Num Greens	Total Green (s)	Arrow Green (s)	Demand Flow (pcu)	Sat Flow (pcu/Hr)	Capacity (pcu)	Deg Sat (%)	Turners In Gaps (pcu)	Turners When Unopposed (pcu)	Turners In Intergreen (pcu)	Total Delay (pcuHr)	Av. Delay Per PCU (s/pcu)	Mean Max Queue (pcu)					
Network: AWS Cambridge WWTPRP EIA Stage 2	-	-	-		-	-	-	-	-	-	51.1%	0	0	0	9.1	-	-					
Milton Rd/Cowley Rd	-	-	-		-	-	-	-	-	-	51.1%	0	0	0	9.1	-	-					
1/1	Milton Rd SB Left	U	E		1	39	-	121	1807	1205	10.0%	-	-	-	0.2	5.3	0.8					
1/2	Milton Rd SB Ahead	U	B		1	26	-	150	2105	947	15.8%	-	-	-	0.5	12.1	1.6					
1/4+1/3	Milton Rd SB Ahead	U	B		1	26	-	547	2105:2105	832+835	32.8 : 32.8%	-	-	-	1.8	12.0	3.1					
3/2+3/1	Cowley Rd WB Right Left	U	D		1	12	-	250	1879:1724	376+135	48.9 : 48.9%	-	-	-	1.9	27.0	3.1					
3/3	Cowley Rd WB Right	U	D		1	12	-	191	2080	451	42.4%	-	-	-	1.4	27.2	3.1					
4/1	Milton Rd NB Ahead	U	A		1	38	-	577	1915	1245	46.4%	-	-	-	1.3	8.0	5.2					
4/2+4/3	Milton Rd NB Right Ahead	U	A C		1	38:7	-	738	2055:1912	1295+149	51.1 : 51.1%	-	-	-	2.0	9.8	6.0					
		C1	PRC for Signalled Lanes (%):		76.1		PRC Over All Lanes (%):		76.1		Total Delay for Signalled Lanes (pcuHr):		9.11		Total Delay Over All Lanes(pcuHr):		9.11		Cycle Time (s):		60	

7 Milton Road / Green End Road / Kings Hedges (LinSig)

- 2021 Baseline AM
- 2021 Baseline PM
- Construction Year 3 (2026) – Future Baseline AM
- Construction Year 3 (2026) – Future Baseline PM
- Construction Year 3 (2026) – Construction Peak AM
- Construction Year 3 (2026) – Construction Peak PM

Basic Results Summary
Basic Results Summary

User and Project Details

Project:	100102041 – AWS Cambridge WWTPRP
Title:	Milton Road/King Hedges Road/Green End Road
Location:	
Client:	Anglian Water
Date Completed:	22.03.24
Flow Details:	https://mottmac.sharepoint.com/teams/pj-d2780/do/Develop/06%20-%20Technical%20Disciplines/12%20-%20Transport/13%20-%20Documents%20for%20Independent%20Review/1%20Traffic%20flow/Flow%20Diagrams/WIP/Cambridge%20WWTP_Traffic%20Flow%20Diagrams_v3.xlsx?web=1
Checked By:	GW
Checked By Date:	22.03.24
Additional detail:	
File name:	Milton Rd_Kings Hedges_Green End_adjusted_v2.lsg3x
Author:	CD
Company:	Mott MacDonald
Address:	

Scenario 1: '2021 Base AM' (FG1: '2021 Base AM', Plan 1: 'Network Control Plan 1 AM')
Network Layout Diagram

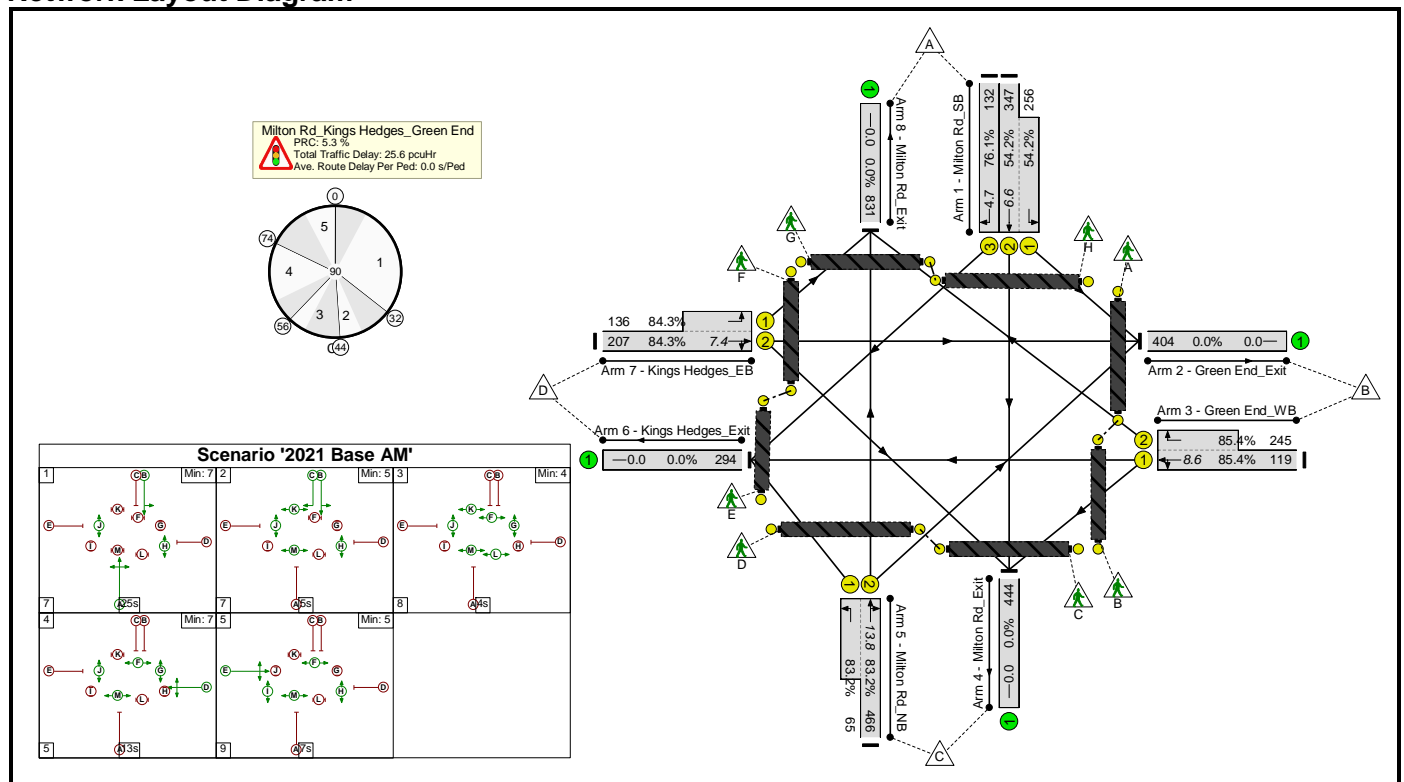

Basic Results Summary

Network Results

Item	Lane Description	Lane Type	Full Phase	Arrow Phase	Num Greens	Total Green (s)	Arrow Green (s)	Demand Flow (pcu)	Sat Flow (pcu/Hr)	Capacity (pcu)	Deg Sat (%)	Turners In Gaps (pcu)	Turners When Unopposed (pcu)	Turners In Intergreen (pcu)	Total Delay (pcuHr)	Av. Delay Per PCU (s/pcu)	Mean Max Queue (pcu)	Item
Network: Milton Road/King Hedges Road/Green End Road	-	-	-		-	-	-	-	-	-	85.4%	0	0	0	25.6	-	-	Network: Milton Road/King Hedges Road/Green End Road
Milton Rd_Kings Hedges_Green End	-	-	-		-	-	-	-	-	-	85.4%	0	0	0	25.6	-	-	Milton Rd_Kings Hedges_Green End
1/2+1/1	Milton Rd_SB Left Ahead	U	B		1	37	-	603	2055:1826	640+472	54.2 : 54.2%	-	-	-	3.6	21.3	6.6	1/2+1/1
1/3	Milton Rd_SB Right	U	C		1	7	-	132	1951	173	76.1%	-	-	-	3.0	80.6	4.7	1/3
3/1+3/2	Green End_WB Left Ahead Right	U	D		1	13	-	364	1913:1971	139+287	85.4 : 85.4%	-	-	-	6.3	62.5	8.6	3/1+3/2
5/2+5/1	Milton Rd_NB Right Left Ahead	U	A		1	25	-	531	2075:1798	560+78	83.2 : 83.2%	-	-	-	6.7	45.3	13.8	5/2+5/1
7/2+7/1	Kings Hedges_EB Ahead Right Left	U	E		1	11	-	343	2049:1811	246+161	84.3 : 84.3%	-	-	-	6.0	63.3	7.4	7/2+7/1
Ped Link: P1	Unnamed Ped Link	-	G		1	22	-	0	-	17600	0.0%	-	-	-	0.0	0.0	0.0	Ped Link: P1
Ped Link: P2	Unnamed Ped Link	-	H		1	55	-	0	-	44000	0.0%	-	-	-	0.0	0.0	0.0	Ped Link: P2
Ped Link: P3	Unnamed Ped Link	-	L		1	5	-	0	-	4000	0.0%	-	-	-	0.0	0.0	0.0	Ped Link: P3
Ped Link: P4	Unnamed Ped Link	-	M		1	53	-	0	-	42400	0.0%	-	-	-	0.0	0.0	0.0	Ped Link: P4
Ped Link: P5	Unnamed Ped Link	-	J		1	68	-	0	-	54400	0.0%	-	-	-	0.0	0.0	0.0	Ped Link: P5

Basic Results Summary

Ped Link: P6	Unnamed Ped Link	-	I		1	7	-	0	-	5600	0.0%	-	-	-	0.0	0.0	0.0	Ped Link: P6
Ped Link: P7	Unnamed Ped Link	-	K		1	17	-	0	-	13600	0.0%	-	-	-	0.0	0.0	0.0	Ped Link: P7
Ped Link: P8	Unnamed Ped Link	-	F		1	41	-	0	-	32800	0.0%	-	-	-	0.0	0.0	0.0	Ped Link: P8
		C1			PRC for Signalled Lanes (%):		5.3		Total Delay for Signalled Lanes (pcuHr):		25.57		Cycle Time (s):		90			
					PRC Over All Lanes (%):		5.3		Total Delay Over All Lanes(pcuHr):		25.57							

Basic Results Summary

Scenario 2: '2021 Base PM' (FG2: '2021 Base PM', Plan 1: 'Network Control Plan 1 AM')

Network Layout Diagram

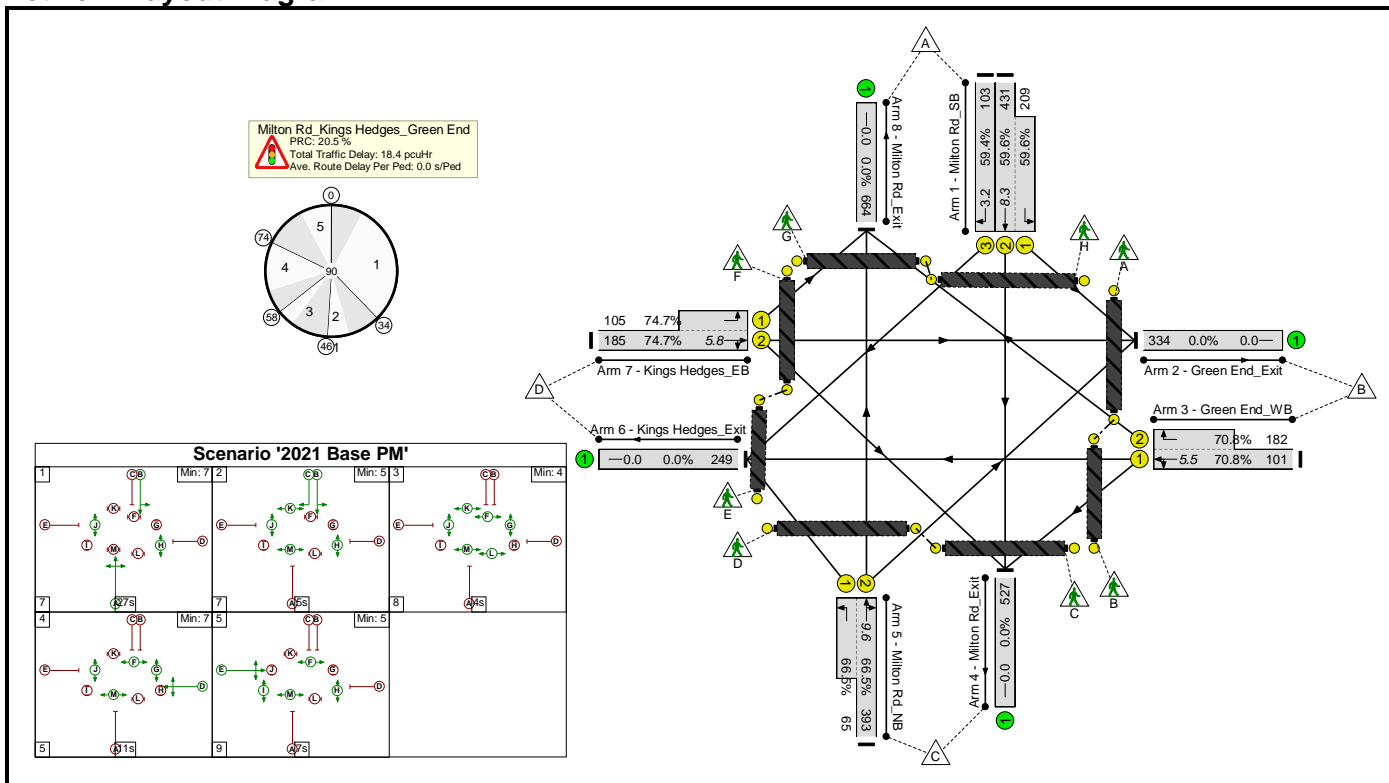

Basic Results Summary

Network Results

Item	Lane Description	Lane Type	Full Phase	Arrow Phase	Num Greens	Total Green (s)	Arrow Green (s)	Demand Flow (pcu)	Sat Flow (pcu/Hr)	Capacity (pcu)	Deg Sat (%)	Turners In Gaps (pcu)	Turners When Unopposed (pcu)	Turners In Intergreen (pcu)	Total Delay (pcuHr)	Av. Delay Per PCU (s/pcu)	Mean Max Queue (pcu)	Item
Network: Milton Road/King Hedges Road/Green End Road	-	-	-		-	-	-	-	-	-	74.7%	0	0	0	18.4	-	-	Network: Milton Road/King Hedges Road/Green End Road
Milton Rd_Kings Hedges_Green End	-	-	-		-	-	-	-	-	-	74.7%	0	0	0	18.4	-	-	Milton Rd_Kings Hedges_Green End
1/2+1/1	Milton Rd_SB Left Ahead	U	B		1	39	-	640	2055:1826	723+351	59.6 : 59.6%	-	-	-	3.8	21.1	8.3	1/2+1/1
1/3	Milton Rd_SB Right	U	C		1	7	-	103	1951	173	59.4%	-	-	-	1.8	64.5	3.2	1/3
3/1+3/2	Green End_WB Left Ahead Right	U	D		1	11	-	283	1912:1971	143+257	70.8 : 70.8%	-	-	-	4.1	51.8	5.5	3/1+3/2
5/2+5/1	Milton Rd_NB Right Left Ahead	U	A		1	27	-	458	2074:1798	591+98	66.5 : 66.5%	-	-	-	4.3	33.7	9.6	5/2+5/1
7/2+7/1	Kings Hedges_EB Ahead Right Left	U	E		1	11	-	290	2042:1811	248+141	74.7 : 74.7%	-	-	-	4.4	54.5	5.8	7/2+7/1
Ped Link: P1	Unnamed Ped Link	-	G		1	20	-	0	-	16000	0.0%	-	-	-	0.0	0.0	0.0	Ped Link: P1
Ped Link: P2	Unnamed Ped Link	-	H		1	57	-	0	-	45600	0.0%	-	-	-	0.0	0.0	0.0	Ped Link: P2
Ped Link: P3	Unnamed Ped Link	-	L		1	5	-	0	-	4000	0.0%	-	-	-	0.0	0.0	0.0	Ped Link: P3
Ped Link: P4	Unnamed Ped Link	-	M		1	51	-	0	-	40800	0.0%	-	-	-	0.0	0.0	0.0	Ped Link: P4
Ped Link: P5	Unnamed Ped Link	-	J		1	68	-	0	-	54400	0.0%	-	-	-	0.0	0.0	0.0	Ped Link: P5

Basic Results Summary

Ped Link: P6	Unnamed Ped Link	-	I		1	7	-	0	-	5600	0.0%	-	-	-	0.0	0.0	0.0	Ped Link: P6
Ped Link: P7	Unnamed Ped Link	-	K		1	17	-	0	-	13600	0.0%	-	-	-	0.0	0.0	0.0	Ped Link: P7
Ped Link: P8	Unnamed Ped Link	-	F		1	39	-	0	-	31200	0.0%	-	-	-	0.0	0.0	0.0	Ped Link: P8
		C1		PRC for Signalled Lanes (%):		20.5		Total Delay for Signalled Lanes (pcuHr):		18.36		Cycle Time (s):		90				
				PRC Over All Lanes (%):		20.5		Total Delay Over All Lanes(pcuHr):		18.36								

Basic Results Summary

Scenario 3: '2026 Base AM' (FG3: '2026 Base AM', Plan 1: 'Network Control Plan 1 AM')

Network Layout Diagram

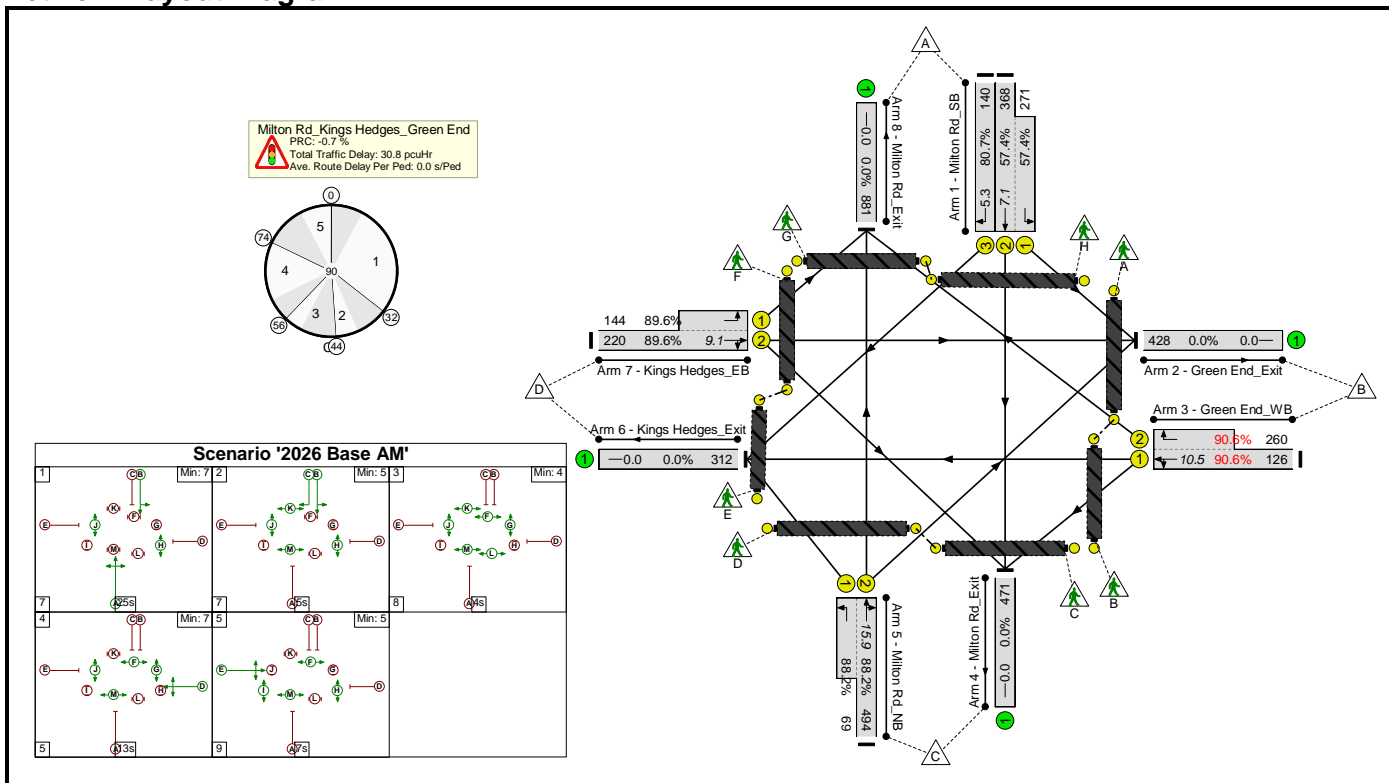

Basic Results Summary

Network Results

Item	Lane Description	Lane Type	Full Phase	Arrow Phase	Num Greens	Total Green (s)	Arrow Green (s)	Demand Flow (pcu)	Sat Flow (pcu/Hr)	Capacity (pcu)	Deg Sat (%)	Turners In Gaps (pcu)	Turners When Unopposed (pcu)	Turners In Intergreen (pcu)	Total Delay (pcuHr)	Av. Delay Per PCU (s/pcu)	Mean Max Queue (pcu)	Item
Network: Milton Road/King Hedges Road/Green End Road	-	-	-		-	-	-	-	-	-	90.6%	0	0	0	30.8	-	-	Network: Milton Road/King Hedges Road/Green End Road
Milton Rd_Kings Hedges_Green End	-	-	-		-	-	-	-	-	-	90.6%	0	0	0	30.8	-	-	Milton Rd_Kings Hedges_Green End
1/2+1/1	Milton Rd_SB Left Ahead	U	B		1	37	-	639	2055:1826	641+472	57.4 : 57.4%	-	-	-	3.9	21.8	7.1	1/2+1/1
1/3	Milton Rd_SB Right	U	C		1	7	-	140	1951	173	80.7%	-	-	-	3.4	88.7	5.3	1/3
3/1+3/2	Green End_WB Left Ahead Right	U	D		1	13	-	386	1914:1971	139+287	90.6 : 90.6%	-	-	-	7.9	73.7	10.5	3/1+3/2
5/2+5/1	Milton Rd_NB Right Left Ahead	U	A		1	25	-	563	2075:1798	560+78	88.2 : 88.2%	-	-	-	8.1	51.8	15.9	5/2+5/1
7/2+7/1	Kings Hedges_EB Ahead Right Left	U	E		1	11	-	364	2049:1811	246+161	89.6 : 89.6%	-	-	-	7.4	73.7	9.1	7/2+7/1
Ped Link: P1	Unnamed Ped Link	-	G		1	22	-	0	-	17600	0.0%	-	-	-	0.0	0.0	0.0	Ped Link: P1
Ped Link: P2	Unnamed Ped Link	-	H		1	55	-	0	-	44000	0.0%	-	-	-	0.0	0.0	0.0	Ped Link: P2
Ped Link: P3	Unnamed Ped Link	-	L		1	5	-	0	-	4000	0.0%	-	-	-	0.0	0.0	0.0	Ped Link: P3
Ped Link: P4	Unnamed Ped Link	-	M		1	53	-	0	-	42400	0.0%	-	-	-	0.0	0.0	0.0	Ped Link: P4
Ped Link: P5	Unnamed Ped Link	-	J		1	68	-	0	-	54400	0.0%	-	-	-	0.0	0.0	0.0	Ped Link: P5

Basic Results Summary

Ped Link: P6	Unnamed Ped Link	-	I		1	7	-	0	-	5600	0.0%	-	-	-	0.0	0.0	0.0	Ped Link: P6
Ped Link: P7	Unnamed Ped Link	-	K		1	17	-	0	-	13600	0.0%	-	-	-	0.0	0.0	0.0	Ped Link: P7
Ped Link: P8	Unnamed Ped Link	-	F		1	41	-	0	-	32800	0.0%	-	-	-	0.0	0.0	0.0	Ped Link: P8
		C1			PRC for Signalled Lanes (%):		-0.7		Total Delay for Signalled Lanes (pcuHr):		30.77		Cycle Time (s):		90			
					PRC Over All Lanes (%):		-0.7		Total Delay Over All Lanes(pcuHr):		30.77							

Basic Results Summary

Scenario 4: '2026 Base PM' (FG4: '2026 Base PM', Plan 1: 'Network Control Plan 1 AM')

Network Layout Diagram

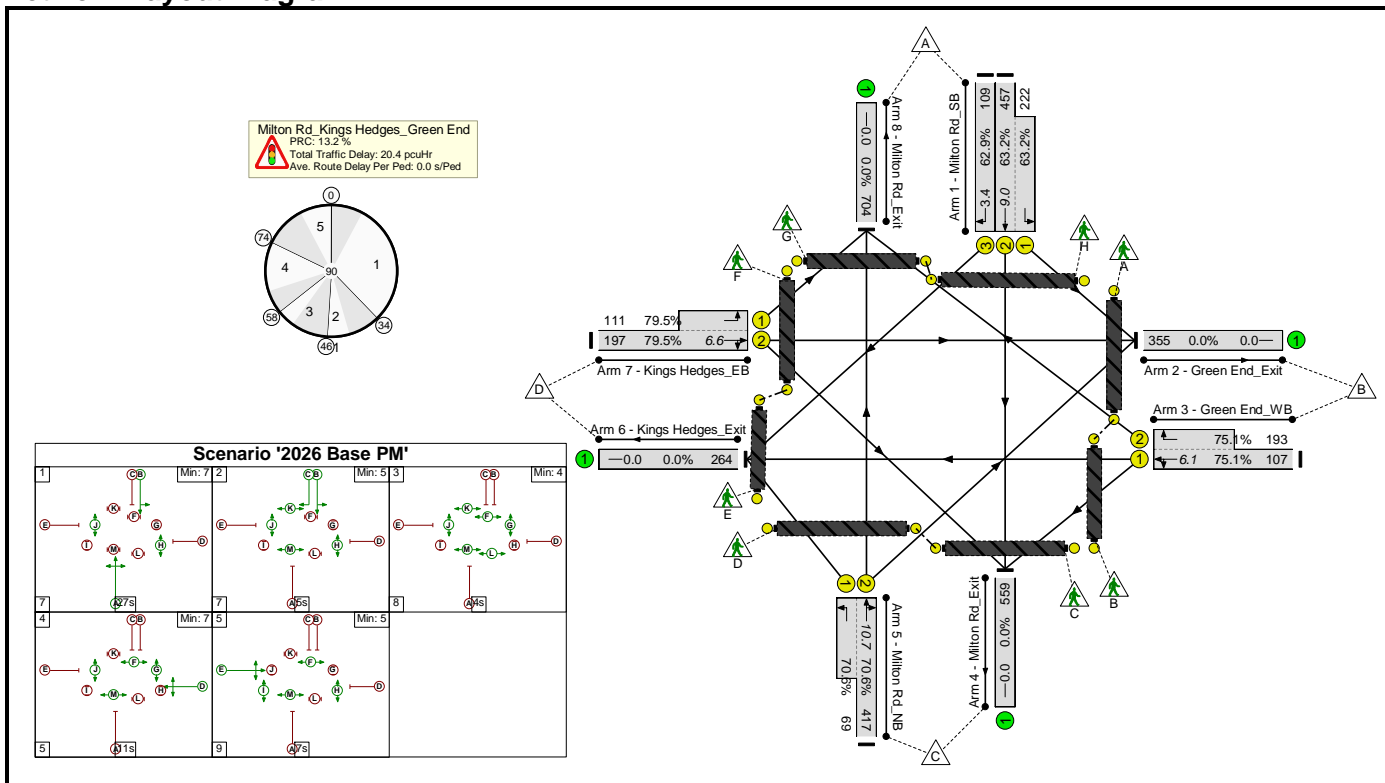

Basic Results Summary

Network Results

Item	Lane Description	Lane Type	Full Phase	Arrow Phase	Num Greens	Total Green (s)	Arrow Green (s)	Demand Flow (pcu)	Sat Flow (pcu/Hr)	Capacity (pcu)	Deg Sat (%)	Turners In Gaps (pcu)	Turners When Unopposed (pcu)	Turners In Intergreen (pcu)	Total Delay (pcuHr)	Av. Delay Per PCU (s/pcu)	Mean Max Queue (pcu)	Item
Network: Milton Road/King Hedges Road/Green End Road	-	-	-		-	-	-	-	-	-	79.5%	0	0	0	20.4	-	-	Network: Milton Road/King Hedges Road/Green End Road
Milton Rd_Kings Hedges_Green End	-	-	-		-	-	-	-	-	-	79.5%	0	0	0	20.4	-	-	Milton Rd_Kings Hedges_Green End
1/2+1/1	Milton Rd_SB Left Ahead	U	B		1	39	-	679	2055:1826	723+351	63.2 : 63.2%	-	-	-	4.1	21.7	9.0	1/2+1/1
1/3	Milton Rd_SB Right	U	C		1	7	-	109	1951	173	62.9%	-	-	-	2.0	66.8	3.4	1/3
3/1+3/2	Green End_WB Left Ahead Right	U	D		1	11	-	300	1912:1971	142+257	75.1 : 75.1%	-	-	-	4.5	54.5	6.1	3/1+3/2
5/2+5/1	Milton Rd_NB Right Left Ahead	U	A		1	27	-	486	2074:1798	591+98	70.6 : 70.6%	-	-	-	4.8	35.2	10.7	5/2+5/1
7/2+7/1	Kings Hedges_EB Ahead Right Left	U	E		1	11	-	308	2042:1811	248+140	79.5 : 79.5%	-	-	-	5.0	58.6	6.6	7/2+7/1
Ped Link: P1	Unnamed Ped Link	-	G		1	20	-	0	-	16000	0.0%	-	-	-	0.0	0.0	0.0	Ped Link: P1
Ped Link: P2	Unnamed Ped Link	-	H		1	57	-	0	-	45600	0.0%	-	-	-	0.0	0.0	0.0	Ped Link: P2
Ped Link: P3	Unnamed Ped Link	-	L		1	5	-	0	-	4000	0.0%	-	-	-	0.0	0.0	0.0	Ped Link: P3
Ped Link: P4	Unnamed Ped Link	-	M		1	51	-	0	-	40800	0.0%	-	-	-	0.0	0.0	0.0	Ped Link: P4
Ped Link: P5	Unnamed Ped Link	-	J		1	68	-	0	-	54400	0.0%	-	-	-	0.0	0.0	0.0	Ped Link: P5

Basic Results Summary

Ped Link: P6	Unnamed Ped Link	-	I		1	7	-	0	-	5600	0.0%	-	-	-	0.0	0.0	0.0	Ped Link: P6
Ped Link: P7	Unnamed Ped Link	-	K		1	17	-	0	-	13600	0.0%	-	-	-	0.0	0.0	0.0	Ped Link: P7
Ped Link: P8	Unnamed Ped Link	-	F		1	39	-	0	-	31200	0.0%	-	-	-	0.0	0.0	0.0	Ped Link: P8
		C1			PRC for Signalled Lanes (%):		13.2		Total Delay for Signalled Lanes (pcuHr):		20.43		Cycle Time (s):		90			
					PRC Over All Lanes (%):		13.2		Total Delay Over All Lanes(pcuHr):		20.43							

Basic Results Summary

Scenario 11: '2026 Base + Construction AM' (FG17: '2026 Base + Construction AM', Plan 1: 'Network Control Plan 1 AM')

Network Layout Diagram

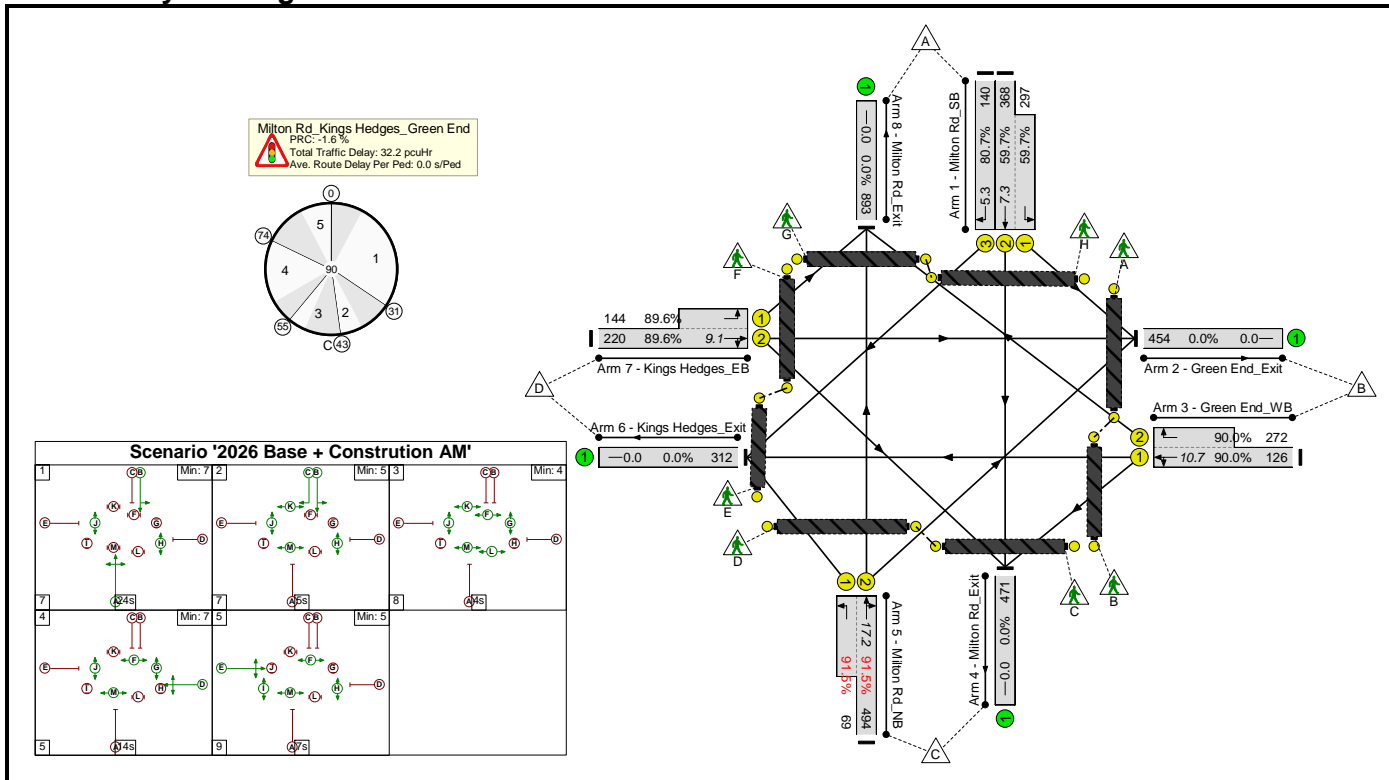

Basic Results Summary

Network Results

Item	Lane Description	Lane Type	Full Phase	Arrow Phase	Num Greens	Total Green (s)	Arrow Green (s)	Demand Flow (pcu)	Sat Flow (pcu/Hr)	Capacity (pcu)	Deg Sat (%)	Turners In Gaps (pcu)	Turners When Unopposed (pcu)	Turners In Intergreen (pcu)	Total Delay (pcuHr)	Av. Delay Per PCU (s/pcu)	Mean Max Queue (pcu)	Item
Network: Milton Road/King Hedges Road/Green End Road	-	-	-		-	-	-	-	-	-	91.5%	0	0	0	32.2	-	-	Network: Milton Road/King Hedges Road/Green End Road
Milton Rd_Kings Hedges_Green End	-	-	-		-	-	-	-	-	-	91.5%	0	0	0	32.2	-	-	Milton Rd_Kings Hedges_Green End
1/2+1/1	Milton Rd_SB Left Ahead	U	B		1	36	-	665	2055:1826	617+498	59.7 : 59.7%	-	-	-	4.2	22.8	7.3	1/2+1/1
1/3	Milton Rd_SB Right	U	C		1	7	-	140	1951	173	80.7%	-	-	-	3.4	88.7	5.3	1/3
3/1+3/2	Green End_WB Left Ahead Right	U	D		1	14	-	398	1914:1971	140+302	90.0 : 90.0%	-	-	-	7.7	70.1	10.7	3/1+3/2
5/2+5/1	Milton Rd_NB Right Left Ahead	U	A		1	24	-	563	2075:1798	540+75	91.5 : 91.5%	-	-	-	9.4	60.0	17.2	5/2+5/1
7/2+7/1	Kings Hedges_EB Ahead Right Left	U	E		1	11	-	364	2049:1811	246+161	89.6 : 89.6%	-	-	-	7.4	73.7	9.1	7/2+7/1
Ped Link: P1	Unnamed Ped Link	-	G		1	23	-	0	-	18400	0.0%	-	-	-	0.0	0.0	0.0	Ped Link: P1
Ped Link: P2	Unnamed Ped Link	-	H		1	54	-	0	-	43200	0.0%	-	-	-	0.0	0.0	0.0	Ped Link: P2
Ped Link: P3	Unnamed Ped Link	-	L		1	5	-	0	-	4000	0.0%	-	-	-	0.0	0.0	0.0	Ped Link: P3
Ped Link: P4	Unnamed Ped Link	-	M		1	54	-	0	-	43200	0.0%	-	-	-	0.0	0.0	0.0	Ped Link: P4
Ped Link: P5	Unnamed Ped Link	-	J		1	68	-	0	-	54400	0.0%	-	-	-	0.0	0.0	0.0	Ped Link: P5

Basic Results Summary

Ped Link: P6	Unnamed Ped Link	-	I		1	7	-	0	-	5600	0.0%	-	-	-	0.0	0.0	0.0	Ped Link: P6
Ped Link: P7	Unnamed Ped Link	-	K		1	17	-	0	-	13600	0.0%	-	-	-	0.0	0.0	0.0	Ped Link: P7
Ped Link: P8	Unnamed Ped Link	-	F		1	42	-	0	-	33600	0.0%	-	-	-	0.0	0.0	0.0	Ped Link: P8
		C1			PRC for Signalled Lanes (%):		-1.6		Total Delay for Signalled Lanes (pcuHr):		32.24		Cycle Time (s):		90			
					PRC Over All Lanes (%):		-1.6		Total Delay Over All Lanes(pcuHr):		32.24							

Basic Results Summary

Scenario 12: '2026 Base + Construction PM' (FG18: '2026 Base + Construction PM', Plan 1: 'Network Control Plan 1 AM')

Network Layout Diagram

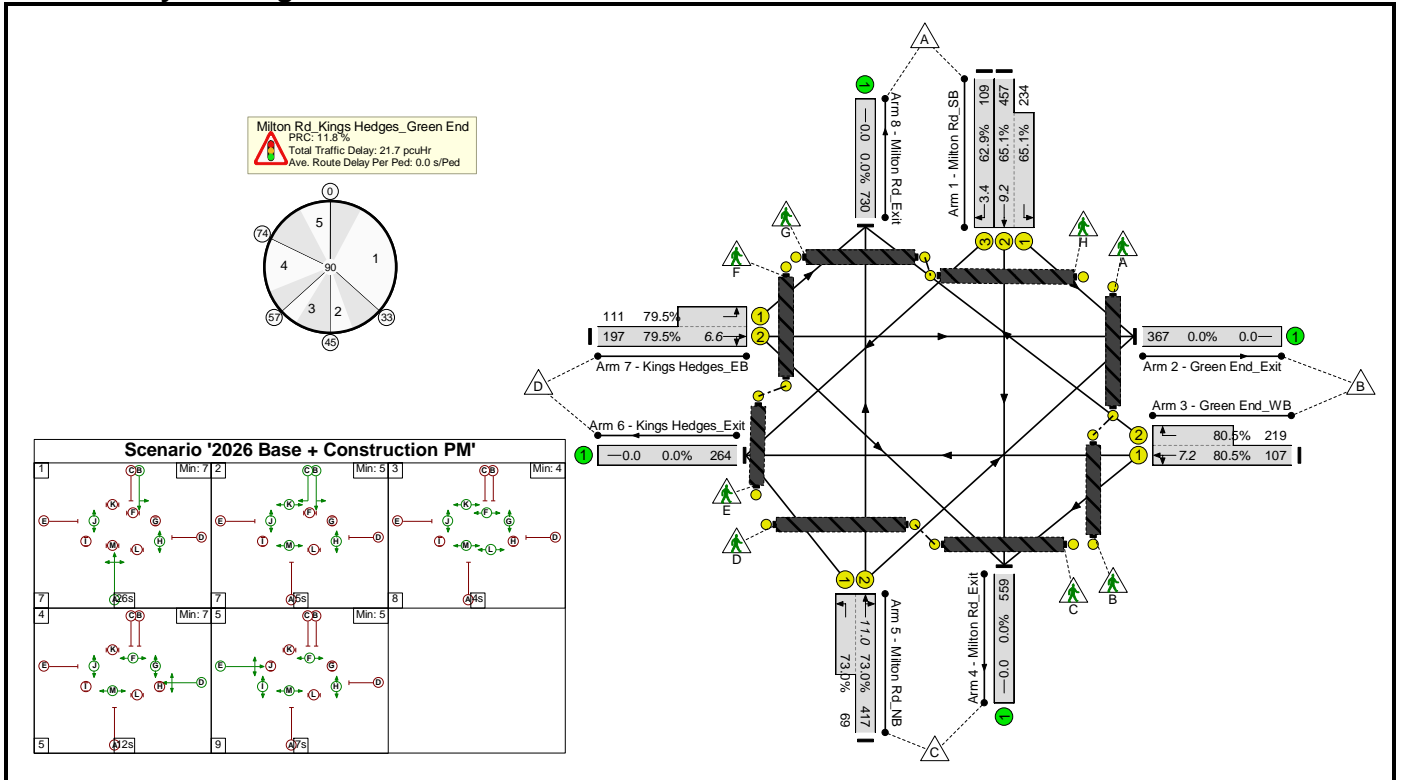

Basic Results Summary

Network Results

Item	Lane Description	Lane Type	Full Phase	Arrow Phase	Num Greens	Total Green (s)	Arrow Green (s)	Demand Flow (pcu)	Sat Flow (pcu/Hr)	Capacity (pcu)	Deg Sat (%)	Turners In Gaps (pcu)	Turners When Unopposed (pcu)	Turners In Intergreen (pcu)	Total Delay (pcuHr)	Av. Delay Per PCU (s/pcu)	Mean Max Queue (pcu)	Item
Network: Milton Road/King Hedges Road/Green End Road	-	-	-		-	-	-	-	-	-	80.5%	0	0	0	21.7	-	-	Network: Milton Road/King Hedges Road/Green End Road
Milton Rd_Kings Hedges_Green End	-	-	-		-	-	-	-	-	-	80.5%	0	0	0	21.7	-	-	Milton Rd_Kings Hedges_Green End
1/2+1/1	Milton Rd_SB Left Ahead	U	B		1	38	-	691	2055:1826	702+359	65.1 : 65.1%	-	-	-	4.4	22.8	9.2	1/2+1/1
1/3	Milton Rd_SB Right	U	C		1	7	-	109	1951	173	62.9%	-	-	-	2.0	66.8	3.4	1/3
3/1+3/2	Green End_WB Left Ahead Right	U	D		1	12	-	326	1912:1971	133+272	80.5 : 80.5%	-	-	-	5.3	58.0	7.2	3/1+3/2
5/2+5/1	Milton Rd_NB Right Left Ahead	U	A		1	26	-	486	2074:1798	571+95	73.0 : 73.0%	-	-	-	5.0	37.2	11.0	5/2+5/1
7/2+7/1	Kings Hedges_EB Ahead Right Left	U	E		1	11	-	308	2042:1811	248+140	79.5 : 79.5%	-	-	-	5.0	58.6	6.6	7/2+7/1
Ped Link: P1	Unnamed Ped Link	-	G		1	21	-	0	-	16800	0.0%	-	-	-	0.0	0.0	0.0	Ped Link: P1
Ped Link: P2	Unnamed Ped Link	-	H		1	56	-	0	-	44800	0.0%	-	-	-	0.0	0.0	0.0	Ped Link: P2
Ped Link: P3	Unnamed Ped Link	-	L		1	5	-	0	-	4000	0.0%	-	-	-	0.0	0.0	0.0	Ped Link: P3
Ped Link: P4	Unnamed Ped Link	-	M		1	52	-	0	-	41600	0.0%	-	-	-	0.0	0.0	0.0	Ped Link: P4
Ped Link: P5	Unnamed Ped Link	-	J		1	68	-	0	-	54400	0.0%	-	-	-	0.0	0.0	0.0	Ped Link: P5

Basic Results Summary

Ped Link: P6	Unnamed Ped Link	-	I		1	7	-	0	-	5600	0.0%	-	-	-	0.0	0.0	0.0	Ped Link: P6
Ped Link: P7	Unnamed Ped Link	-	K		1	17	-	0	-	13600	0.0%	-	-	-	0.0	0.0	0.0	Ped Link: P7
Ped Link: P8	Unnamed Ped Link	-	F		1	40	-	0	-	32000	0.0%	-	-	-	0.0	0.0	0.0	Ped Link: P8
		C1			PRC for Signalled Lanes (%):		11.8		Total Delay for Signalled Lanes (pcuHr):		21.68		Cycle Time (s):		90			
					PRC Over All Lanes (%):		11.8		Total Delay Over All Lanes(pcuHr):		21.68							

8 Water Lane / High Street / Green End Road (Junctions 9)

- 2021 Baseline AM
- 2021 Baseline PM
- Construction Year 3 (2026) – Future Baseline AM
- Construction Year 3 (2026) – Future Baseline PM
- Construction Year 3 (2026) – Construction Peak AM
- Construction Year 3 (2026) – Construction Peak PM

Junctions 9

ARCADY 9 - Roundabout Module

Version: 9.5.0.6896
© Copyright TRL Limited, 2018

For sales and distribution information, program advice and maintenance, contact TRL:
+44 (0)1344 379777 software@trl.co.uk www.trlsoftware.co.uk

The users of this computer program for the solution of an engineering problem are in no way relieved of their responsibility for the correctness of the solution

Filename: Green End Rd_Water Lane (1).j9

Path: C:\Users\BAS102795\OneDrive - Mott MacDonald\Projects\Camb linsig\Modelling\7_Green End Rd_Water Ln

Report generation date: 09/02/2024 14:12:23

»2021 Base, AM

»2021 Base, PM

»2026 Base , AM

»2026 Base, PM

»2026 Base + Construction, AM

»2026 Base + Construction, PM

Summary of junction performance

	AM				PM			
	Queue (PCU)	Delay (s)	RFC	LOS	Queue (PCU)	Delay (s)	RFC	LOS
2021 Base								
Arm 1	0.9	10.84	0.48	B	0.6	9.33	0.38	A
Arm 2	0.8	12.30	0.43	B	0.4	9.13	0.30	A
Arm 3	0.3	5.42	0.21	A	0.4	5.40	0.26	A
2026 Base								
Arm 1	1.1	11.61	0.51	B	0.7	9.81	0.41	A
Arm 2	0.9	13.29	0.46	B	0.5	9.52	0.32	A
Arm 3	0.3	5.53	0.23	A	0.4	5.54	0.28	A
2028								
Arm 1	1.1	11.88	0.52	B	0.7	10.00	0.42	B
Arm 2	0.9	13.67	0.47	B	0.5	9.69	0.33	A
Arm 3	0.3	5.57	0.23	A	0.4	5.60	0.28	A

2033								
Arm 1	1.2	12.64	0.55	B	0.8	10.51	0.44	B
Arm 2	1.0	14.78	0.51	B	0.6	10.15	0.35	B
Arm 3	0.3	5.71	0.25	A	0.4	5.76	0.30	A
2038								
Arm 1	1.4	13.48	0.57	B	0.8	11.00	0.46	B
Arm 2	1.2	16.09	0.54	C	0.6	10.50	0.37	B
Arm 3	0.4	5.86	0.26	A	0.5	5.89	0.31	A
2026 Base + Construction								
Arm 1	1.2	12.51	0.53	B	0.9	11.11	0.45	B
Arm 2	0.9	13.70	0.47	B	0.5	10.01	0.33	B
Arm 3	0.4	5.98	0.26	A	0.4	5.85	0.29	A
2028 + Decommissioning								
Arm 1	1.1	11.88	0.52	B	0.7	10.00	0.42	B
Arm 2	0.9	13.67	0.47	B	0.5	9.69	0.33	A
Arm 3	0.3	5.57	0.23	A	0.4	5.60	0.28	A
2033 + Operation								
Arm 1	1.2	12.64	0.55	B	0.8	10.51	0.44	B
Arm 2	1.0	14.78	0.51	B	0.6	10.15	0.35	B
Arm 3	0.3	5.71	0.25	A	0.4	5.76	0.30	A
2038 + Operation								
Arm 1	1.4	13.48	0.57	B	0.8	11.00	0.46	B
Arm 2	1.2	16.09	0.54	C	0.6	10.50	0.37	B
Arm 3	0.4	5.86	0.26	A	0.5	5.89	0.31	A

Values shown are the highest values encountered over all time segments. Delay is the maximum value of average delay per arriving vehicle.

File summary

File Description

Title	Green End Rd_Water Lane
Location	Cambridge
Site number	
Date	22/03/2022
Version	0.1
Status	(new file)
Identifier	
Client	Anglian Water
Jobnumber	
Enumerator	MOTTMAC\srcv_lond_trans
Description	

Units

Distance units	Speed units	Traffic units input	Traffic units results	Flow units	Average delay units	Total delay units	Rate of delay units
m	kph	PCU	PCU	perHour	s	-Min	perMin

Analysis Options

Mini-roundabout model	Calculate Queue Percentiles	Calculate residual capacity	RFC Threshold	Average Delay threshold (s)	Queue threshold (PCU)
JUNCTIONS 9			0.85	36.00	20.00

Demand Set Summary

ID	Scenario name	Time Period name	Traffic profile type	Start time (HH:mm)	Finish time (HH:mm)	Time segment length (min)
D1	2021 Base	AM	ONE HOUR	08:00	09:30	15
D2	2021 Base	PM	ONE HOUR	17:00	18:30	15
D3	2026 Base	AM	ONE HOUR	08:00	09:30	15
D4	2026 Base	PM	ONE HOUR	17:00	18:30	15
D5	2028	AM	ONE HOUR	08:00	09:30	15
D6	2028	PM	ONE HOUR	17:00	18:30	15
D7	2033	AM	ONE HOUR	08:00	09:30	15
D8	2033	PM	ONE HOUR	17:00	18:30	15
D9	2038	AM	ONE HOUR	08:00	09:30	15
D10	2038	PM	ONE HOUR	17:00	18:30	15
D11	2026 Base + Construction	AM	ONE HOUR	08:00	09:30	15
D12	2026 Base + Construction	PM	ONE HOUR	17:00	18:30	15
D13	2028 + Decommissioning	AM	ONE HOUR	08:00	09:30	15
D14	2028 + Decommissioning	PM	ONE HOUR	17:00	18:30	15
D15	2033 + Operation	AM	ONE HOUR	08:00	09:30	15
D16	2033 + Operation	PM	ONE HOUR	17:00	18:30	15
D17	2038 + Operation	AM	ONE HOUR	08:00	09:30	15
D18	2038 + Operation	PM	ONE HOUR	17:00	18:30	15

Analysis Set Details

ID	Network flow scaling factor (%)
A1	100.000

2021 Base, AM

Data Errors and Warnings

No errors or warnings

Junction Network

Junctions

Junction	Name	Junction type	Use circulating lanes	Arm order	Junction Delay (s)	Junction LOS
1	untitled	Mini-roundabout		1, 2, 3	9.89	A

Junction Network Options

Driving side	Lighting	Road surface	In London
Left	Normal/unknown	Normal/unknown	

Arms

Arms

Arm	Name	Description
1	Water Lane	
2	High St	
3	Green End Rd	

Mini Roundabout Geometry

Arm	Approach road half-width (m)	Minimum approach road half-width (m)	Entry width (m)	Effective flare length (m)	Distance to next arm (m)	Entry corner kerb line distance (m)	Gradient over 50m (%)	Kerbed central island
-----	------------------------------	--------------------------------------	-----------------	----------------------------	--------------------------	-------------------------------------	-----------------------	-----------------------

1	2.30	2.00	3.00	4.0	8.00	7.75	0.0	
2	3.50	2.00	3.20	1.2	15.90	17.00	0.0	
3	3.00	3.00	3.00	0.0	16.00	15.40	0.0	

Zebra Crossings

Arm	Space between crossing and junction entry (Zebra) (PCU)	Vehicles queueing on exit (Zebra) (PCU)	Central Refuge	Crossing data type	Crossing length (m)	Crossing time (s)
1	1.00	1.00		Distance	5.30	3.79
2	1.00	1.00		Distance	6.00	4.29
3	1.00	1.00		Distance	9.00	6.43

Slope / Intercept / Capacity

Roundabout Slope and Intercept used in model

Arm	Final slope	Final intercept (PCU/hr)
1	0.574	696
2	0.631	684
3	0.620	969

The slope and intercept shown above include any corrections and adjustments.

Traffic Demand

Demand Set Details

ID	Scenario name	Time Period name	Traffic profile type	Start time (HH:mm)	Finish time (HH:mm)	Time segment length (min)
D1	2021 Base	AM	ONE HOUR	08:00	09:30	15

Vehicle mix source	PCU Factor for a HV (PCU)
HV Percentages	2.00

Demand overview (Traffic)

Arm	Linked arm	Use O-D data	Average Demand (PCU/hr)	Scaling Factor (%)
1		✓	285	100.000
2		✓	207	100.000
3		✓	172	100.000

Demand overview (Pedestrians)

Arm	Average pedestrian flow (Ped/hr)
1	10.00
2	10.00
3	10.00

Origin-Destination Data

Demand (PCU/hr)

	To			
	1	2	3	
From	1	0	92	193
	2	112	0	95
	3	111	61	0

Vehicle Mix

Heavy Vehicle Percentages

		To		
		1	2	3
From	1	0	3	3
	2	4	0	5
	3	7	2	0

Results

Results Summary for whole modelled period

Arm	Max RFC	Max Delay (s)	Max Queue (PCU)	Max LOS
1	0.48	10.84	0.9	B
2	0.43	12.30	0.8	B
3	0.21	5.42	0.3	A

Main Results for each time segment

08:00 - 08:15

Arm	Total Demand (PCU/hr)	Circulating flow (PCU/hr)	Pedestrian demand (Ped/hr)	Capacity (PCU/hr)	RFC	Throughput (PCU/hr)	End queue (PCU)	Delay (s)	Unsignalised level of service
1	215	46	7.53	669	0.321	213	0.5	8.094	A
2	156	144	7.53	585	0.266	154	0.4	8.705	A
3	129	84	7.53	915	0.141	129	0.2	4.811	A

08:15 - 08:30

Arm	Total Demand (PCU/hr)	Circulating flow (PCU/hr)	Pedestrian demand (Ped/hr)	Capacity (PCU/hr)	RFC	Throughput (PCU/hr)	End queue (PCU)	Delay (s)	Unsignalised level of service
1	256	55	8.99	663	0.386	256	0.6	9.079	A
2	186	173	8.99	563	0.330	186	0.5	9.940	A
3	155	100	8.99	904	0.171	154	0.2	5.052	A

08:30 - 08:45

Arm	Total Demand (PCU/hr)	Circulating flow (PCU/hr)	Pedestrian demand (Ped/hr)	Capacity (PCU/hr)	RFC	Throughput (PCU/hr)	End queue (PCU)	Delay (s)	Unsignalised level of service
1	314	67	11.01	656	0.479	313	0.9	10.775	B
2	228	212	11.01	534	0.427	227	0.8	12.198	B
3	189	123	11.01	888	0.213	189	0.3	5.415	A

08:45 - 09:00

Arm	Total Demand (PCU/hr)	Circulating flow (PCU/hr)	Pedestrian demand (Ped/hr)	Capacity (PCU/hr)	RFC	Throughput (PCU/hr)	End queue (PCU)	Delay (s)	Unsignalised level of service
1	314	67	11.01	656	0.479	314	0.9	10.845	B
2	228	212	11.01	534	0.427	228	0.8	12.298	B
3	189	123	11.01	887	0.213	189	0.3	5.423	A

09:00 - 09:15

Arm	Total Demand (PCU/hr)	Circulating flow (PCU/hr)	Pedestrian demand (Ped/hr)	Capacity (PCU/hr)	RFC	Throughput (PCU/hr)	End queue (PCU)	Delay (s)	Unsignalised level of service
1	256	55	8.99	663	0.386	257	0.7	9.160	A
2	186	174	8.99	562	0.331	187	0.5	10.045	B
3	155	101	8.99	903	0.171	155	0.2	5.063	A

09:15 - 09:30

Arm	Total Demand (PCU/hr)	Circulating flow (PCU/hr)	Pedestrian demand (Ped/hr)	Capacity (PCU/hr)	RFC	Throughput (PCU/hr)	End queue (PCU)	Delay (s)	Unsignalised level of service
1	215	46	7.53	669	0.321	215	0.5	8.188	A
2	156	146	7.53	584	0.267	156	0.4	8.814	A
3	129	85	7.53	914	0.142	130	0.2	4.827	A

2021 Base, PM

Data Errors and Warnings

No errors or warnings

Junction Network

Junctions

Junction	Name	Junction type	Use circulating lanes	Arm order	Junction Delay (s)	Junction LOS
1	untitled	Mini-roundabout		1, 2, 3	7.83	A

Junction Network Options

Driving side	Lighting	Road surface	In London
Left	Normal/unknown	Normal/unknown	

Traffic Demand

Demand Set Details

ID	Scenario name	Time Period name	Traffic profile type	Start time (HH:mm)	Finish time (HH:mm)	Time segment length (min)
D2	2021 Base	PM	ONE HOUR	17:00	18:30	15

Vehicle mix source	PCU Factor for a HV (PCU)
HV Percentages	2.00

Demand overview (Traffic)

Arm	Linked arm	Use O-D data	Average Demand (PCU/hr)	Scaling Factor (%)
1		✓	215	100.000
2		✓	159	100.000
3		✓	216	100.000

Demand overview (Pedestrians)

Arm	Average pedestrian flow (Ped/hr)
1	10.00
2	10.00
3	10.00

Origin-Destination Data

Demand (PCU/hr)

From	To		
	1	2	3
1	0	86	129
2	70	0	89
3	105	111	0

Vehicle Mix

Heavy Vehicle Percentages

From	To		
	1	2	3
1	0	0	0
2	2	0	5
3	1	3	0

Results

Results Summary for whole modelled period

Arm	Max RFC	Max Delay (s)	Max Queue (PCU)	Max LOS
1	0.38	9.33	0.6	A
2	0.30	9.13	0.4	A
3	0.26	5.40	0.4	A

Main Results for each time segment

17:00 - 17:15

Arm	Total Demand (PCU/hr)	Circulating flow (PCU/hr)	Pedestrian demand (Ped/hr)	Capacity (PCU/hr)	RFC	Throughput (PCU/hr)	End queue (PCU)	Delay (s)	Unsignalised level of service
1	162	83	7.53	647	0.250	161	0.3	7.384	A
2	120	96	7.53	618	0.194	119	0.2	7.466	A
3	163	52	7.53	935	0.174	162	0.2	4.742	A

17:15 - 17:30

Arm	Total Demand (PCU/hr)	Circulating flow (PCU/hr)	Pedestrian demand (Ped/hr)	Capacity (PCU/hr)	RFC	Throughput (PCU/hr)	End queue (PCU)	Delay (s)	Unsignalised level of service
1	193	100	8.99	637	0.304	193	0.4	8.104	A
2	143	116	8.99	603	0.237	143	0.3	8.092	A
3	194	63	8.99	928	0.209	194	0.3	5.000	A

17:30 - 17:45

Arm	Total Demand (PCU/hr)	Circulating flow (PCU/hr)	Pedestrian demand (Ped/hr)	Capacity (PCU/hr)	RFC	Throughput (PCU/hr)	End queue (PCU)	Delay (s)	Unsignalised level of service
-----	-----------------------	---------------------------	----------------------------	-------------------	-----	---------------------	-----------------	-----------	-------------------------------

1	237	122	11.01	623	0.380	236	0.6	9.292	A
2	175	142	11.01	584	0.300	175	0.4	9.104	A
3	238	77	11.01	918	0.259	237	0.4	5.390	A

17:45 - 18:00

Arm	Total Demand (PCU/hr)	Circulating flow (PCU/hr)	Pedestrian demand (Ped/hr)	Capacity (PCU/hr)	RFC	Throughput (PCU/hr)	End queue (PCU)	Delay (s)	Unsignalised level of service
1	237	122	11.01	623	0.380	237	0.6	9.326	A
2	175	142	11.01	584	0.300	175	0.4	9.132	A
3	238	77	11.01	918	0.259	238	0.4	5.396	A

18:00 - 18:15

Arm	Total Demand (PCU/hr)	Circulating flow (PCU/hr)	Pedestrian demand (Ped/hr)	Capacity (PCU/hr)	RFC	Throughput (PCU/hr)	End queue (PCU)	Delay (s)	Unsignalised level of service
1	193	100	8.99	637	0.304	194	0.4	8.147	A
2	143	116	8.99	603	0.237	143	0.3	8.128	A
3	194	63	8.99	928	0.209	195	0.3	5.008	A

18:15 - 18:30

Arm	Total Demand (PCU/hr)	Circulating flow (PCU/hr)	Pedestrian demand (Ped/hr)	Capacity (PCU/hr)	RFC	Throughput (PCU/hr)	End queue (PCU)	Delay (s)	Unsignalised level of service
1	162	84	7.53	647	0.250	162	0.3	7.439	A
2	120	97	7.53	617	0.194	120	0.3	7.514	A
3	163	53	7.53	935	0.174	163	0.2	4.757	A

2026 Base , AM

Data Errors and Warnings

No errors or warnings

Junction Network

Junctions

Junction	Name	Junction type	Use circulating lanes	Arm order	Junction Delay (s)	Junction LOS
1	untitled	Mini-roundabout		1, 2, 3	10.56	B

Junction Network Options

Driving side	Lighting	Road surface	In London
Left	Normal/unknown	Normal/unknown	

Traffic Demand

Demand Set Details

ID	Scenario name	Time Period name	Traffic profile type	Start time (HH:mm)	Finish time (HH:mm)	Time segment length (min)
D3	2026 Base	AM	ONE HOUR	08:00	09:30	15

Vehicle mix source	PCU Factor for a HV (PCU)
HV Percentages	2.00

Demand overview (Traffic)

Arm	Linked arm	Use O-D data	Average Demand (PCU/hr)	Scaling Factor (%)
1		✓	303	100.000
2		✓	220	100.000
3		✓	183	100.000

Demand overview (Pedestrians)

Arm	Average pedestrian flow (Ped/hr)
1	10.00
2	10.00
3	10.00

Origin-Destination Data

Demand (PCU/hr)

		To		
		1	2	3
From	1	0	98	205
	2	119	0	101
	3	118	65	0

Vehicle Mix

Heavy Vehicle Percentages

		To		
		1	2	3
From	1	0	3	3
	2	3	0	5
	3	6	2	0

Results

Results Summary for whole modelled period

Arm	Max RFC	Max Delay (s)	Max Queue (PCU)	Max LOS
1	0.51	11.61	1.1	B
2	0.46	13.29	0.9	B
3	0.23	5.53	0.3	A

Main Results for each time segment

08:00 - 08:15

Arm	Total Demand (PCU/hr)	Circulating flow (PCU/hr)	Pedestrian demand (Ped/hr)	Capacity (PCU/hr)	RFC	Throughput (PCU/hr)	End queue (PCU)	Delay (s)	Unsignalised level of service
1	228	49	7.53	667	0.342	226	0.5	8.367	A
2	166	153	7.53	578	0.286	164	0.4	9.001	A
3	138	89	7.53	912	0.151	137	0.2	4.855	A

08:15 - 08:30

Arm	Total Demand (PCU/hr)	Circulating flow (PCU/hr)	Pedestrian demand (Ped/hr)	Capacity (PCU/hr)	RFC	Throughput (PCU/hr)	End queue (PCU)	Delay (s)	Unsignalised level of service
1	272	58	8.99	661	0.412	272	0.7	9.503	A
2	198	184	8.99	555	0.356	197	0.6	10.424	B
3	165	107	8.99	899	0.183	164	0.2	5.119	A

08:30 - 08:45

Arm	Total Demand (PCU/hr)	Circulating flow (PCU/hr)	Pedestrian demand (Ped/hr)	Capacity (PCU/hr)	RFC	Throughput (PCU/hr)	End queue (PCU)	Delay (s)	Unsignalised level of service
1	334	71	11.01	653	0.511	332	1.1	11.515	B
2	242	225	11.01	524	0.462	241	0.9	13.155	B
3	201	130	11.01	882	0.228	201	0.3	5.523	A

08:45 - 09:00

Arm	Total Demand (PCU/hr)	Circulating flow (PCU/hr)	Pedestrian demand (Ped/hr)	Capacity (PCU/hr)	RFC	Throughput (PCU/hr)	End queue (PCU)	Delay (s)	Unsignalised level of service
1	334	72	11.01	653	0.511	334	1.1	11.611	B
2	242	226	11.01	523	0.463	242	0.9	13.293	B
3	201	131	11.01	882	0.228	201	0.3	5.531	A

09:00 - 09:15

Arm	Total Demand (PCU/hr)	Circulating flow (PCU/hr)	Pedestrian demand (Ped/hr)	Capacity (PCU/hr)	RFC	Throughput (PCU/hr)	End queue (PCU)	Delay (s)	Unsignalised level of service
1	272	59	8.99	661	0.412	274	0.7	9.607	A
2	198	185	8.99	554	0.357	199	0.6	10.562	B
3	165	108	8.99	899	0.183	165	0.2	5.132	A

09:15 - 09:30

Arm	Total Demand (PCU/hr)	Circulating flow (PCU/hr)	Pedestrian demand (Ped/hr)	Capacity (PCU/hr)	RFC	Throughput (PCU/hr)	End queue (PCU)	Delay (s)	Unsignalised level of service
1	228	49	7.53	667	0.342	229	0.5	8.482	A
2	166	155	7.53	577	0.287	166	0.4	9.126	A
3	138	90	7.53	911	0.151	138	0.2	4.870	A

2026 Base, PM

Data Errors and Warnings

No errors or warnings

Junction Network

Junctions

Junction	Name	Junction type	Use circulating lanes	Arm order	Junction Delay (s)	Junction LOS
1	untitled	Mini-roundabout		1, 2, 3	8.17	A

Junction Network Options

Driving side	Lighting	Road surface	In London
Left	Normal/unknown	Normal/unknown	

Traffic Demand

Demand Set Details

ID	Scenario name	Time Period name	Traffic profile type	Start time (HH:mm)	Finish time (HH:mm)	Time segment length (min)
D4	2026 Base	PM	ONE HOUR	17:00	18:30	15

Vehicle mix source	PCU Factor for a HV (PCU)
HV Percentages	2.00

Demand overview (Traffic)

Arm	Linked arm	Use O-D data	Average Demand (PCU/hr)	Scaling Factor (%)
1		✓	228	100.000
2		✓	168	100.000
3		✓	229	100.000

Demand overview (Pedestrians)

Arm	Average pedestrian flow (Ped/hr)
1	10.00
2	10.00
3	10.00

Origin-Destination Data

Demand (PCU/hr)

		To		
		1	2	3
From	1	0	91	137
	2	74	0	94
	3	111	118	0

Vehicle Mix

Heavy Vehicle Percentages

		To		
		1	2	3
From	1	0	0	0
	2	2	0	5
	3	1	3	0

Results

Results Summary for whole modelled period

Arm	Max RFC	Max Delay (s)	Max Queue (PCU)	Max LOS
1	0.41	9.81	0.7	A
2	0.32	9.52	0.5	A
3	0.28	5.54	0.4	A

Main Results for each time segment

17:00 - 17:15

Arm	Total Demand (PCU/hr)	Circulating flow (PCU/hr)	Pedestrian demand (Ped/hr)	Capacity (PCU/hr)	RFC	Throughput (PCU/hr)	End queue (PCU)	Delay (s)	Unsignalised level of service
1	172	88	7.53	644	0.267	170	0.4	7.581	A
2	126	102	7.53	613	0.206	125	0.3	7.628	A
3	172	55	7.53	933	0.185	171	0.2	4.814	A

17:15 - 17:30

Arm	Total Demand (PCU/hr)	Circulating flow (PCU/hr)	Pedestrian demand (Ped/hr)	Capacity (PCU/hr)	RFC	Throughput (PCU/hr)	End queue (PCU)	Delay (s)	Unsignalised level of service
1	205	106	8.99	633	0.324	205	0.5	8.395	A
2	151	123	8.99	598	0.252	151	0.3	8.333	A
3	206	66	8.99	926	0.222	206	0.3	5.098	A

17:30 - 17:45

Arm	Total Demand (PCU/hr)	Circulating flow (PCU/hr)	Pedestrian demand (Ped/hr)	Capacity (PCU/hr)	RFC	Throughput (PCU/hr)	End queue (PCU)	Delay (s)	Unsignalised level of service
1	251	130	11.01	618	0.406	250	0.7	9.770	A
2	185	150	11.01	577	0.320	184	0.5	9.484	A
3	252	81	11.01	915	0.275	252	0.4	5.532	A

17:45 - 18:00

Arm	Total Demand (PCU/hr)	Circulating flow (PCU/hr)	Pedestrian demand (Ped/hr)	Capacity (PCU/hr)	RFC	Throughput (PCU/hr)	End queue (PCU)	Delay (s)	Unsignalised level of service
1	251	130	11.01	618	0.406	251	0.7	9.814	A
2	185	151	11.01	577	0.321	185	0.5	9.518	A
3	252	81	11.01	915	0.275	252	0.4	5.538	A

18:00 - 18:15

Arm	Total Demand (PCU/hr)	Circulating flow (PCU/hr)	Pedestrian demand (Ped/hr)	Capacity (PCU/hr)	RFC	Throughput (PCU/hr)	End queue (PCU)	Delay (s)	Unsignalised level of service
1	205	106	8.99	633	0.324	206	0.5	8.449	A
2	151	124	8.99	598	0.253	152	0.4	8.376	A
3	206	67	8.99	926	0.222	206	0.3	5.109	A

18:15 - 18:30

Arm	Total Demand (PCU/hr)	Circulating flow (PCU/hr)	Pedestrian demand (Ped/hr)	Capacity (PCU/hr)	RFC	Throughput (PCU/hr)	End queue (PCU)	Delay (s)	Unsignalised level of service
1	172	89	7.53	643	0.267	172	0.4	7.647	A
2	126	103	7.53	613	0.206	127	0.3	7.687	A
3	172	56	7.53	933	0.185	173	0.2	4.833	A

2026 Base + Construction, AM

Data Errors and Warnings

No errors or warnings

Junction Network

Junctions

Junction	Name	Junction type	Use circulating lanes	Arm order	Junction Delay (s)	Junction LOS
1	untitled	Mini-roundabout		1, 2, 3	11.03	B

Junction Network Options

Driving side	Lighting	Road surface	In London
Left	Normal/unknown	Normal/unknown	

Traffic Demand

Demand Set Details

ID	Scenario name	Time Period name	Traffic profile type	Start time (HH:mm)	Finish time (HH:mm)	Time segment length (min)
D11	2026 Base + Construction	AM	ONE HOUR	08:00	09:30	15

Vehicle mix source	PCU Factor for a HV (PCU)
HV Percentages	2.00

Demand overview (Traffic)

Arm	Linked arm	Use O-D data	Average Demand (PCU/hr)	Scaling Factor (%)
1		✓	315	100.000
2		✓	220	100.000
3		✓	209	100.000

Demand overview (Pedestrians)

Arm	Average pedestrian flow (Ped/hr)
1	10.00
2	10.00
3	10.00

Origin-Destination Data

Demand (PCU/hr)

		To		
		1	2	3
From	1	0	98	217
	2	119	0	101
	3	144	65	0

Vehicle Mix

Heavy Vehicle Percentages

	To			
	1	2	3	
From	1	0	3	8
	2	3	0	5
	3	11	2	0

Results

Results Summary for whole modelled period

Arm	Max RFC	Max Delay (s)	Max Queue (PCU)	Max LOS
1	0.53	12.51	1.2	B
2	0.47	13.70	0.9	B
3	0.26	5.98	0.4	A

Main Results for each time segment

08:00 - 08:15

Arm	Total Demand (PCU/hr)	Circulating flow (PCU/hr)	Pedestrian demand (Ped/hr)	Capacity (PCU/hr)	RFC	Throughput (PCU/hr)	End queue (PCU)	Delay (s)	Unsignalised level of service
1	237	49	7.53	667	0.356	235	0.6	8.816	A
2	166	162	7.53	573	0.289	164	0.4	9.113	A
3	157	89	7.53	911	0.173	156	0.2	5.147	A

08:15 - 08:30

Arm	Total Demand (PCU/hr)	Circulating flow (PCU/hr)	Pedestrian demand (Ped/hr)	Capacity (PCU/hr)	RFC	Throughput (PCU/hr)	End queue (PCU)	Delay (s)	Unsignalised level of service
1	283	58	8.99	661	0.428	282	0.8	10.091	B
2	198	195	8.99	549	0.360	197	0.6	10.623	B
3	188	107	8.99	898	0.209	188	0.3	5.473	A

08:30 - 08:45

Arm	Total Demand (PCU/hr)	Circulating flow (PCU/hr)	Pedestrian demand (Ped/hr)	Capacity (PCU/hr)	RFC	Throughput (PCU/hr)	End queue (PCU)	Delay (s)	Unsignalised level of service
1	347	71	11.01	653	0.531	345	1.2	12.389	B
2	242	238	11.01	516	0.470	241	0.9	13.541	B
3	230	130	11.01	880	0.261	230	0.4	5.973	A

08:45 - 09:00

Arm	Total Demand (PCU/hr)	Circulating flow (PCU/hr)	Pedestrian demand (Ped/hr)	Capacity (PCU/hr)	RFC	Throughput (PCU/hr)	End queue (PCU)	Delay (s)	Unsignalised level of service
1	347	72	11.01	653	0.531	347	1.2	12.509	B
2	242	239	11.01	515	0.470	242	0.9	13.701	B
3	230	131	11.01	880	0.262	230	0.4	5.984	A

09:00 - 09:15

Arm	Total Demand (PCU/hr)	Circulating flow (PCU/hr)	Pedestrian demand (Ped/hr)	Capacity (PCU/hr)	RFC	Throughput (PCU/hr)	End queue (PCU)	Delay (s)	Unsignalised level of service
1	283	59	8.99	661	0.428	285	0.8	10.221	B
2	198	196	8.99	547	0.361	199	0.6	10.775	B
3	188	108	8.99	897	0.209	188	0.3	5.488	A

09:15 - 09:30

Arm	Total Demand (PCU/hr)	Circulating flow (PCU/hr)	Pedestrian demand (Ped/hr)	Capacity (PCU/hr)	RFC	Throughput (PCU/hr)	End queue (PCU)	Delay (s)	Unsignalised level of service
1	237	49	7.53	667	0.356	238	0.6	8.951	A
2	166	164	7.53	571	0.290	166	0.4	9.253	A
3	157	90	7.53	910	0.173	158	0.2	5.169	A

2026 Base + Construction, PM

Data Errors and Warnings

No errors or warnings

Junction Network

Junctions

Junction	Name	Junction type	Use circulating lanes	Arm order	Junction Delay (s)	Junction LOS
1	untitled	Mini-roundabout		1, 2, 3	8.92	A

Junction Network Options

Driving side	Lighting	Road surface	In London
Left	Normal/unknown	Normal/unknown	

Traffic Demand

Demand Set Details

ID	Scenario name	Time Period name	Traffic profile type	Start time (HH:mm)	Finish time (HH:mm)	Time segment length (min)
D12	2026 Base + Construction	PM	ONE HOUR	17:00	18:30	15

Vehicle mix source	PCU Factor for a HV (PCU)
HV Percentages	2.00

Demand overview (Traffic)

Arm	Linked arm	Use O-D data	Average Demand (PCU/hr)	Scaling Factor (%)
1		✓	254	100.000
2		✓	168	100.000
3		✓	241	100.000

Demand overview (Pedestrians)

Arm	Average pedestrian flow (Ped/hr)
1	10.00
2	10.00
3	10.00

Origin-Destination Data

Demand (PCU/hr)

From	To		
	1	2	3
1	0	91	163
2	74	0	94
3	123	118	0

Vehicle Mix

Heavy Vehicle Percentages

From	To		
	1	2	3
1	0	0	7
2	2	0	5
3	8	3	0

Results

Results Summary for whole modelled period

Arm	Max RFC	Max Delay (s)	Max Queue (PCU)	Max LOS
1	0.45	11.11	0.9	B
2	0.33	10.01	0.5	B
3	0.29	5.85	0.4	A

Main Results for each time segment

17:00 - 17:15

Arm	Total Demand (PCU/hr)	Circulating flow (PCU/hr)	Pedestrian demand (Ped/hr)	Capacity (PCU/hr)	RFC	Throughput (PCU/hr)	End queue (PCU)	Delay (s)	Unsignalised level of service
1	191	88	7.53	644	0.297	189	0.4	8.243	A
2	126	122	7.53	601	0.210	125	0.3	7.830	A
3	181	55	7.53	933	0.194	180	0.3	5.039	A

17:15 - 17:30

Arm	Total Demand (PCU/hr)	Circulating flow (PCU/hr)	Pedestrian demand (Ped/hr)	Capacity (PCU/hr)	RFC	Throughput (PCU/hr)	End queue (PCU)	Delay (s)	Unsignalised level of service
1	228	106	8.99	633	0.361	228	0.6	9.262	A
2	151	146	8.99	583	0.259	151	0.4	8.627	A
3	217	66	8.99	925	0.234	216	0.3	5.356	A

17:30 - 17:45

Arm	Total Demand (PCU/hr)	Circulating flow (PCU/hr)	Pedestrian demand (Ped/hr)	Capacity (PCU/hr)	RFC	Throughput (PCU/hr)	End queue (PCU)	Delay (s)	Unsignalised level of service
-----	-----------------------	---------------------------	----------------------------	-------------------	-----	---------------------	-----------------	-----------	-------------------------------

1	280	130	11.01	618	0.453	279	0.8	11.040	B
2	185	179	11.01	558	0.331	184	0.5	9.962	A
3	265	81	11.01	915	0.290	265	0.4	5.840	A

17:45 - 18:00

Arm	Total Demand (PCU/hr)	Circulating flow (PCU/hr)	Pedestrian demand (Ped/hr)	Capacity (PCU/hr)	RFC	Throughput (PCU/hr)	End queue (PCU)	Delay (s)	Unsignalised level of service
1	280	130	11.01	618	0.453	280	0.9	11.109	B
2	185	179	11.01	558	0.332	185	0.5	10.006	B
3	265	81	11.01	915	0.290	265	0.4	5.849	A

18:00 - 18:15

Arm	Total Demand (PCU/hr)	Circulating flow (PCU/hr)	Pedestrian demand (Ped/hr)	Capacity (PCU/hr)	RFC	Throughput (PCU/hr)	End queue (PCU)	Delay (s)	Unsignalised level of service
1	228	106	8.99	633	0.361	229	0.6	9.342	A
2	151	147	8.99	582	0.259	152	0.4	8.680	A
3	217	67	8.99	925	0.234	217	0.3	5.366	A

18:15 - 18:30

Arm	Total Demand (PCU/hr)	Circulating flow (PCU/hr)	Pedestrian demand (Ped/hr)	Capacity (PCU/hr)	RFC	Throughput (PCU/hr)	End queue (PCU)	Delay (s)	Unsignalised level of service
1	191	89	7.53	643	0.297	192	0.4	8.336	A
2	126	123	7.53	600	0.211	127	0.3	7.897	A
3	181	56	7.53	933	0.195	182	0.3	5.060	A

Get in touch

You can contact us by:



Emailing at info@cwwtpr.com



Calling our Freephone information line on **0808 196 1661**



Writing to us at **Freepost: CWWTPR**

You can view all our DCO application documents and updates on the application on The Planning Inspectorate website:

<https://infrastructure.planninginspectorate.gov.uk/projects/eastern/cambridge-waste-water-treatment-plant-relocation/>